

KELLOGG

SWITCHBOARD AND SUPPLY COMPANY
6650 S. CICERO AVENUE — CHICAGO

KELLOGG Switchboards, Telephones & Supplies

GENERAL CATALOG NO. 10

1941

PDF PART 2, Section 5 Sw Bd Parts, Section 6 Telephones & Parts, Section 7 Telephone & SB Cords

See index for contents

A general telephone, switchboard and line supplies catalog distributed in 1941, the last catalog before WWII, it would be 8 years before a replacement would be printed in the number 11, 1949. This catalog was produced in looseleaf form and this copy had several inserts from 1946 and 1947 (the 1000 series sets) however it is presented in this PDF in its 1941 published format. A companion catalog (number 100) was also produced for the magneto orinated manual central office companies, and is available in the PDF format from the Kellogg website.

Adobe Document Scanned and Produced by Mike Neale, Member of
Antique Telephone Collectors Association US
Telephone Collectors International US

www.kelloggtelephone.com

www.federaltelephoneradio.com

www.redbartelephone.com

www.selectophone.com

www.strombergcarlsontelephone.com

Adobe Document Contents Copyright 2008, Mike Neale, Midland, Texas, USA
Optimized for viewing with Adobe Reader 7.0 or better and web loading.



www.telephonecollectors.org



www.atcaonline.com



KELLOGG



**SWITCHBOARDS
TELEPHONES
SUPPLIES**



**GENERAL CATALOG
No 10**

C H I C A G O U . S . A .

The
TELEPHONE INDUSTRY'S
most complete
useful, and
convenient
GENERAL CATALOG



This Kellogg General Catalog, comprising eight different sections and a General Index, contains everything required for the economical operation and maintenance of telephone systems. It is so complete and is arranged in such a manner as to make it the most convenient and useful general telephone reference book available.

All types of Kellogg central office equipment and sub-station apparatus, repair parts, outside plant material, construction items, tools, etc., are contained here UNDER ONE COVER.

Complete descriptions, giving the kind of information you want, with clearly defined illustrations used throughout, mean that you can order from this book . . . without doubt or question . . . with complete assurance that any item selected will do the job for which it is designed.

Every item in this catalog is listed and cross-indexed alphabetically in the General Index Section. This reference directs you to the particular section and page number of each of the thousands of items contained in the entire catalog . . . quickly and easily.



KELLOGG
SWITCHBOARD AND SUPPLY COMPANY
6650 S. CICERO AVENUE — CHICAGO

General Index

GENERAL INDEX

B (continued)

	Sec. No.	Page No.
Brackets (continued)		
Transposition	8	52-53
Transposition Break		
Iron	8	53
U-Bolt Type	8	52
Wall	8	53
Western Union	8	52
Wood	8	8
Bracket Clips	8	8
Brackets, Condenser		
Mounting	6	39
Bracket Reinforcing		
Straps	8	8
Braid Strippers	8	101
Breast Drills	8	95
Breastplate Sets	5	37
Breastplate Transmitter		
Cords	7	12
Bridging Connectors	8	38
Bridges, Fault Location	8	90
Bridle Rings, Toggle	8	80
Bridges, Wheatstone	8	90-91
Bridle Wire	8	138
Broad Hatchet	8	96
Bronze Drop Wire	8	136-137
Buckets, Canvas	8	120
Buffalo Grips	8	121
Burner, Weed	8	113
Bus Bars	5	2
Buttons, Push	8	21
Butt Plates	8	58
Butt Treatment Pole	8	150
Buzzers	8	21-83

C

Cabinets, Test	1	19-20
Cabinets, Steel	8	45
Cable		
Armored	8	28-32
Bandage	8	74
Bands	8	79
Benders	8	70
Cars	8	107
Clamps	8	38
Clamps, Combination	8	80
Compound	8	74
Cutters	8	107
Duct Shields	8	71
Extension Arms	8	64
Feeder and		
Straightener	8	70-71
Grips	8	133
Guards	8	60
Guides	8	70-71
Hangers	8	78-79
Jacks	8	69
Jute and Lead		
Covered	8	32
Lead Sheathed,		
Underground	8	140
Moulding	8	9
Paint	8	76
Paper and Lead		
Covered	8	28-32
Pasters	8	73
Power Cable	7	18
Pulling Compound	8	74
Rack Arms	8	69
Rack Insulators	8	69
Racks	8	69
Reel Jacks	8	123
Reel Wheels	8	70

C (continued)

	Sec. No.	Page No.
Cable (continued)		
Reinforcing Links	8	54
Repair Kits	8	75
Repair Sleeves	8	75
Rings	8	78-79
Ring Saddles	8	78
Rollers, Matlock	8	70
Shields	8	71
Skids and Sheaves	8	71
Sleeves	8	72
Sleeves, Repair	8	75
Spinning Machines	8	92
Aplicers Tents	8	107
Straps	8	60
Stripper Knives	8	108
Supports	8	79
Suspension Clamps	8	55
Switchboard Cable	7	17
Telephone	8	28-32
Terminals	8	16-18
Testers	8	89
Wrapping Cloth	8	74
Cable Wire	7	18
Calculagraphs	8	36
Calculagraph Pedestals	8	36
Calculagraph Ribbons	8	36
Cam Keys	8	25-35
Candles	8	73
Cant Hooks	8	131
Caps, Lamp	5	21-22
Capstan Pulley Blocks	8	124
Capsule Type Receivers	6	45
Capsule Type		
Transmitters	6	46
Car Bits	8	94
Carbolineum	8	76
Carbon Blocks	8	15
Cars, Cable	8	107
Carbons, Protector	8	15
Carbon Tetrachloride	8	33
Carbosota	8	76
Carriage Bolts	8	50
Carrying or Lug Hooks	8	131
Cases, Plier	8	120
Cases, Tool	8	120
Cedar Poles	8	149-153
Central Office		
Protectors	4	4-8
Chain Tapes	8	102
Chairs		
Linemen's Safety	8	107
Operator's	8	44
Safety	8	107
Changers, Pole	4	16
Channel Pole Brackets	8	59
Charging Equipment	4	13-15
Chicago Grips	8	121
Chisels	8	94
Circulators, Air	8	35
Circuit, Triad	6	7
Clamps		
Cable	8	38
Cable Suspension	8	55
Combination Cable	8	80
Crossover	8	62
Drop Wire	8	49
Grade	8	54
Ground	8	62-63
Guy	8	55
Neck Band	8	37
Pole Stubbing	8	65

C (continued)

	Sec. No.	Page No.
Clamps (continued)		
Span	8	48
Wire Splicing	8	100
Clamps, Escutcheon	5	32
Clay Conduit	8	40-41
Cleaners		
Carbon Tetrachloride	8	33-35
Supershyne	8	33
Switchboard Jack	8	33
Vacuum	8	34
Clear Out Drops	5	11-14
Clear Out Drop		
Mountings	5	12
Cleats, Fibre	8	77
Clevis Strain Insulator	8	59
Clevis, Upset Type	8	59
Climber Gaff Guards	8	117
Climbers, Linemen's	8	117
Climber Pads	8	117
Climber Straps	8	117
Clips		
Drop Wire	8	49
Fahnestock	8	39
Guy Wire	8	61
Neck Band	8	37
Test	8	39
Wire Rope	8	54-61
Wood Bracket	8	8
Clips, Jack Mounting	5	23
Clocks	8	37
Cloth, Cable Wrapping	8	74
Cloths, Wiping	8	109
Coils		
A. C. Relays Coils	5	41
Battery Feed	5	6
Clear Out Drop Coils	5	11
Drainage	5	4
Heat	5	2
and	8	14
Induction (Swbd.)	5	2-3
Induction (Tel.)	6	39
Mountings	8	15
Operator's Feed	5	3
Phantom	5	4
Protectors	8	15
Relay	5	41-45
Repeating	5	4-5
Resistance	5	7
Retardation	5	5
Trip Relay Coils	5	42
Cold Chisels	8	94
Collapsible Tool Bag	8	120
Combination Cable		
Clamps	8	80
Combination		
Masterphones	6	10-28
Combination Test Jack		
& Switch	5	45
Combination Wrenches	8	101
Combined Drops and		
Jacks	5	9-10
Combined Drop and		
Jack Mountings	5	
Combined Ringer,		
Drop and Jack	5	12
Combined Ringer, Drop		
& Jack Mounting	5	
Common Battery Desk		
Set Boxes	6	23-24

GENERAL INDEX

C (continued)

	Sec. No.	Page No.
Common Battery		
Ringers	6	44
Common Battery		
Telephones	6	10-26
Commutator		
Resurfacers	8	104
Compact Type Wall		
Telephones	6	29
Compass Saws	8	103
Composite Wall		
Telephones	6	31
Composition Fuses	8	14
Compound		
Cable	8	74-76
Cable Pulling	8	74
Kettle	8	108-116
Pothead	8	76
Condensers, Noise		
Killer	4	12
Condensers (Swbd.)	5	7-8
Condensers (Tel.)	6	33
Condenser Mounting		
Brackets	6	39
Conduit	8	40-43
Clay	8	40-41
Fibre	8	42-43
Tel-Tile	8	43
Wood	8	43
Conduit Bends	8	41-42
Conduit Rods	8	71
Conduit Straps	8	71
Conduit Wire	8	139
Cone Anchors	8	4
Cones, Ground	8	63
Connecting Blocks	8	38-39
Connecting Poles	8	91
Connecting Racks	6	39
Connector Blocks	6	36
Connectors		
Bridging	8	38
Conduit	8	41
Sleeve	8	38
Strand	8	84-86
Test	8	54
Conversion Kits (Tel.)	6	39
Converters, Ringing	4	19-20
Cook Central Office		
Protection Equipment	4	2-8
Cook Sub-Station		
Protectors	8	15-20
Coppers, Soldering	8	111
Copper Oxide Battery		
Chargers	4	13-14
Copperweld		
Cable Rings	8	78
Ground Rods	8	62
Ground Wire Clamps	8	62
Staples	8	9
Copper Wire, Bare	8	140
Copper Wire, Insulated	8	140
Cords, Telephone		
and Switchboard	7	1-20
Handset	7	6-8
Retractable	8	39
and	7	20
Cord Cabinets	8	45
Cord Drawings	7	6-15
Cord Hooks	7	16
Cordless Switchboards	3	5-6

C (continued)

	Sec. No.	Page No.
Cord Tips	7	16
Cord Weights	7	16
Cords, Listed by Types	7	4
Corner Bit Braces	8	95
Corner Brackets	8	48
Corner Pins	8	8
Cotton Sleeves	8	73
Cotton Sleeving	8	73
Cotton Splicing Tape	8	74
Counters	8	37
Hand	8	37
Set Back	8	37
Straight	8	37
Covers, Manhole	8	69
Cover Plate	6	37
Coupling Rods	8	71
Creosote Oil	8	76
Crosby Clips	8	54
Cross Arms		
Bolts	8	50
Braces	8	51
Pins	8	8
Cross Arms, Fir and		
Pine—Specifications	8	6-7
Cross Arm and Pole Bits	8	94
Cross-Connecting		
Equipment	4	2-8
Cross Cut Saws	8	103
Cross Over Brackets	8	53
Cross Over Clamps	8	55
Crow Bars	8	128
Current Flow Test Sets	8	90
Curved Washers	8	51
Customer Information	1	2
Cutters		
Bolts	8	101
Cable	8	107
Porcelain Tube	8	101
Wire	8	101
Cylinder Bellows	8	35

D

Danger Flags	8	111
Danger Flares	8	111
Danger Signs	8	111
Dating Nails	8	77
Davidson Cable Hangers	8	79
Dead End Messenger	8	58
Dead End Shackles	8	59
Dead End Sleeves	8	85
Deadman	8	130
Desiccant, Drierite	8	75
Designation Strips	5	24
Desk Set Boxes		
Bakelite	6	23
Common Battery	6	23-24
Magneto	6	27-28
Steel	6	24
Wood	6	27-28
Desk Stands		
Common Battery	6	24
Magneto	6	28
Desk Stand Cords	7	8-10
Desk Stand		
Transmitter Cords	7	10
Desk Type Masterphones		
Common Battery	6	10-22
Magneto	6	10-28

D (continued)

	Sec. No.	Page No.
Detecto-Meter	8	87
Dial Blanks	6	37
Dial Switchboards	2	2-8
Dial Type Masterphones	6	10-21
Dial Type Telephones	6	10-25
Dielectrics	8	15
Digging Bars	8	128-129
Digging Tools	8	126-129
Direct Reading Test Sets	8	87
Discharge Blocks	8	15
Distributing Brackets	8	49
Distributing Frames	4	2-7
Distributing Strips	8	19
Docking Saws	8	103
Doe's Plug Burnishing		
Paste	8	33
Double Arming Bolts	8	50
Dowel Pins	8	41
Drainage Coils	5	
Drawings, Cord	7	6-15
Draw Knives	8	96
Dressers, Hardwood	8	108
Drierite Desiccant	8	75
Drift Plugs	8	108
Drill Braces	8	95
Drill Holder	8	93
Drill Points	8	94-97
Drills	8	93-95
Drive and Twist Anchors	8	5
Drive Hooks	8	49
Drive Rings	8	80
Drivers, Screw	8	97
Drops and Jacks,		
Combined	5	9-10
Drops, Clear-Out	5	11
Drop Mountings	5	11-14
Drop and Jack		
Mountings	5	11-14
Drop Wire	8	136-138
Drop Wire		
Brackets	8	48
Clamps	8	49
Clips	8	49
Grips	8	49
Hooks	8	49
Dry Cells	8	20
Dryvin Masonry Hooks	8	49
Duct Shields, Cable	8	71
Duct Wire	8	139
Duplex Pins	8	8
Dynamometers	8	124
Dynamotor, Ringing	4	18

E

Edison Primary		
Batteries	8	21
Electric Cleaners	8	34
Electricians Knives	8	108
Electricians Scissors	8	108
Electric Soldering Irons	8	110
Emergency First Aid		
Equipment	8	47
Equipment, Manhole	8	69-71
Equipment, Testing	8	87-91
Escutcheons for Cam		
Keys	5	27-28
Escutcheon Clamps	5	32
Escutcheons for Keys	5	30-32

General Index

GENERAL INDEX

E (continued)

	Sec. No.	Page No.
Exide Charge Control	4	15
Exide Storage Batteries	4	9-10
Expanding Anchors	8	4
Expansive Bits	8	94
Expansion Shields	8	93
Extension Arms, Tel.	6	30
Extension Arms, Cable	8	64
Extension Bells, Magnet	6	33
Extensions, Bit	8	94
Extension Fixture Braces	8	51
Extension Ladders	8	68
Extension Shafts	5	47
Extension Straps	8	118
Extinguishers, Fire	8	46
Eye Bolts	8	56
Eye Nuts	8	94

F

Fahnestock Clips	8	39
Fans, Electric	8	35
Fan Guards	8	35
Fansteel Balkite Taper Rectifiers	4	14
Fasteners, Cord	7	16
Fault Location Bridges	8	90-91
Featherweight Receivers	5	37
Feed Coils, Operators	5	3-6
Feeders, Cable	8	71
Felt Paper, Tarred	8	76
Fibre Cleats	8	77
Conduit	8	42-43
Conduit Fittings	8	43
Fuses	8	14
Test Boards	8	108
Filters, Pole Changer	4	17
Fir Cross Arms	8	6-7
Fire Extinguishers	8	46
Fire Guns	8	113
Fire Pots	8	115-116
First Aid Equipment	8	47
Fish Tape	8	92
Fish Tape Pullers	8	92
Fish Tape Reels	8	92
Fish Wire	8	92
Flags, Danger	8	111
Flameproof Jumper Wire	7	19
Flares, Highway	8	139
Flat Cross Arm Braces	8	111
Flexible, Insulated Stranded Wire	7	18
Flexible Mandrels	8	70
Flush Mounting Plugs and Jacks	6	35
Foot Switch	6	30
Forks, Raising	8	130
Forester Pruners	8	104
Fork Bolts, Insulated	8	59
Four Party Keys	5	29-36
Frames, Hack Saw	8	103
Frames, Distributing	4	2-7
Frames, Manhole	8	69

F (continued)

	Sec. No.	Page No.
Frequency Meters	4	17
Friction Tape	8	74
Front Mounting Wall Masterphones	6	19-27
Fronts, Transmitter	6	46
Furnaces, Gasoline	8	115-116
Furnaces, Kerosene	8	115-116
Fuses	8	14
Fuse Posts	5	2
Fuse Wire	8	14

G

Gaff Guards	8	117
Gains, Pole	8	65
Gasoline Furnaces	8	115-116
Gas Tanks, Prest-O-Lite	8	113
Gauges, Wire	8	106
G. E. Copper Oxide Battery Chargers	4	13-14
Generators (Swbd.)	5	47
Generators (Tel.)	6	40
Generator Boxes	6	30
Generator Extension Shafts	5	47
Generators, Motor	4	141
Generators, Tone	8	19
Generator Wire	7	66
Glass Insulators	8	102
Gloves, Rubber	8	42-44
Gongs, Ringer	6	10-11
Gould Storage Batteries	4	54
Grade Clamps	8	21
Gravity Type Batteries	8	133
Grips Cable	8	49
Drop Wire	8	121
Wire	8	63
Ground Cones	8	62
Ground Rods	8	62-63
Ground Rod Clamps	8	62-63
Ground Wire Clamps	8	9
Ground Wire Moulding	8	77
Ground Wire Staples	8	7
Guard Arms	8	58
Guard Arm Braces	8	58
Guard Arm Hooks	8	130
Guarded Pike Poles	8	35
Guards Fan	8	117
Gaff	8	60
Guy	8	58
Hub	8	69
Manhole	8	129
Pike Pole	8	9
Tree	8	60
U Cable	8	70-71
Guides, Cable	8	55
Guy Clamps	8	54
Clips	8	60
Guards	8	57
Hooks	8	57
Hook Strain Plates	8	57
Plates	8	4
Rods	8	58
Shims	8	125
Stretchers	8	

G (continued)

	Sec. No.	Page No.
Guy (continued) Thimbles	8	57
Wire Protectors	8	60
Guy Wire	8	134
Guy Wire Clip Tools	8	61

H

Hack Saws	8	103
Hack Saw Blades	8	103
Hack Saw Frames	8	103
Hammers	8	96
Hammer Drills	8	93
Hammer Drive Anchors	8	80
Hand Counters	8	37
Hand Drills	8	95
Handsets	6	23-24
Handsets, Metal	6	34
Handset Cords	7	6-8
Handset Telephones Common Battery	6	10-26
Magnet	6	10-29
Handles, Pike Pole	8	130
Handles, Solder Copper	8	111
Hand Receivers	6	45
Hangers, Cable	8	78-79
Hangers, Messenger	8	55
Hardware, Pole Line	8	48-65
Hardware Dressers	8	108
Harmonic Pole Changers	4	42-44
Harmonic Ringers	6	118
Harness, Safety	8	5
Harpoon Anchors	8	96
Hatchets	8	121
Havens Grips	8	38
Head Bands	5	45
and 6		45
Head Set Cabinets	8	14
Heat Coils	8	2
and 5		30-31
Heavy Duty Telephones	6	136
Hi-Conducto Bronze Drop Wire	8	53
Highway Cross-Over Brackets	8	111
Highway Flares	8	124-125
Hoists	8	124
Hoists, Safety Pull	8	94
Holdings, Drill	8	49-53
Holdings, Wire	8	84
Holsters, Tool	8	59
Hook Bolts, Insulator	8	131
Hooks Cant	8	49
Drive	8	49
Drop Wire	8	49
Dryvin Masonry	8	49
Guard Arm	8	57
Guy	8	57
Jay	8	131
Lug or Carrying	8	69
Manhole Cover	8	49
Screw	8	108
Shave	8	41
Hookswitches	6	48
House Brackets	8	120
Housings, Coil	8	

GENERAL INDEX

H (continued)

	Sec. No.	Page No.
Howe's Wire Tools	8	121
Howlers	8	82
	and 6	31
Hub Guards	8	58
I		
Ignitor Batteries	8	20
Indicator Pins	5	24
Induction Coils (Swbd.)	5	2
Induction Coils (Tel.)	6	39
Industrial Signals	8	82-83
Information and Chief Operator's Equip.	1	20
Information, Customer	6	2
Insulated Fork Bolts	8	59
Insulated Nails and Staples	8	77
Insulated Screw Eyes	8	67
Insulated Telephones	6	30-31
Insulating Tape	8	74
Insulating Transformer	5	4
Insulators, Cable Racks	8	69
Insulators, Glass	8	66
Insulator Hook Bolts	8	58
Insulator Pins	8	8
Insulators, Porcelain	8	66
Interior Wire	8	138
Interrupters	4	20
Interrupter Switching Circuits	4	21
Iron Line Wire	8	135
Irons, Pulling-In	8	71
Irons, Soldering	8	110
Iron Wire, Weatherproof	8	139

J

Jack Cleaners, Switchboard	8	33
Jacks and Drops, Combined	5	9-10
Jacks, Lamps	5	22-23
Jack Mountings	5	17
Jack Mounting Pins, Lugs and Clips	5	23
Jacks, Operator's	5	20
Jacks, Pipe Pushing	8	123
Jacks, Pole Pulling	8	123
Jacks, Spring	5	15-17
Jacks, Wall Outlet	6	35
Jay Hooks	8	57
Jenney Supports	8	130
Joint Tape	8	41
Jumper Wire, Flameproof	7	19
	and 8	139
Jumper Wire Reels	8	132
Junction Boxes	8	19
Junior Test Cabinets	1	19

K

Kellogg Cords Listed by Types	7	4
Kellogg Equivalents of Other Cords	7	5

K (continued)

	Sec. No.	Page No.
Kellogg Coiled Kords	8	20
	and 8	
Kellogg Relaymatic Switchboards	2	2-7
Kellogg Special Solder	8	72
Kettle, Compound	8	108-116
Key Blanks	5	27
Key Boxes	6	35
Keys, Cam	5	25-35
Key Escutcheons	5	27-35
Key Escutcheon Clamps	5	32
Keys, Four Party	5	29-36
Keys, Order Wire	5	31-32
Keys, Push Button	5	31-32
Keys, Two Party	5	30-31
Kits		
Cable	8	75
First Aid	8	47
Tool	8	120
Kits, Conversion	6	37
Kits, Tool	5	19
Knives		
Cable Stripper	8	108
Draw	8	96
Electrician's	8	108
Sheath Splitting	8	108
Knife Switches	8	86
Knob Adapters	8	49
Knobs, Porcelain	8	67
Knob Racks	8	49
Koiled Kords	8	33

L

Ladle, Pouring	8	109
Ladders, All Types	8	68-69
Lag Screws	8	50
Lag Screw Expansion Shields	8	93
Lag Screw Wrenches	8	101
Lacing Twine	7	17
Lamp Caps	5	21-22
Lamp Hole Blanks	5	19
Lamp Jacks	5	22-23
Lamps, Mazda	5	21
Lamps, Switchboard	5	21
Lashing Wire	8	73
Lead Fuse Wire	8	14
Lead Sleeve	8	72
Leeds & Northup Testing Equipment	8	91
Letters and Numbers, Pole Marking	8	86
Lever, Switch Hook	6	41
Lift Plates	8	56
Lightweight Portable Telephones	6	32
Line Terminal Blocks	4	6-8
Lineman's Belts	8	119
Climbers	8	117
Hammers	8	96
Hatchets	8	96
Rubber Gloves	8	102
Safety Chairs	8	107
Straps, Safety	8	118
Tool Bags	8	120
Tool Belts	8	119
Wrenches	8	101
Lineman's Test Sets	6	32

L (continued)

	Sec. No.	Page No.
Links, Cable		
Reinforcing	8	54
Liquid, Soldering	8	72-73
Load Binders	8	124
Lockers	8	45
Locust Pins	8	8
Lorain Tone Generators	4	20-21
Loudringing Bells	6	33
Lug Hooks	8	131
Lugs, Jack Mounting	5	23
Lungen Bells, Buzzers	8	21

M

Machine Bolts	8	50
Magneto Desk Stands	6	28
Magneto Desk Set Boxes	6	27-28
Magneto Extension Bells	6	33
Magneto, Masterphones	6	10-29
Magneto Non-Adjustable Ringers	6	43
Magneto Ringing Sets	4	18
Magneto Switchboards, Masterbuilt	1	3-7
Magneto Switchboards, Wall Type	1	8-9
Magneto Telephones	6	10-33
Main Distributing Frames	4	2-7
Major Type Test Cabinets	1	20
Manhole Equipment	8	69-71
Cover Hooks	8	69
Covers	8	69
Frames	8	69
Guard Rails	8	69
Ladders	8	69
Sheave	8	71
Signs	8	111
Steps	8	69
Mandrels		
Flexible	8	70
Laying	8	70
Test	8	70
Manila Rope	8	74
Manual Type Telephones	6	10-33
Markers, Premax Pole	8	86
Marline Cable Hangers	8	78
Marline Twine	8	74
Masonry Hooks, Dryvin	8	49
Masterbuilt Cordless, PBX Switchboards	3	5-6
Masterphone Handsets	6	23-24
Masterphone Receivers	6	45
Masterbuilt Junior Switchboards	1	10-12
Masterbuilt Magneto Switchboards	1	3-7
Masterbuilt PBX Switchboards	3	2-6
Masterbuilt Switchboards		
Junior	1	10-12
Magneto	1	3-7
Multiple Type	1	13-18
PBX	3	

General Index

GENERAL INDEX

M (continued)

	Sec. No.	Page No.
Masterphone		
Transmitters	6	46
Masterphones		
Common Battery	6	10-22
Magneto	6	10-29
Matlock Cable Rollers	8	70
Mauls, Wood Faced	8	4
Mazda Lamps	5	21
Measuring Tapes	8	102
Melting Pots	8	109
Messenger Dead Ends	8	58
Messenger Hangers	8	55
Message Meters	5	23
Messenger Strand	8	134
Metal Flags	8	111
Metal Handsets	6	34
Metal Rim Tags	8	73
Meters	8	87-91
Frequency	4	17
Message	5	23
Mica Dielectrics	8	15
Mica Fuses	8	14
Milonite Nails	8	77
Motor Generator Sets	4	18-19
Moulding		
Cable	8	9
Ground Wire	8	9
Strain Plates	8	58
Tree	8	9
Mountings, Clear Out		
Drops	5	11-14
Coil	8	15
Condensers	5	8
Drop	5	
Drop and Jack	5	11-13
Jack	5	17
Key	5	
Message Meters	5	23
Order Wire Keys	5	32
Relay	5	42-43
Repeating Coil	5	5
Retardation Coils	5	6
Tel. Extension Arms	6	30
Telephone Mouthpieces	6	33-46
Supports	8	130
Multiple Type Masterbuilt Switchboards	1	13-18
Multi-Size Screw Anchors	8	80
Muslin Splicing Tape	8	74

N

Nails		
Galvanized	8	77
Interior Wiring	8	77
Milonite	8	77
Pole Dating	8	77
Neatsfoot Oil	8	118
Neck Band Clamps	8	37
Non-Breakable Messenger Hangers	8	55
Neckbands, Paper	8	37

N (continued)

	Sec. No.	Page No.
No. 1000 Type Cam Keys	5	25-35
No. 2000 Type Relays	5	40-42
Noise Killer Condensers	4	12
Non-Adjustable Ringers	6	43
Non-Biased Ringers	6	42
Non-Positional Transmitters	6	3-46
Northern White Cedar Poles	8	149-153
Number Plates	5	22
and 6	8	86
36	8	36
Nuts, Thimbleye	8	57
Nuts, Twineye	8	57
O		
Offset Dead End Sleeves	8	85
Oil Field Telephones	6	31
Oil, Neatsfoot	8	118
Ohmmeters, Weston	8	88
Okonite Tape	8	74
One-Piece Bakelite Transmitter Fronts	6	46
One-Piece Ringers	6	42-43
Operator's Breastplate Sets	5	37
Operator's Chairs	8	44
Operator's Feed Coils	5	3
Operator's Cords	7	12-13
Operator's Neck Bands	8	37
Operator's Plugs and Jacks	5	20
Operator's Receivers	5	37-38
Operator's Transmitters	5	37
Order Wire Key Mountings	5	32
Order Wire Keys, Push Button Type	5	31-32
Outdoor Telephones	6	26-33
Oval Eye Anchor Rods		4

P

Pads, Climber	8	117
Paint, Cable	8	76
Panels, Toll Test	1	21
Paper Neck Bands	8	37
Paper Sleeves	8	73
Paper, Tarred Felt	8	76
Paraffin	8	73
Parallel Drop Wire	8	136-137
Parallel Drop Wire Clips	8	49
Parolite Compound	8	76
Pasters, Cable	8	73
Paste, Soldering	8	72-73
Patching Cords, (\$wbd.)	7	15
Pay Out Reels	8	131
Pay Out and Take Up Reels	8	131-132
Pay Stations	8	25-27
Pay Station Signs	8	24
P. & B. Compound	8	76
PBX Switchboards, Cordless	3	5-6

P (continued)

	Sec. No.	Page No.
PBX Switchboards, Relaymatic	2	8
PBX Switchboards, Masterbuilt	3	2-6
P. & B. Tape	8	74
"P" Clamps	8	49
Peavies	8	131
Pedestal Type Telephones	6	24-28
Phantom Coils	5	4
Phillips Drivers	8	81
Phillips Screws	8	81
Phileo Storage Batteries	4	11-12
Phonometers	8	37
Piece Parts		
Cam Keys	5	33-35
Clear Out Drop Mountings	5	14
Combined Drop and Jack Mountings	5	13
Drops and Jacks, Combined	5	10
Four Party Keys	5	36
Telephones	6	10-32
Desk Set Boxes	6	23-38
Pike Poles	8	129
Pike Poles, Guarded	8	130
Pike Pole Guards	8	129
Pine Cross Arms	8	7
Pine Poles	8	143-149
Pins		
Corner	8	8
Dowel	8	41
Duplex	8	8
Indicator	5	24
Insulator	8	8
Jack Mounting	5	23
Locust	8	8
Steel	8	8
Transposition	8	8
Turn	8	108
Wood	8	8
Pipe Connectors	8	41
Pipe Pushing Jacks	8	123
Pipe Straps	8	9
Platform Ladders	8	68
Platforms, Pole	8	64
Plates, Butt	8	58
Plates, Guy Hook Strain	8	57
Plates, Lift	8	56
Plates, Number	5	24
Plates, Strain and Moulding	8	58
Plier Pockets	8	120
Pliers	8	98-100
Plug Cushions, Rubber	7	16
Plugs, Drift	8	108
Plug Hole Blanks	5	19
Plugs and Jacks, Operator's	5	20
Plugs and Jacks, Wall Outlet	6	35
Plug Seats	5	19
Plugs, Switchboard	5	18-19
Plumber's Candles	8	73
Pocket		
Ammeters	8	88
Tool Cases	8	120
Tool Kits	8	120

GENERAL INDEX

P (continued)

	Sec. No.	Page No.
Pocket (continued)		
Tool Rolls	8	120
Voltmeters	8	88
Pockets, Plier	8	120
Polarized Relays	5	43
Pole Changer Filters	4	17
Pole Changer Test Sets	4	17
Pole Changers	4	16
Poles	8	142-153
Pole		
Balconies	8	64
Bits	8	94
Brackets, Channel	8	59
Dating Nails	8	77
Extensions	8	53
Line Hardware	8	48-65
Markers	8	86
Pike	8	129
Pullers	8	125
Pulling and Straightening Jacks	8	123
Porcelain		
Fuses	8	14
Insulators	8	66
Knobs	8	67
Tube Cutters	8	101
Tubes	8	67
Portable Electric		
Cleaners	8	34
Portable Telephones	6	32
Posts, Binding	6	36
and	8	39
Posts, Fuse	5	2
Pot Head Compound	8	76
Pot Head Wire	8	138
Pots, Melting	8	109
Pouring Ladles	8	109
Power Apparatus	4	9-21
Power Cable	7	18
Power Switchboards	4	21
Power Units	4	15
Prest-O-Lite Equipment	8	112-113
Premax Markers	8	86
Private Branch Exchange Switchboards	3	2-6
and	2	8
Protected Cable		
Terminals	8	16-18
Protection Equipment	4	2-8
Protectors		
Central Office	4	4-8
Coil	8	15
Guy Wire	8	60
Main Frame	4	4-8
Sub-Station	8	10-13
Protector		
Fuses	8	14
Gloves	8	102
Units	8	16
Pruners	8	103-106
Pruning Saws	8	103-106
Pulling Grips	8	133
Pulling-In Irons	8	71
Pullers, Fish Tape	8	92
Pulley Blocks	8	122
Pulley Blocks, Capstan	8	124
Pulley Life-Line	8	124
Push Buttons	8	21

P (continued)

	Sec. No.	Page No.
Push Button Keys	5	31-32
Push Drills	8	95
Pushers	8	125
Push-Pull Jacks	8	125

R

Racks, Battery	4	12
Racks, Connecting	6	39
Racks, Underground		
Cable	8	69
Raising Forks	8	130
Railway Dispatching		
Receivers	6	45
Railway Telephones	6	30-31
Ratchet Braces	8	95
Ratchet Screw Drivers	8	96
Raytheon		
Rectichargers	4	13
Raytheon Rectifiers	4	15
"R" Clamps	8	49
Readrite Meters	8	88
Receiver Cords	7	11
Receiver Hooks	6	41
Receivers, Operator's	5	37
Receivers, Telephone	6	45
Rectichargers	4	13
Rectifiers, Fansteel		
Balkite Taper	4	14
Rectifiers, Raytheon	4	15
Reducing Sleeves	8	85
Reel Jacks	8	123
Reels		
Adjustable	8	132
Barrow	8	121
Drop Wire	8	132
Fish Tape	8	92
Jumper Wire	8	132
Pay-Out	8	131
Reel Wheels	8	70
Reinforcing Straps	8	8, 55
Reinforcing Links	8	54
Relays	5	39-43
Alternating Current	5	41
Polarized	5	43
Relaymatic	5	45
Telecode	8	83
Trip and Restoring	5	42
2000 Type	5	40-42
Vincent Rare Gas	8	91
Relay Coils	5	41-45
Rela-Flo-Tests	8	91
Relaymatic		
PBX Switchboards	2	8
Relays	5	45
Selectors	2	7
Switchboards	2	2-7
Relay Mountings	5	42-43
Reliable Line Terminal		
Blocks	4	8
Reliable Main Distributing Frames	4	7
Reliable Switchboard		
Protectors	4	8
Repair Sleeves	8	85
Repeaters	5	46
Repeating Coils	5	4
Resistance Coils	5	7
Restoring Relays	5	42

R (continued)

	Sec. No.	Page No.
Retardation Coils	5	5
Retractable Instrument		
Cords	8	33
Reversible Point Pike		
Pole	8	129
Rheostats	8	111
Ribbon, Bonding	8	73
Ribbons, Calculagraph	8	36
Richards Utility Pole		
Trailers	8	92
Ringer Drop and Jack	5	12
Ringing Converters	4	19-20
Ringing Dynamoter	4	18
Ringing Equipment	4	18-20
Ringing Machines	8	141
Ring Motor		
Generator Sets	8	18
Ring Sets	4	18
Rings		
Bridle	8	80
Cable	8	78-79
Drive	8	80
Ringers	6	42-44
Ripping Hammers	8	96
Rods		
Anchor	8	4
Cable Duct	8	71
Conduit	8	71
Ground	8	62
Rollers, Cable	8	70
Rope, Manilla	8	74
Rosin Core Solder	8	72
Rubber Covered		
Underground Wire	8	140
Rubber Gloves	8	102
Rubber Grip Drill		
Holders	8	93
Rubber Insulating		
Bandage	8	74
Rubber Tape	8	74

S

Saddles, Cable Ring	8	73
Safety Chairs	8	107
Safety Belts	8	118
Safety Compound		
Kettles	8	108-116
Safety Harness	8	118
Safety Load Binders	8	124
Safety Pull Hoists	8	124
Safety Straps,		
Linemen's	8	118
Salts, Soldering	8	72-73
Samson Installing		
Wrenches	8	65
Samson Stubbing		
Clamps	8	65
Sanitary Paper		
Neckbands	8	37
Saws, All Types	8	103-105
Sawtooth Discharge		
Blocks	8	15
Savers, Battery	6	36
Scissors, Electrician's	8	108
Screw Anchors for		
Wood Screws	8	80
Screw Drivers	8	97

General Index

GENERAL INDEX

S (continued)

	Sec. No.	Page No.
Screw Eyes, Insulated	8	67
Screw Hooks	8	49
Screws		
Angle	8	48
Lag	8	50
Phillips	8	81
Wood	8	81
Seats, Plug	5	19
Seats, Pole	8	64
Self-Tying Knobs	8	67
Senior Test Cabinets	1	19
Serjdetour Protectors	8	13
Set Back Ratchet		
Counters	8	37
Sets, Operator's	5	37-38
Sets, Test	6	32
Shackles, Dead End	8	59
Shafts, Generator	5	47
Shave Hooks	8	108
Shears, Pruning	8	106
Sheaves, Cable	8	71
Sheaves, Manhole	8	71
Sheath Splitting Knives	8	108
Shields, Cable Duct	8	71
Shims, Pole	8	58
Showels	8	126-128
Shovel Handles	8	126-128
Side Brackets	8	8
Signals, Industrial	8	82-83
Signs, Warning	8	111
Signs, Pay Stations	8	24
Sirens	8	82
Side-Mounting		
Masterphones	6	18-27
Skids and Sheaves	8	71
Slack Pullers	8	125
Sleeve Clamps	8	100
Sleeves		
Cable Repair	8	75
Copper	8	84-86
Cotton	8	73
Lead	8	72
Nicopress	8	84-85
Paper	8	73
Splicing	8	84-86
Steel	8	84-86
Trouble	5	19
Slick Digging Tools	8	128
Snaps, Klein	8	118
Snatch Blocks	8	122
Snub-R-Grip Wire		
Holders	8	49
Socket Wrenches	8	11, 101
Socket Framing Chisels	8	94
Solder & Soldering		
Supplies	8	72-74
Solder		
Coppers	8	111
Copper Handles	8	111
Irons	8	110
Iron Holders	8	110
Liquid	8	72-73
Paste	8	72-73
Pots	8	109
Pot Stands	8	108
Salts	8	72-73
Stick	8	72
Southern Yellow Pine		
Poles	8	142-149

S (continued)

	Sec. No.	Page No.
Spacers, Pipe	8	65
Span Brackets	8	48
Span Clamps	8	48
Special Purpose		
Switchboards	3	7-10
Specifications and Cord		
Drawings	7	6-15
Special Telephones	6	30-32
Special Sets	6	30-32
Spikes, Galvanized	8	77
Splicers Furnaces	8	115-116
Splicing Clamps	8	100
Splicing Sleeves	8	84-86
Splicing Tape	8	74
Spoon Handles	8	126-127
Spoons, Digging	8	126-127
Spuds, Digging	8	128
Spring Jacks	5	15-17
Staples		
Copperweld	8	9
Galvanized	8	9
Ground Wire	8	9
Insulated	8	77
Stands, Desk	6	24-28
Star Drills	8	93
Stations, Pay	8	25-27
Staysalite Torches	8	113
Stearine Candles	8	73
Steel Desk Set Boxes	6	24
Steel Telephone Sets	6	18-33
Steel Pulling Blocks	8	122
Steel Strand	8	134
Steel Tape	8	102
Step Ladders	8	68
Steps		
Iron Pole	8	63
Manhole	8	69
Wood Pole	8	8
Storage Batteries	4	9-12
Stove Bolts	8	48
Straight Counters	8	37
Strain Insulators	8	67
Strain Plates	8	58
Strain Plates, Guy		
Hook	8	57
Strand Bands	8	61
Strand Connectors	8	54
Stranded Wire,		
Insulated	7	18
Strand Messenger	8	134
Strand, Steel	8	134
Straps		
Bracket Reinforcing	8	8
Conduit	8	71
Extension	8	118
For Climbers	8	117
Guy	8	54
Safety	8	118
Wall	8	54
Strippers, Braid and		
Wire	8	101
Strips, Designation	5	24
Stripping Knives	8	96
Strips, Distributing	8	19
Strips, Terminal	5	2
Struts, Pole	8	64
Stubbing Bands	8	65
Stubbing Washers	8	65
Sub-Cycles	8	141

S (continued)

	Sec. No.	Page No.
Sub-Cycle Ringing		
Converters	8	19-20
Sub-Station Protectors	8	10-13
Supports, Cable	8	78
Supports, Mule, Jenney	8	130
Surface Mounting Plugs		
and Jacks	6	35
Surveyor's Tape	8	102
Suspension Clamps,		
Cable	8	55
Suspended Type		
Operator's Sets	5	38
Suspended Type		
Switchboard Cords	7	10
Swinging Brackets	8	59
Switches	8	86
Switch, Foot	6	30
Switch Hook Levers	6	41
Switchboards		
Cordless, PBX	3	5-6
Magneto, Masterbuilt	1	3-7
Magneto Wall Type	1	8-9
Masterbuilt Cordless	3	5-6
Masterbuilt Junior	1	10-12
Masterbuilt Magneto	1	3-7
Masterbuilt Multiple		
Type	1	13-18
Multiple Type	1	13-18
PBX	3	2-6
Power	4	21
Relaymatic	2	2-7
Special Purpose	3	6-10
Toll	1	22
Type "K"		
Masterbuilt PBX	3	2-4
Wall Type, Magneto	1	8-9
Switchboard Cable	7	17
Switchboard Cords	7	14-15
Switchboard Generators	5	47
Switchboard Lamps	5	21
Switchboard Parts		
and Apparatus	5	2-48
Switchboard Patching		
Cords	7	15
Switchboard Plugs	5	18-19
Switchboard Protectors	4	4, 6, 8
Switchboard Tools	5	47-48
Switchboard		
Transmitters	5	37
Switchboard		
Transmitter Arms	5	38
Switchboard Wire	7	18

T

Table, Drop Wire Sag	8	137
Table, Wire Gauge	8	140
Tackle Blocks	8	121
Tags		
Embossed	8	86
Metal Rim	8	73
Terminal	8	73
Take-up Reels	8	132
Tamping Bars	8	128-129
and Jacks	8	4
Tanks, Prest-O-Lite	8	113
Tape, Adhesive Joint	8	41
Tape, All Types	8	74

GENERAL INDEX

T (continued)

	Sec. No.	Page No.
Tape, Measuring	8	102
Taper Rectifiers	4	14
Tarred Felt Paper	8	76
Telephone Cable Wire	7	18
Telecode Relays	8	83
Telefans	8	35
Telefault	8	87
Teleheight	8	92
Teleohm	8	90
Telering	8	141
Teleshelf	8	24
Telespot	8	89
Tele-Trol	8	37
Telephones		
Common Battery	6	10-26
Magneto	6	18-28
Telephone Extension		
Arms	6	30
Telephone Mouthpieces	6	46
Telephone Tools	6	36
Telkor Telespot	8	89
Tel-Tile	8	43
Temperometers	8	115
Tent, Cable Splicers	8	107
Tent, Miner's	8	107
Terminal Blocks	4	6-8
Terminals, Building	8	19
Terminal Boxes, Steel	8	19
Terminals, Cable	8	16-18
Terminal Fuses	8	14
Terminal Strips	5	2
and 8		19
Terminal Tags	8	73
Test Boards	8	108
Test Cabinets	1	19-20
Test Clips	8	39
Test Connectors	8	39
Test Jack and Switch	5	45
Test Mandrels	8	70
Test Panels, Toll	1	21
Test Poles	8	91
Test Sets	6	32
and 8		87-91
Test Sets, Pole Changer	4	17
Test Set Batteries	8	20
Testing Equipment	1	19-20
and 8		87-91
Thimbles, Wire Rope	8	57
Thimbleye Anchor Rods	8	4
Thimbleyes, Angle	8	57
Thimbleye Bolts	8	56
Thimbles, Guy	8	57
Thimbleyelets	8	57
Thimbleye Nuts	8	57
Through Bolts	8	50
Tie Wires	8	135
Timing Devices	8	36-37
Tips, Cord	7	16
Tips, Soldering Copper	8	100
Toll Test Panels	1	21
Toll Timers	8	36-37
Tone Generators	4	20-21
and 8		141
Toggle Bolts	8	38
Toggle Bridle Rings	8	80
Tool Bags	8	120
Tool Belts	8	119
Tool Kits	8	120
Tool Kits, for		
Drilling Plug Seats	5	19
Tool Rolls	8	120

T (continued)

	Sec. No.	Page No.
Tools, Cord	7	15
Tools, Switchboard	5	47-48
Tools, Telephone	6	36
Toll Switchboards	1	22
Torches, All Types	8	112-115
Transformers	8	141
Transformers for Use		
With Sub-Cycle	4	20
Transformer Sets	4	16
Transformers,		
Insulating	5	4
92		92
Trailers, Pole	8	90
Transmission Test Sets	8	90
Transmitter Arms		
(Swbd.)	5	38
Transmitter Arms		
(Tel.)	6	45
Transmitter Backs	6	46
Transmitter Batteries	8	20
Transmitter Cords	7	10-12
Transmitter Fronts	6	47
Transmitter Type		
Number Plates	6	36
Transmitters,		
Non-Positional	6	3-46
Transmitter		
Switchboard	5	37
Transmitters, Telephone	6	46
Transposition Brackets	8	52-53
Transposition Break		
Iron Brackets	8	53
Transposition Insulators	8	66
Transposition Pins	8	8
Tree Climbers	8	117
Tree Guards	8	9
Tree Moulding	8	9
Tree Pruners	8	104-106
Tree Trimmers	8	104-106
Tree Wire	8	138-139
Triad Circuit	6	7
Trimmers, Tree	8	104-106
Trip and Restoring		
Relays	5	42
Trouble-Man's Friend	8	89
Trouble Sleeves	5	19
Tru-Gap Dischargers	8	15
Tubase Guy Clips	8	54
Tube Cutters, Porcelain	8	101
Tubes, Porcelain	8	67
Turnbuckles	8	66
Turn Pins	8	108
Twine Lacing	7	17
Twine, Marline	8	74
Twineye Anchor Rods	8	4
Twineye Nuts	8	57
Twist Drills	8	93
Two Party Keys	5	30-31
Type "K" Masterbuilt		
PBX Switchboards	3	2-4

U

U-Bolts	8	52
U-Bolt Brackets	8	52
U Cable Guards		
and Straps	8	60
Underground Cable		
Racks	8	69

U (continued)

	Sec. No.	Page No.
Underground Cable		
Terminals	8	18
Underground Wire	8	140
Universal Messenger		
Hangers	8	55
Units, Power	4	15

V

Vacuum Arresters	8	13
Vacuum Cleaners	8	34
Vac-M Arresters	8	13
Ventilators	8	35
Vertical Braces	8	51
Vincent Rare Gas Relays	8	71
Voltmeters	8	88
Volt-Ohmmeters	8	88
Volt-Ohm		
Milliammeters	8	88

W

Wall Brackets	8	53
Wall Masterphones	6	12-20
Wall Outlet Phones	6	35
Wall Telephones		
Common Battery	6	12-25
Magneto	6	18-29
Wall Straps	8	54
Wall Type Magneto		
Switchboards	1	8-9
Wall Type Main		
Distributing Frames	4	3-7
Warning Signs	8	111
Washers, Round, Square		
Curved, Stubbing	8	50-65
Wax	8	73
Waxed Cotton Sleeves	8	73
Weatherproof Copper		
Tree Wire	8	139
Weatherproof Iron		
Tree Wire	8	139
Weatherproof Loud-		
ringing Bells	6	33
Weatherproof		
Telephones	6	26-33
Weatherproof Wire	8	139
Weights, Cord	7	16
Weed Burner	8	113
Western Red Cedar		
Poles	8	149-153
West Test Sets	8	87
Wheatstone Bridges	8	90-91
Wheels, Cable Reel	8	70
Winches, Cable Pulling	8	34
Window Ventilators	8	34
Wiping Cloths	8	109
Wiping Solder	8	72

Wire

Bare Iron	8	135
Bridle	8	138
Bronze	8	136-137
Conduit	8	139
Copper, Bare	8	140
Densheath	8	139
Drop	8	136-138
Duct	8	139

General Index

GENERAL INDEX

W (continued)

Wire (continued)	Sec. No.	Page No.
Electric Light	8	140
Flameproof Jumper Wire	7	19
Fuse	8	14
Generator Wire	7	18
Hi-Conducto	8	136-137
Interior	8	138
Ironite	8	138
Ironite, Tree	8	138
Jumper	8	139
Kellogg Armored Bronze	8	136-137
Lashing	8	73
Lead Fuse	8	14
Lead Sheathed Under- ground Cable	8	140
Parallel Drop	8	136-137
Pot Head	8	138

W (continued)

Wire (continued)	Sec. No.	Page No.
Power	8	140
Rubber Covered Underground	8	140
Spider	8	138
Stranded Wire	7	18
Tree	8	138-139
Twisted Pair Drop	8	136-138
Weatherproof	8	139
Weatherproof Iron Tree	8	139
Wire Clips	8	61
Wire Gauges, Table	8	106
Wire Grips	8	121
Windshields, Safety	8	116
Wire Chief's Test Panels	1	21
Wrecking Bars	8	95
Wrenches Lag Screw	8	101

W (continued)

Wrenches (continued)	Sec. No.	Page No.
Linemen's	8	101
Socket	8	11-101
Samson, Installing	8	65
Wood Desk Set Boxes	6	27-28
Wood Preservative	8	76

Y

Yellow Pine Crossarms	8	6-7
Yellow Pine Poles	8	142-149

Z

Zincs, Battery	8	21
Zinc Cable Hangers	8	79
Zinc-Wraps, National	8	79

Kellogg SWITCHBOARD PARTS AND APPARATUS

GENERAL CATALOG NO. 10

	Page
Drops (Clear Out) and Mountings.....	11 to 14
Coils, Switchboard	2 to 7
Drops and Jacks (Combined) and Mountings.....	9 to 13
Condensers	7 and 8
Escutcheons for Keys.....	27 to 32
Generators	47
Keys	
Cam, 1000 Type.....	25 to 27
Four Party Keys.....	29 and 30
Two Party Keys.....	30 and 31
Lamp Caps	21 and 22
Lamp Jacks	22 and 23
Lamps	21
Operator's Plugs and Jacks.....	20
Operator's Transmitters and Receivers.....	37 and 38
Plugs, Switchboard	18 and 19
Relays	40 to 43
Relay Coils	44 and 45
Repeaters	46
Spring Jacks	15 to 17
Tools, Switchboard	47 and 48

KELLOGG
SWITCHBOARD and SUPPLY COMPANY

6650 South Cicero Avenue, Chicago, Illinois

Branch Offices: Kansas City and San Francisco

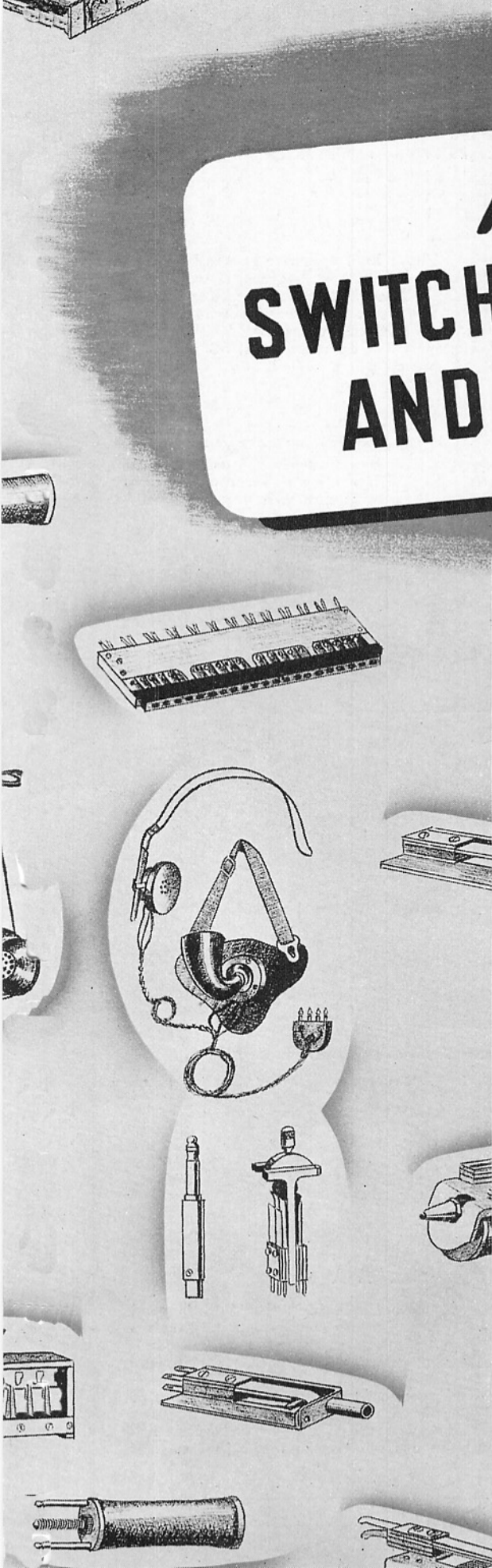

Switchboard Section

SWITCHBOARD APPARATUS

BUS BARS, HEAT COILS and TERMINAL STRIPS

Distributing Bus Bars (Fuse Posts)



Type No. 5



Left: Type No. 3



Right: Type No. 52

Distributing bus bars are used on switchboards for battery commons, ground strips and fuse terminals. They are made of rolled brass and are furnished with round head brass machine screws and washers.

Type No. 3 distributing bars have the center hole countersunk and the mounting holes of type No. 52 are tapped. Mounting holes on the rest of the distributing bars are countersunk and untapped. The terminal screws are spaced on $\frac{1}{2}$ inch centers on the bars with more than two screws.

Type No. 3

Center Hole is Countersunk

Code No.	Number of Terminal Screws	Dimension of Bus Bar, Inches		
		Length	Width	Thickness
3	2	1-3/16	1/4	1/4

Type No. 5

Mounting Holes Countersunk, Untapped

Code No.	Number of Terminal Screws	Dimension of Bus Bar, Inches		
		Length	Width	Thickness
5	5	2-9/16	3/8	1/4
10	6	3-1/16	3/8	1/4
60	7	6 1/2	3/8	1/4
15	9	4-9/16	3/8	1/4
16	10	5-1/16	3/8	1/4
18	11	5-9/16	3/8	1/4
19	13	6-9/16	3/8	1/4
23	16	8-1/16	3/8	1/4
39	28	14-1/16	3/8	1/4
57	21	14-1/16	3/8	1/4
43	25	12-9/16	3/8	1/4

Type No. 52

Mounting Holes are Tapped

Code No.	Number of Terminal Screws	Dimensions of Bus Bar, Inches		
		Length	Width	Thickness
52	2	1-3/16	1/4	1/4

Heat Coils

No. 2



These heat coils are carefully made and will blow at the amperage specified. The resistance varies between 3.8 and 4 ohms. This heat coil will operate on .5 ampere in less than 210 seconds and will carry .35 ampere for 10 minutes at 68° F. Fits the Kellogg No. 16 Arrester.

No. 6



No. 6 heat coil is used on Kellogg No. 1 arrester. The resistance is $3\frac{1}{2}$ ohms. This heat coil will operate on .5 ampere in less than 210 seconds and will carry 3.5 amperes indefinitely at 68° F.

Terminal Strips

With Screw Connectors

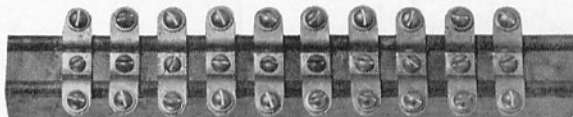

The connectors are made of steel, hot tin plated and are mounted on a hard maple strip, finished with shellac.

Code No.	No. of Lines	No. of Connectors	Length of Strip
41	5	10	7 1/2 inches
42	10	20	13 3/4 inches
43	25	50	32 1/2 inches

With Solder Connectors

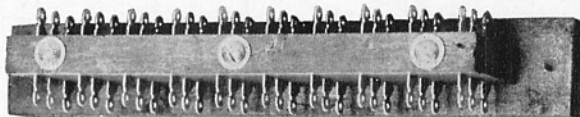

Clips are mounted in stained hard maple blocks.

Code No.	No. of Connectors	No. of Connectors per Row	No. of Rows High	Overall Length of Strip
34	10	5	2	3 3/8 in.
32	20	10	2	6 1/8 in.
31	30	10	3	6 1/8 in.
49	40	10	4	6 1/8 in.

INDUCTION COILS

No. 108-A



The primary winding of this universal local battery induction coil has a resistance of 1.3 ohms and the secondary a resistance of 11.1 ohms. Terminals are provided for either screw or solder connections. It is used in magneto switchboards using dry cells for primary batteries. The overall length is $4\frac{1}{4}$ inches, the spool heads are 1 inch square and the net weight is $4\frac{1}{2}$ ounces.

No. 81-A



No. 81-A induction coil is used with battery feed coils where operator's sets on magneto switchboards are supplied from 24-volt storage battery.

The primary winding has a resistance of 4 ohms and the secondary $37\frac{1}{2}$ ohms. Terminals are provided for either screw or solder connections. The spool heads are 1 inch square and the overall length is $4\frac{1}{4}$ inches. Net weight is $4\frac{1}{2}$ ounces.

INDUCTION COILS

No. 72-A

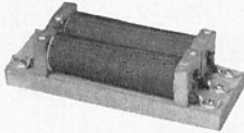

No. 72-A is used as the side tone reducing coil in large common battery multiple type switchboards as well as PBX switchboards. It consists of two coils mounted on a 2½ x 6 inch maple base, and wired to 5 terminals suitable for solder connections. The first winding of coil No. 1 has a resistance of 13 ohms and the second, 82 ohms. The first winding of coil No. 2 has a resistance of 13 ohms, and the second, 432 ohms. Overall height is 1¾ inches. Approximate net weight is 1 lb.

No. 7-A

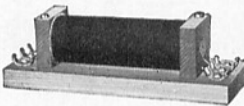

No. 7-A induction coil is used in common battery switchboards where a third or tertiary winding is desired for monitoring in connection with an operator's circuit having a relay type busy test. It is not anti-side tone.

The primary winding has a resistance of 65 ohms, the secondary, 90 ohms and the tertiary, 435 ohms. The coil is mounted on a 2-1/16 in. x 6 in. maple base and is wired to terminals suitable for solder connections. The approximate height is 2-1/16 inches and the net weight is 13 ozs.

No. 32-B

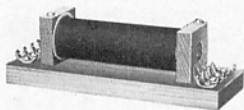

No. 32-B induction coil is used with an operator's circuit having a retardation type busy test. It has four windings, the two secondaries of which are wound parallel forming a split secondary. The primary winding has a resistance of 28½ ohms, the first secondary 135 ohms, the second secondary 135 ohms, and tertiary 425 ohms. It is mounted on a 2 x 6 inch maple base and is wired to terminals suitable for solder connections. The height overall is 1⅞ inches. Net weight is 1 lb.

No. 78-A

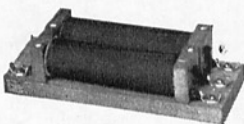

No. 78-A induction coil is similar to No. 72-A in appearance and in use, the difference being that No. 78-A has an additional resistance winding for high efficiency toll operator's circuit. On coil No. 1 the first winding has a resistance of 12 ohms, the second, 82 ohms and the third, 100 ohms. On coil No. 2 the first winding has a resistance of 12 ohms and the second 432 ohms. The size and weight are the same as for coil No. 72-A.

No. 35-A

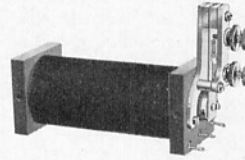

The No. 35-A induction coil is combined with an adjusting interrupter to change direct current into high frequency current to operate the Kellogg No. 2 howler.

The primary winding has a resistance of 1½ ohms, the secondary, 51½ ohms. Overall length is 4¾ inches, width is 2 inches and height is 3½ inches. The approximate net weight is 1½ lbs.

No. 66-A

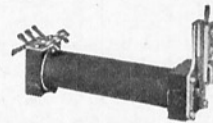

No. 66-A induction coil is a combined interrupter and induction coil for railroad telegraph sets. The primary winding has a resistance of 1.6 ohms and the secondary, 51½ ohms. The length is 3 inches, the width is 1 inch and the height is 2 inches. Net weight is ¾ lb.

No. 110-A

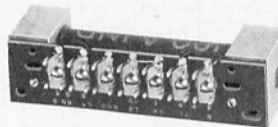

The No. 110-A local battery, anti-side tone induction coil is used in magneto switchboards. It has four windings, with resistances of 1.38 ohms, 10.30 ohms, 8.30 ohms and 600 ohms. The third and fourth windings are connected in series; the first three windings are concentric and the fourth is non-inductive. The primary is insulated from the secondary.

The overall dimensions are 4 inches long, 1-3/16 inches high and 1-3/16 inches deep. A seven point connecting rack is combined with this coil.

No. 111-A

The No. 111-A local battery, anti-side tone induction coil has four windings. The resistance of the first winding is 8.70 ohms, the second is 1.5 ohms and the resistance of the third and fourth windings which are connected in series is 600 ohms. The first three windings are concentric and the fourth is non-inductive; the primary is insulated from the secondary.

Overall dimensions are 3 inches long, 1 inch deep and 2¼ inches high. A six point connecting rack is combined with this coil.

No. 3-A Operator's Feed Coil

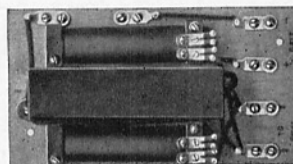

These No. 3-A coils are used in magneto switchboards with No. 81-A induction coils to supply operator's transmitter with current from storage battery. One No. 81-A induction coil and one battery feed coil is used for each position. These coils each consist of a 2 M. F. condenser in combination with two retardation coils, one in each side of the circuit. They are wound to secure the proper impedance to feed the right amount of current to the transmitter and prevent cross talk between positions. The base is of maple, 3¼ inches wide and 6 inches long. Net weight is 1½ lbs.

Switchboard Section

SWITCHBOARD APPARATUS

REPEATING COILS

Kellogg takes every engineering and manufacturing precaution to insure a superior coil that will meet the most exacting demands in both ringing and talking efficiency. The cores are made of silicon steel and the wind-

ings are completely enclosed in heavy cross talk proof cases. The transmission losses are considerably less than one half mile of standard cable. For additional information on repeating coils write for bulletin on No. 206.

Phantom Coils

No. 24-A, Ring and Talk Through

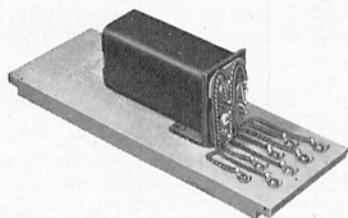

The No. 24-A repeating coil has extremely low transmission loss and is used with phantom circuits or for the termination of metallic lines which are continued as grounded or one-wire circuits.

The laminated nickel iron alloy closed core permits high efficiency on both the talking and ringing circuits. It is housed in a cross-talk proof shell cover. Windings are perfectly balanced. There are two parallel and two tandem windings with resistance of 20.6, 20.6, 25.5 and 25.5 ohms, respectively. It is mounted on a $10\frac{3}{4}$ x 4 in. maple base for convenient rack mounting. Terminals are brought out to numbered soldering connections on the wood base. It replaces Kellogg No. 17-F, and 18-A and 18-B repeating coils. Height overall is $3\frac{1}{4}$ inches. Shipping weight is 6 lbs.

No. 21-A, Ring and Talk Through

No. 21-A repeating coil is the same as No. 24-A except it is furnished without the maple base. It mounts on standard 2000 type relay strips or on individual relay mountings.

This coil is recommended only where there are standard Kellogg relay mounting strips or where space is at a premium. Overall length is $4\frac{3}{4}$ inches, width is $2\frac{3}{8}$ inches and height is $1\frac{7}{8}$ inches. Shipping weight is 3 lbs.

For mounting, use the repeating coil mounting brackets Nos. 1012, 1013 or 1014 shown on page No. 6.

No. 22-A

No. 22-A consists of two No. 21-A repeating coils. It is mounted on a maple panel that mounts on W. E. coil racks. This arrangement is particularly convenient for phantom circuits and saves space. All connections are brought out to numbered soldering connections on the base. Dimensions are the same as for No. 24-A. Shipping weight is 8 lbs.

No. 27-A, Ring and Talk Through

No. 27-A repeating coil is the same as No. 24-A except for the size of the base. The base of coil No. 27-A is 4 inches wide and 6 inches long.

Phantom and Drainage Coils

For proper protection for these coils see Arresters in the Lines Supplies Section of this catalog.

Balanced Coils for Metallic Phantoms

No. 18-A

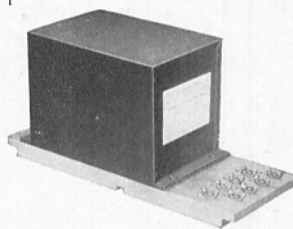

The No. 18-A repeating coil is balanced electrically as to capacity, resistance and impedance. It can be introduced at the center of two physical circuits in order to produce a split phantom which can be operated in either direction without interference to the physical circuits. It is adaptable to any

circuit requirement such as simplex and composite circuits where a well balanced coil is required. Ringing and talking efficiency is very high, the actual transmission loss being considerably less than one half mile of standard cable.

The four parallel windings of 5.7, 5.7, 7.5 and 7.5 ohms respectively are wired to eight terminals. It is mounted on a $10\frac{3}{4}$ x 4 inch wood base and arranged to mount on standard coil racks. Overall height is $5\frac{1}{8}$ inches. Net weight is 12 lbs.

Coils for Grounded Phantoms

No. 18-B

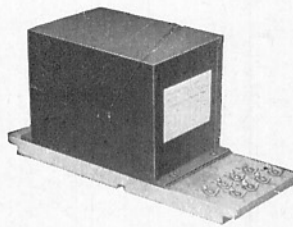

No. 18-B is similar to the No. 18-A except that it has two windings in tandem and two in parallel. It is more adaptable for use on rural phantoms, particularly grounded phantoms, as the windings being separated are less subject to lightning damage. Talk and ring through efficiency is practically the same as for the No. 18-A. Transmission loss is considerably less than one half mile. Resistance of windings, size of coil and base, weight, etc. are the same as for No. 18-A repeating coil.

ically the same as for the No. 18-A. Transmission loss is considerably less than one half mile. Resistance of windings, size of coil and base, weight, etc. are the same as for No. 18-A repeating coil.

Outdoor Coil Mountings

Refer to Line Supplies Section for outdoor type mountings for repeating coils.

Insulating Transformers

No. 19-B

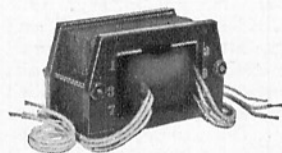

The 19-B insulating transformer is well balanced and withstands a breakdown test of 7500 volts. It can be used either as an insulating transformer or drainage coil on telephone lines paralleling high tension electric light

lines. The three single windings of 29, 58 and 29 ohms resistance are brought out with six heavy rubber covered

leads. It is furnished without cover or base and can be mounted as desired. The length is 7 inches, width is $4\frac{3}{4}$ inches and the height is $4\frac{1}{2}$ inches. Net weight is 17 lbs.

No. 19-A

No. 19-A insulating transformer has the same construction and dimensions as No. 19-B but it has four tandem windings and will stand a breakdown test of 5500 volts alternating current. The 19-A has eight flexible terminals which facilitate grounding either or both halves of the transformer for drainage purposes.

REPEATING AND RETARDATION COILS

Switchboard Type Repeating Coils No. 20-A, Talk Through Only

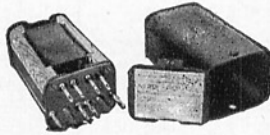

The No. 20-A repeating coil meets the demand for an efficient "talk through only" coil that can be mounted on standard relay mountings. Having four concentric windings of 12.1, 13.7, 15.2 and 16.6 ohms resistance, respectively, wound about a large core, it is unexcelled for use in magneto or other types of cord circuits to connect dissimilar lines together for communication purposes.

The No. 20-A coil is particularly suitable for magneto and universal cord circuits where a non-ring through feature is required. It is also used for common battery cord circuits where the battery feed is through the windings of the coil, also for toll and local and PBX trunks where the ring through feature is not desired. It has an open laminated iron core and is housed in a cross-talk proof shell cover.

Eight terminals are provided. The coil will mount in the same space occupied by two 1000 type relays. It will mount on standard 2000 type relay strip mountings and will also mount on the individual mountings shown at the right. Height overall is 1 7/8 inches, width 2 3/8 inches, and length 4 3/4 inches. Net weight less mounting is 2 1/4 pounds.

No. 16-A, Talk Through Only



The No. 16-A repeating coil has the same electrical characteristics and uses as the No. 20-A but is designed to mount on wood. Made of two concentric wound coils, each coil being placed upon one leg of a horseshoe lamination. Resistance of windings are 20, 16, 20, 16 ohms respectively. Height 3 3/4 inches, width 3-21/32 inches, length 2-5/32 inches. Net weight 3 pounds.

No. 19-A, Ring and Talk Through

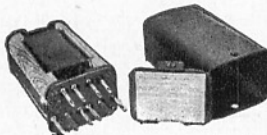

The No. 19-A repeating coil is similar in construction to the No. 20-A except the laminations are of the closed iron core type making a very efficient "ring and talk through" coil. It has a cross-talk proof shell cover and is ideal for use in magneto cord circuits. Should be used as a battery feed coil wherever a ring through coil is desired such as in cord or trunks circuits or in line circuits which are not phantom or simplexed.

Four concentric windings having resistances of 15.3, 17.1, 18.8 and 20.9 ohms respectively, connect to eight terminals. Mounts same as No. 20-A. Length overall is 4 3/4 inches, height is 1 7/8 inches and width is 2 3/8 inches. Net weight less mounting is 2 1/4 lbs.

Mountings for Repeating Coils

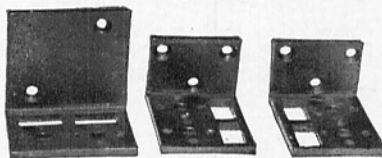

Code No.	Mounts On	Net Weight
1012	Right Side	6 oz.
1013	Left Side	6 oz.
1014	Top	6 oz.

Retardation Coils

The function of retardation or impedance coils in the telephone field is to feed battery and to isolate or limit fluctuating or alternating currents to some particular circuits. All conditions under which these coils are to be used, must be considered carefully and the proper coil selected to meet these conditions.

Kellogg retardation coils are made over a core of soft iron wire or on coils having laminated cores of silicon steel. The size of the enameled wire, the number of turns, the amount of iron in the coil, all are predetermined in Kellogg laboratories in order to make coils of the highest grade and efficiency.

Note: Refer to standard relay coils for retardation use. Also 2053 relay and 319 mounting.

Switchboard Type

No. 8 Type



The No. 8 type retardation coil is used in operator's circuits. The coil is mounted on a wood base and is connected to 2 terminals suitable for soldering. Overall length of the base is 6 inches and the width is 2 inches.

Code No.	Resistance	Code No.	Resistance
8-A	100 Ohms	8-C	350 Ohms
8-B	200 Ohms	8-H	165 Ohms

Type No. 9



The No. 9 type retardation coil is used in operator's circuits for battery feed coils. The overall length including terminals is 3-15/16 inches. The spool heads are 1 inch square.

Code No.	Resistance	Code No.	Resistance
9-B	150 Ohms	9-D	85 Ohms
9-C	200 Ohms	9-E	100 Ohms

Type No. 21

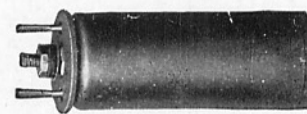

Type No. 21 coils are mounted in cross talk-proof individual shells as illustrated. These codes mount on the 2000 type mountings listed under relays on page No. 42 but not in pairs. The length of the shell is 3 3/8 inches and the diameter is 1-5/16 inches.

Code No.	Resistance in Ohms	Windings	No. of Terminals
21-B	100	Single	2
21-D	2000	Single	2
21-E	500	Single	2
21-J	300	Single	2
21-L	200	Single	2
22-B	100	Tandem	4
25-A	1000	Parallel	4
25-B	2000	Parallel	4
25-C	50	Parallel	4

Switchboard Section

SWITCHBOARD APPARATUS

RETARDATION COILS

Switchboard Type — Cont.

Type No. 56

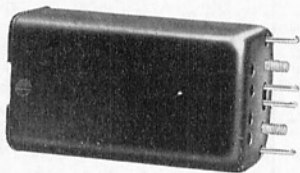

The No. 56 type retardation coil is placed in a standard relay shell cover. It mounts on the standard 2000 type relay mountings listed under Relays on Page No. 42. Dimensions of the can are 4 inches high, 29/32 inch wide and 1-13/16 inches deep.

Code No.	No. of Terminals	Resistance in Ohms		Winding
56-A	4	57	57	Tandem
63-A	2	500	...	Single
56-C	4	3.4	3.4	Parallel

Power Type

No. 23-A

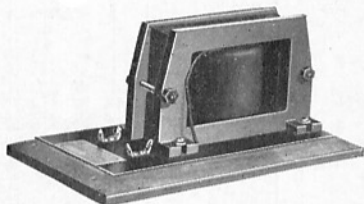

The No. 23-A retardation coil is used with harmonic type pole changers when a noise killer battery is used. The resistance of the single wound coil is .125 ohms. The wooden base is 11½ inches long and 6¾

inches wide. The height is 5 inches.

No. 41-A

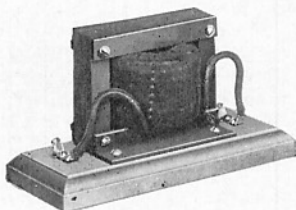

The No. 41-A retardation coil is used with single frequency pole changers and also a harmonic pole changer when noise killer battery is not used. The resistance of the single wound coil is .08 ohms. The base is 3 inches wide and 7 inches long. The height is 3¾ inches.

Miscellaneous Retardation Coils

Type No. 40

For Metallic Phantoms

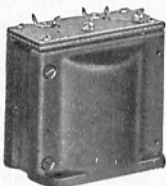

Similar in construction to Kellogg repeating coils, the No. 40-A has two balanced parallel windings for phantom work. The No. 44-A has two tandem windings for grounded phantoms. The base is 3¾ inches long, 2/8 inches wide and 37/8 inches high.

Code No.	Resistance		Winding
	First Winding	Second Winding	
40-A	45 ohms	45 ohms	Parallel
44-A	54 ohms	54 ohms	Tandem

No. 65-A



No. 65-A retardation coil is designed to reduce interference caused in radio sets by telephone ringing equipment. It is wound on a wood core. The inductance value is 3 millihenry and resistance is 2.75 ohms. Diameter is 2¾ inches and height is 1-1/16 inches.

Miscellaneous Retardation Coils—Cont.

No. 55-A

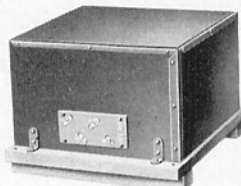

No. 55-A retardation coil is used as a composite balancing coil. It has four windings of 39 ohms each, balanced electrically as to capacity, resistance and impedance. It is mounted on a base and enclosed in an iron cover. The size of the base is 11 inches by 9¾ inches. The overall height is 7 inches.

Type No. 16



The No. 16 type retardation coil consists of a round steel core upon which is wound the single coil winding of copper wire. The No. 16-A is used in common battery desk stands of the retardation coil type and No. 16-C is used in No. 2869 composite telephones. The coil is 1 inch in diameter and 7/8 inch high.

Code No.	Resistance	Net Weight
16-A	33 ohms	2 oz.
16-C	4.5 ohms	2½ oz.

Battery Feed Coils

For Intercommunicating Systems



This type of relay coil is used for battery feed coils in intercommunicating telephone circuits. It has two concentric windings. The length not including terminals is 2¼ inches and the diameter is 1 inch. It replaces No. 14 type retardation coils. Mounts on the iron mounting strips shown below.

Code No.	Resistance in Ohms		Net Weight
CMA	50	50	5 oz.
CMB	100	100	5 oz.
CMF	250	250	5 oz.
CMG	25	25	

Mountings for Battery Feed Coils

These mounting strips are made of black enameled iron.

Code No.	No. of Coils Per Strip	Width of Strip	Length Overall
319	1	1-5/16 inches
163	10	1 inch	9-5/16 inches

No. 22-F Retardation Coil

For Intercommunicating Systems

No. 22-F retardation coil is similar in appearance to type No. 21 coil shown on page No. 5. It is the closed type, tandem wound, with two windings, each with a resistance of 50 ohms.

Mounting No. 487 for No. 22-F Retardation Coil

This mounting strip for No. 22-F retardation coil is made of steel, cadmium plated.

Code No.	No. of Coils Per Strip	Width of Strip	Length Overall
487	12	27/8 inches	11 inches

RESISTANCE COILS and CONDENSERS

Resistance Coils

Note: Also See Non-Inductive Relay Coils on Page No. 45.

Kellogg resistance coils are wound with enamel and silk insulated special resistance wire which has proven under test and in practice to be especially adapted to this service. These coils are made so that they can be mounted conveniently. Resistance coils can be furnished in the types illustrated below in any resistance.

Type No. 5

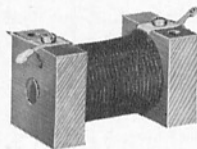

Consists of a small wood spool upon which the wire is wound and then soldered to two terminals. Spool heads are 1 inch square. Spool length is 1 3/4 inches. Overall length including the terminals is 2 inches.

Code No.	Resistance
5-A	10,000 ohms
5-B	15,000 ohms

Condensers

Kellogg condensers are manufactured by the most modern processes and with the best materials obtainable. The foil and paper are the finest the market affords. The impregnating compound is a special formula developed after years of laboratory research. To insure long life a special sealing compound is used. This compound will not crack at 0 degrees nor flow at 150 degree Fahrenheit.

Kellogg condensers are made to meet the maximum voltage that may be required in the class of work for which they are designed.

These working voltages are given below. In addition each condenser receives a fifteen second flash test of double the rated working voltage.

No. 20 .2 to .3 M. F.

Mounting ears are provided on the No. 20 condenser. Dimensions of can are 2 3/8 inches long, 1 1/4 inches wide, 3/4 inch thick. Working voltage 400 volts direct current.



No. 24 1/2 M. F.

The No. 24 is used on various types of pole changers, requiring a high break-down condenser. Overall, dimensions are 2 5/8 inches long, 2-1/16 inches in diameter. Working voltage 400 volts direct current.

No. 25 1 M. F.

The No. 25 condenser is the same as No. 24 except capacity. Working voltage 400 volts direct current.

No. 34 2 M. F.



The No. 34 condenser is mounted in a can, 4 3/8 inches long, 2-1/16 inches wide and 1 1/8 inches thick. Working voltage 200 volts direct current. Has mounting ears on sides and has the same appearance as

No. 103, shown on next page.

Condensers

No. 36 2 M. F.



The No. 36 condenser is designed to mount on an iron plate. Dimensions of can 4 3/8 inches long, 2-1/16 inches wide, 1 1/8 inches thick. Working voltage 200 volts direct current. The No. 36 mounts on the steel strips shown below.

Mounting for No. 36 Condenser



This type of enameled steel mounting is furnished as follows:

Code No.	Cond. per Strip	Width Inches	Mtg. Centers Inches	Length Overall Inches
272	11	2	13 1/2	13 7/8
289	18	2	25 1/4	26
335	16	2	20 3/8	21 1/8
356	10	2	13-1/16	13-13/16

No. 68 1/2 M. F.



The No. 68 condenser is for use in older type magneto switchboard cord circuits. The can is 3 1/2 inches long, 1 1/2 inches wide and 1-1/32 inches thick. The working voltage is 400 volts direct current. Equipped with mounting ears.

No. 37 1 M. F.

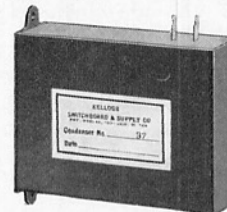

The No. 37 condenser is used in old style magneto switchboard cord circuits. Dimensions of the can are: 2 3/8 inches high, 3 inches wide and 1 inch thick. The working voltage is 200 volts

D. C. Can has mounting ears.

No. 62 2 M. F.

The No. 62 condenser is similar in appearance to the No. 68 shown above except that no mounting ears are provided. Dimensions of the can are 3 inches long, 1 1/2 inches wide and 1-1/32 inches thick. Working voltage 160 volts direct current.

No. 64 2 M. F.

The No. 64 condenser mounts on a steel relay mounting strip. Dimensions are 3-15/64 inches long, 1-1/32 inches wide and 21/32 inches thick. Working voltage 160 volts direct current.

No. 66 2 M. F.

The dimensions of No. 66 condenser are 3 1/8 inches long, 1 1/2 inches wide and 21/32 inches thick. The No. 66 condenser is the same as No. 68 except capacity and the working voltage is 160 volts direct current. Equipped with mounting ears.

Switchboard Section

SWITCHBOARD APPARATUS

SWITCHBOARD CONDENSERS

No. 67

1 M. F.

The No. 67 condenser is used in magneto cord circuits. Working voltage is 200 volts direct current. The dimensions are 3 1/4 inches long, 1 1/2 inches wide and 1-1/32 inches thick. Equipped with mounting ears.

No. 103

1 M. F.



The No. 103 condenser has mounting ears on the side. The can is 3 inches long, 1 1/2 inches wide and 1-1/32 inches thick. Working voltage is 200 volts direct current. Equipped with mounting ears.

No. 108

4.2 M. F.

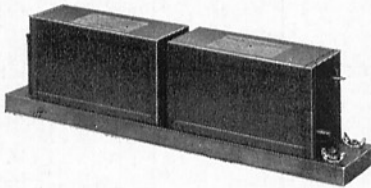

The No. 108 condenser consists of two No. 102 balanced condenser units mounted on a maple block. Overall dimensions are 10 3/4 inches long; 1 7/8 inches wide and 2 7/8 inches high. Working

voltage is 700 volts direct current.

No. 102

2.10 M. F.

The No. 102 condenser is accurately calibrated for use with the No. 108 twin condenser unit shown above. The can is 4-19/64 inches high, 2 1/8 inches wide and 1-11/16 inches thick. Working voltage is 700 volts, direct current. Has mounting ears.

No. 128

2 M. F.—2 M. F.



The No. 128 consists of twin 2 M. F. condensers placed in a regular relay shell. Provision is made for mounting on regular relay mounting strips. The shell is 4 inches long, 1 7/8 inches wide, and 2 1/4 inches thick. Working voltage is 200 volts.

No. 132

1 M. F.



The No. 132 condenser is arranged to mount on steel mounting strips. The can is 3-15/64 inches long, 1-13/32 inches wide and 27/32 inches thick. Working voltage is 200 volts direct current.

No. 140-C

1 M. F.

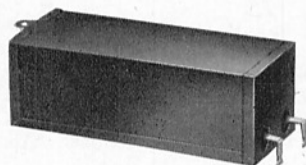

The No. 140-C condenser is the same as the No. 140 but is provided with a cover. Dimensions are 4-13/32 inches long, 1-11/16 inches wide and 9/16 inches thick. Working voltage is 700 volts direct current.

No. 141

1/8 to 1/2 M. F.

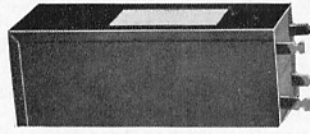

The No. 141 condenser is equipped with four terminals providing one common and three taps of 1/8, 1/4, or 1/2 M. F. The can is 4 3/8 inch long, 1 3/4 inches wide and 1-1/16 inches thick.

Working voltage is 700 volts direct current. No. 141 replaces W. E. No. 21-AB.

No. 143

1/4 M. F.

The No. 143 condenser is similar in appearance to the No. 141 condenser except No. 143 has only two terminals. Dimensions are 4-13/32 inches long, 1-11/16 inches wide and 1-1/16 inches thick. Working voltage is 700 volts direct current. No. 143 replaces W. E. No. 21-Y.

No. 197

1/4 M. F.

No. 197 condenser uses the same can as No. 64. It is 3-15/64 inches long, 1-13/32 inches wide and 27/32 inches thick. The working voltage is 160 volts direct current.

No. 205

.005 M. F.



No. 205 condenser has a paper tube type capacitor and bare wire leads. It is enclosed in

a phenol tube 1 1/2 inches long with a diameter of 3/8 inch. The condenser has a working voltage of 400 volts direct current. It is used in type 2-A power units.

No. 208

1/4 M. F.

No. 208 condenser is similar in appearance to No. 205 except the two leads of No. 208 are insulated. The working voltage is 400 volts direct current. Diameter is 3/8 inch and length is 1 1/2 inches.

No. 212

3 M. F.

No. 212 condenser is similar in appearance to No. 128. It consists of three 1 M. F. condenser windings mounted in can, 4 inches long, 2 1/4 inches wide and 1-13/16 inches thick. This condenser is used in the Kellogg pole changer filter.

No. 213

4 M. F.

No. 213 condenser is similar to No. 108 but is used for higher voltages. It is used with the Kellogg pole changer filter. The can is 4 inches long, 2 1/4 inches wide and 1-13/16 inches thick. Working voltage is 400 volts direct current.

No. 2-A

.01 to .10 M. F. in .01 Setps

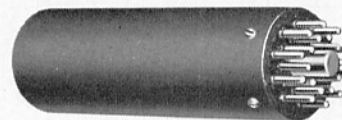

Plug type, used on multi-repeater stations.

No. 2-B

.11 to .20 M. F. in .01 Steps

No. 2-B condenser is similar in appearance to No. 2-A. It is used on multi-repeater stations.

Condenser Mounting Brackets

Piece No.	Thickness of Condenser
5771	3/4 inch
5772	1-1/32 inches
27928	1 1/2 inches
4854	2-1/16 inches

COMBINED DROPS and JACKS

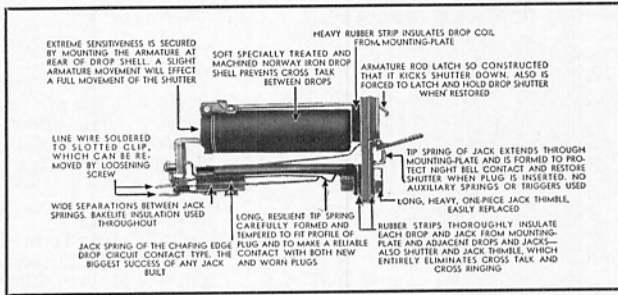

The Kellogg combined drop and jack is extremely sensitive. It operates with a minimum current, and gives a good clear signal. The mechanism is designed so the drop shutter will always restore even if the plug is badly worn. Kellogg drops and jacks are practically free from trouble and burn-outs.

If you will look at the picture above you will see how well the Kellogg drop insures positive operation. The armature which operates the latch is at the back end of the coil. This permits the use of a longer latch rod, with more positive action because the armature can be set closer and pulled up easier by weaker current. The slightest movement of the armature will cause full movement of the latch. The latch, as it is constructed, not only releases the shutter but kicks it down at the same time. Because of this feature the operation of Kellogg drops is more positive, even on heavily loaded lines where the ringing current is weak.

The outstanding feature of the Kellogg combined drop and jack is the extreme simplicity of construction and freedom from trouble. The long combined tip and restoring spring of heavy, even tempered German silver is the only spring making contact with the plug. The action of this spring places all jack wear on the inexpensive and easily replaced jack thimble. A positive electrical contact is always insured.

The break contact spring which cuts one side of the drop off from the line when the plug is inserted, is also constructed of heavy German silver being so formed that the chafing knife edge always makes a good electrical contact.

The drop shutter is of the punched hinged type construction and falls to an angle of 65 degrees when released. The shutter is plainly visible from any angle.

Kellogg Night Alarm

The Kellogg night alarm has been proven by many years of service. Here again, a long flexible spring having a non-corrosive contact insures maximum operation.

The code ringing night alarm, often called the armature contact, is separate from the regular night alarm. It is easily adjusted from the face of the switchboard.

Heavy insulators separate the springs, and thick blocks of hard rubber insulate drops and jacks from the frame, insuring maximum protection against lightning and other foreign current. Coils are easily removable but the liberal insulators make such removal rarely necessary.

Kellogg drops and mountings can be used in boards of other manufacture. In ordering give board number if Kellogg, if otherwise name of manufacturer and dimensions of the mounting.

Standard Combined Drops and Jacks

No. 300 and 301, 2-Conductor, Single Cut Off

The No. 300 combined drop and jack is provided with code ringing night alarm. An adjustment screw protrudes

through the mounting strip, allowing easy, positive adjustment.

No. 300 and 301 combined drops and jacks are standard in current Kellogg magneto drop supervision switchboards.

No. 301 combined drop and jack is standard where the code ringing feature is not desired. It will mount on the same type of mounting as the No. 300 type.

In ordering indicate the resistance of the winding of the drop coil desired. This resistance may be indicated by using the letters in the table below along with the code number of the drop and jack. For example Code No. 301-DJE drop and jack has a coil whose resistance is 500 ohms. If the drops and jacks are to be mounted specify the code number of the mounting.

Code No.	Resistance		Plug Used
	500 Ohms	1000 Ohms	
300	DJE	DJC	42
301	DJE	DJC	42

Piece parts for No. 300 and No. 301 are shown on page 10.

Drop and Jack to Fit W. E. 47 Plug

2-Conductor — Single Cut Off

No. 303 drop and jack fits the W. E. 47 plug. It is identical with the No. 301 except for the different jack thimble. Use No. 395 mounting shown on page No. 11.

Code No.	Resistance		Fits Plug
	500 Ohms	1000 Ohms	
303	DJE	DJC	130

Drop and Jack for Toll Lines

2-Conductor — Double Cut Off

No. 103 drop and jack is similar in construction to No. 301 except that the jack is provided with double cut off springs to cut the drop coil completely out of the circuit when plug is inserted.

Code No.	Resistance		Plugs Used
	500 Ohms	1000 Ohms	
103	DJE	DJC	42

Drop and Jack for Rural Lines Common Battery Switchboards

3-Conductor — Single Cut Off

No. 105 drop and jack is similar in construction to No. 103 but fits a three conductor plug.

Code No.	Resistance		Plugs Used
	500 Ohms	1000 Ohms	
105	DJE	DJC	106

For Rural Toll Lines, Common Battery Switchboard

3-Conductor — Double Cut Off

No. 107 drop and jack is similar to No. 105 except it is provided with a double cut off so that the drop coil is cut from the line completely when the plug is inserted.

Code No.	Resistance		Plug Used
	500 Ohms	1000 Ohms	
107	DJE	DJC	106

Switchboard Section

SWITCHBOARD APPARATUS

COMBINED DROPS and JACKS--PIECE PARTS

Drop and Jack for Dial Trunks

2-Conductor — Double Cut Off

No. 113 drop and jack is two conductor, and has double cut off springs and one make contact.

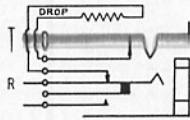

Code No.	500 Ohms	1000 Ohms	Plug Used
113	DJE	DJC	42

Coils Only for Drops

Standard drop and jack coils for Kellogg combined drops and jacks. They are quickly and easily replaced in the mounting.

Code No.	Resistance	Code No.	Resistance
DJA	100 ohms	DJC	1000 ohms
DJE	500 ohms	DJS	2500 ohms

Piece Parts Used in No. 300 Combined Drop and Jack

No. of Pieces	Piece Number	Description
1	42225	Sleeve
1	10001	Washer
Drop Parts Assembly 39637		
1	4813	Armature
1	2928	Armature Support
2	11758	Pivot Screw Assem.
2	59581	Rivet
1	25761	Cont. Spring
1	2233	Hook
1	25769	Cont. Screw Assem.
2	17795	Insulation
1	25766	Washer
1	39561	Terminal
2	16216	Bushing
1	39635	Shell
1	16106	Washer

Piece Parts No. 300 — Cont.

No. of Pieces	Piece Number	Description
1	10639	Screw, R. H. Mach.
2	56900	Screw, R. H. Mach.
1	1164	Screw, F. H. Mach.
1	12897	Screw, F. H. Mach.
2	56522	Screw, R. H. Mach.
Spring Jack Assembly 39551		
1	39470	Cont. Spring
1	39467	Cont. Spring Assem.
1	39474	Spring with Contact
1	39476	Terminal
1	39478	Terminal
1	10077	Frame
2	18071	Insulation, Thick
2	18070	Insulation, Thin
2	1263	Terminal
2	18069	Terminal
2	2936	Bushing
4	10369	Screw
2	10485	Screw

Piece Parts Used in No. 301 Combined Drop and Jack

No. of Pieces	Piece Part No.	Description
1	42225	Sleeve
1	10001	Washer
Drop Assembly No. 39638		
1	1086	Armature
1	2928	Armature Support
2	11758	Pivot Screw Assem.
1	2233	Hook
1	1161	Shell
1	16106	Washer
1	1164	Screw
1	12897	Screw
2	56522	Screw
Spring Jack Assembly No. 39551		
Same as for No. 300 Combined Drops and Jacks.		

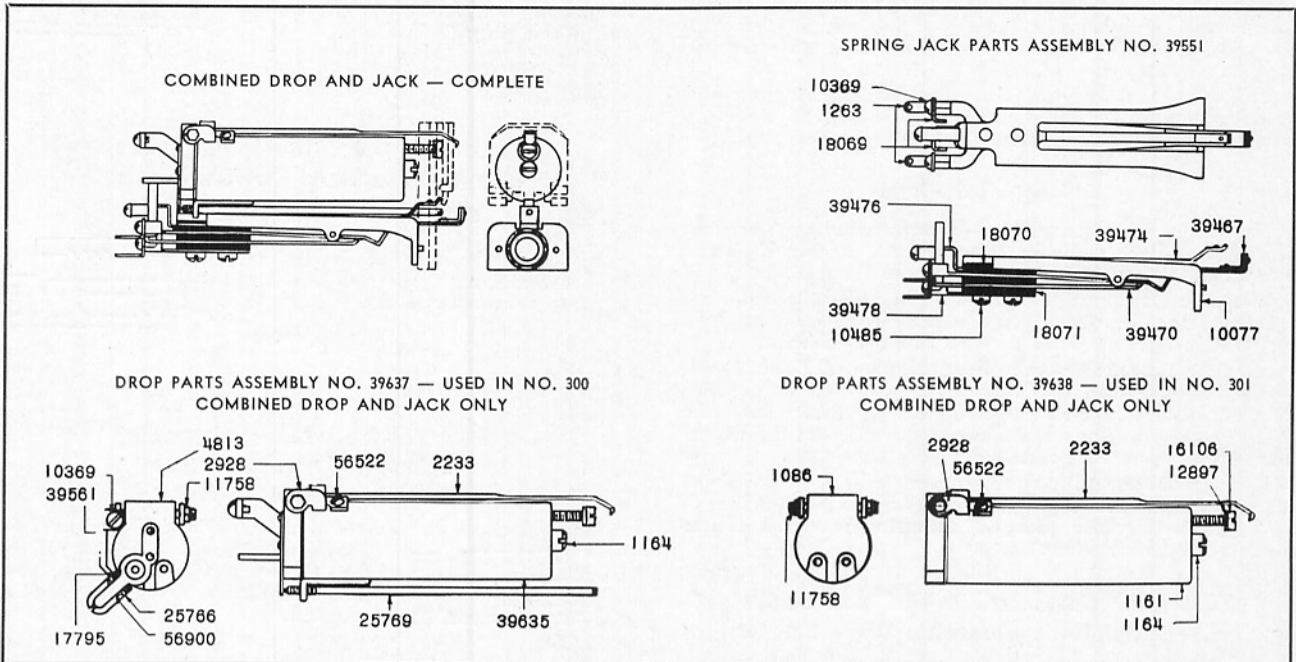

Piece Parts Diagram of Combined Drops and Jacks No. 300 and No. 301.

DROP and JACK MOUNTINGS and CLEAR OUT DROPS

Drop and Jack Mountings

Kellogg mountings for the above drops and jacks are made in strips accommodating five or ten drops and jacks. The strips proper are made of steel, copper plated. Heavy blocks of insulation are used to insulate the drop and the jack from the mounting. The shutters which are furnished are fastened to the mounting. Net weight complete with drops and jacks: five per strip, 2 1/2 lbs.; ten per strip, 4 lbs.

Note: The drop and jack mountings shown here are not shipped equipped with drops and jacks unless so ordered.

Five Per Strip No. 257

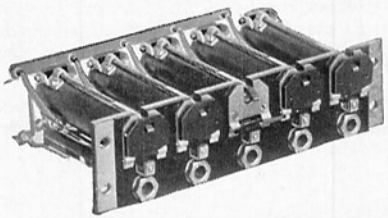

No. 257 mounting, complete with Drops and Jacks installed.

inches and the width of strip is 1 3/4 inches. Weight is 10 ounces.

No. 257 mounting strip is the standard five per strip. It will mount No. 29, 101 and 301 type drops and jacks. The mounting centers are 6 1/4 inches. Length of the face is 5-55/64 inches; overall length is 6-11/16

No. 333

The No. 333 mounting strip is similar to No. 257 but is drilled for code ringing night alarm. Mounts No. 59, 100 and 300 type drops and jacks. Net weight is 10 ounces.

No. 395

The No. 395 is identical to the No. 257 except that two piece No. 28421 adapters are provided to cover the end spacing. This permits flush type mounting. Net weight is 10 ounces. This No. 395 mounting is used with No. 303 drops and jacks.

Ten Per Strip No. 329

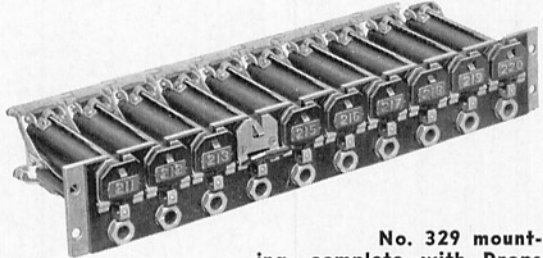

No. 329 mounting, complete with Drops and Jacks installed.

The No. 329 is the standard ten per strip mounting for No. 29, 101 and 301 drops and jacks. Mounting centers are 10-21/32 inches, length of face, 10 1/4 inches and length overall, 11 1/8 inches. Width of the strip is 1 3/4 inches. Net weight is 10 ounces.

Drop and Jack Mountings No. 426

The No. 426 is the standard ten per strip mounting for No. 59, 100 and 300 type drops and jacks. It is similar to the No. 329 except it is drilled for adjustable code ringing night alarm. Net weight is 1 pound.

No. 258

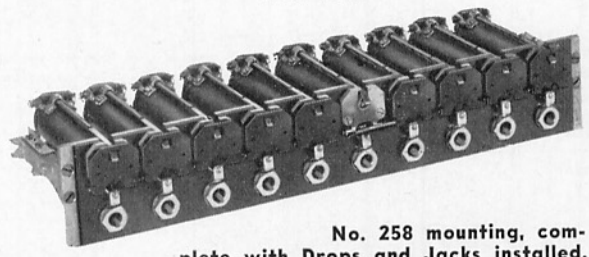

No. 258 mounting, complete with Drops and Jacks installed.

No. 258 is of the lug mounted type and mounts 10 drops and jacks. It may be used to mount type No. 29, 101 and 301 drops and jacks. Width of the strip is 1 7/8 inches, overall length is 10 3/4 inches, length of face is 10 1/4 inches and mounting centers are 11-5/32 inches. Net weight is 1 pound.

Individual Drop and Jack Mounting

One No. 29, 100 or 301 combined drop and jack may be mounted.

Code No.	Dimensions of Face		Mounting Centers
	Height	Width	
306	1 3/4 in.	1 1/2 in.	1 1/4 in.

Individual Clear Out Drop Mounting

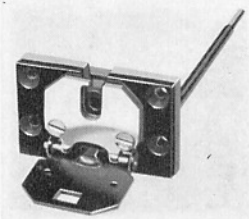

No. 296

One No. 51 clear out drop may be mounted. Mounting centers are 1 1/4 inches and the face of the mounting is 1 inch high and 1 1/2 inches wide.

Clear Out Drops

This Kellogg No. 51 ring off drop or clear out drop is similar in design and embodies all the points of excellence found in the Kellogg line drop. This drop is very sensitive so the shutter is forced to fall with even the weakest ringing current. Drops are of rust-proof construction and are fitted with contacts for night alarm or pilot lamp signals, the same as drops used for the line circuit. Carried in stock in the following resistances:

Code No.	Resistance
51-DC	1000 Ohms
51-DE	500 Ohms

Other resistances can be furnished on special order.

Coils for Clear Out Drops

Standard coils for Kellogg clear out drops are shown below. These coils may be quickly and easily replaced in mountings.

Code No. of Coil	Resistance
DE	500 Ohms
DC	1000 Ohms

Piece parts for Combined Drops and Jack Mountings are shown on page No. 13.

Switchboard Section

SWITCHBOARD APPARATUS

CLEAR OUT DROPS and MOUNTINGS**Mountings for Clear Out Drops**

While a mounting can be furnished to meet practically any requirement, Kellogg recommends using the standard mountings shown below which are carried in stock for prompt shipment. Net weight complete with drops: five per strip, 2½ lbs.; eight per strip, 2¾ lbs.; ten per strip, 3 lbs.

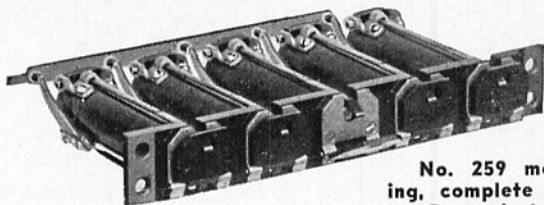
**Five Per Strip
Mounting No. 259**

No. 259 mounting, complete with Drops installed.

The No. 259 drop mounting is standard for mounting five No. 51 drops. In general construction it is similar to the drop and jack mounting strip. The mounting screw centers are 6¼ inches, length of face is 5-27/32 inches and width is 1 inch. The drop mounting centers are 1-3/16 inches. Net weight, 4 ounces.

Mounting No. 449

The No. 449 mounting is the same as No. 259 except the face strip is 1-3/16 inches wide. The face is of the flush type and the strip fits Dean Switchboards.

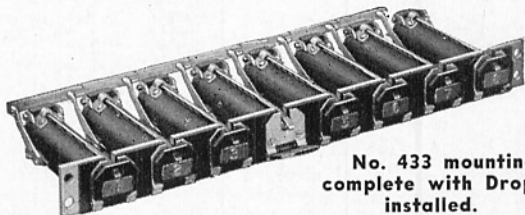
**Eight Per Strip
Mounting No. 433**

No. 433 mounting, complete with Drops installed.

The No. 433 is the standard for mounting eight No. 51 or No. 22 type drops. Overall length is 10-21/32 inches, length of face is 10¼ inches, width is 1 inch and mounting centers, 10-21/32 inches. Drop mounting centers, 1-9/32 inches. Net weight, 10 ounces.

**Ten Per Strip
Mounting No. 427**

The No. 427 drop mounting is similar to the No. 433 and it takes ten drops per strip. Overall length is 10-31/32 inches, mounting centers are 10-21/32 inches, length of face is 10¼ inches and width is 1 inch. Drop mounting centers, 1 inch. Net weight is 12 ounces.

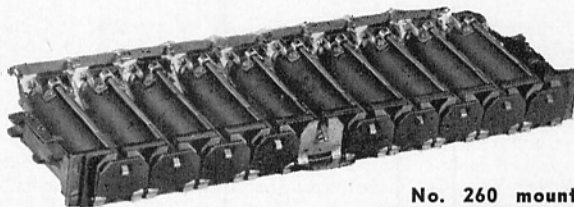
Mounting No. 260

No. 260 mounting, complete with Drops installed.

The No. 260 drop mounting is standard for mounting ten No. 51 drops. It is similar in construction to the drop and jack mounting strip of the lug mounted type. The mounting screw centers are 11-5/32 inches, length of face is 10¼ inches, width of strip is 1 inch and length overall is 10¾ inches. The drop mounting centers are 1 inch. Net weight, 12 ounces.

Note: Other types of mounting strips are available. When ordering send in sample and specify code number and make of switchboard.

Combined Ringer, Drop and Jack**Type No. 3**

The No. 3 type combined ringer, drop and jack is used where a bell signal is required instead of a drop. The gongs are made of nickel plated brass and their diameter is 1-13/32 inches. The nickel plated shutter is operated by the armature clapper and must be restored manually. The jack has the same standard construction as Kellogg combined drops and jacks. Uses plug No. 42.

They are furnished in different resistances as follows:

Code No.	3-A	3-D	3-E
Resistance in Ohms	1000	1600	2500

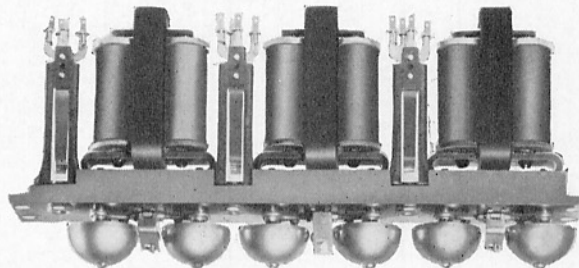
Mountings for Combined Ringer, Drop and Jack**Mounting No. 455**

Code No. 455 mounting takes the same space as the standard ten per strip combined drop and jack mounting. Screw mounting centers are 10-21/32 inches, length of face is 11-3/32 inches and width is 1¾ inches. Mounts three No. 3 type combined ringers and drops.

Piece parts for Clear Out Drop Mountings are shown on page No. 14.

COMBINED DROP and JACK MOUNTINGS--PIECE PARTS

Drop and Jack Mounting No. 257

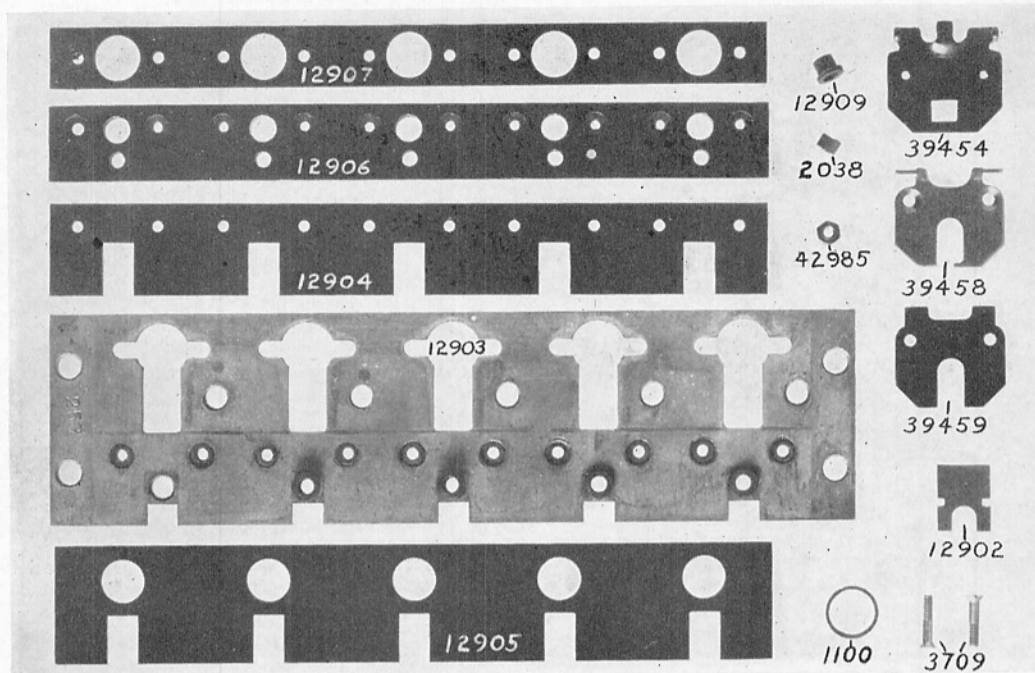

Piece part numbers and a description of each part used in Combined Drop and Jack Mounting No. 257 are listed below along with piece parts used in the other Combined Drop and Jack Mountings.

Mounting No. 257

No. of Pieces	Piece Number	Description
1	12907	Rear Insulation
5	12909	Bushing
5	1100	Bushing
1	4098	Connector Assem.
1	10056	Night Bell Wire
4	12995	Mounting Screw
1	14154	Terminal
4	30336	Terminal
1	12903	Mounting Strip
1	12904	Front Insulation
1	12905	Front Insulation
1	12906	Rear Insulation
5	39459	Shutter Insulation
5	39458	Shutter Support
5	39454	Shutter
10	2038	Bushing
5	12902	Cont. Term. Assem.
10	49285	Shutter Mtg. Nut
10	3709	Shutter Mtg. Screw

Mounting No. 333

Combined drop and jack mounting No. 333 uses the same parts as No. 257 except No. 333 uses No. 25858 front insulation instead of No. 12905.

Mounting No. 395

Combined drop and jack mounting No. 395 uses the same parts as No. 257 except No. 395 uses No. 28739 screws instead of No. 12995 and has two No. 28241 adapters.

Mounting No. 329

Combined drop and jack mountings No. 329 uses the same parts as No. 257 except for the following which apply to No. 329.

No. of Pieces	Piece Number	Description
1	12919	Rear Insulation
1	25927	Mounting Strip
1	12928	Front Insulation
1	12916	Front Insulation
1	12918	Rear Insulation

Mounting No. 426

Combined drop and jack mounting No. 426 uses the same parts as No. 329 except No. 426 uses one No. 8955 terminal in addition to those shown for No. 329 and that No. 426 uses No. 29350 front insulation instead of No. 12928.

Mounting No. 258

Combined drop and jack mounting No. 258 uses the same parts as No. 257 except for the following parts which apply to No. 258.

No. of Pieces	Piece Number	Description
1	12918	Rear Insulation
1	9304	End Lug Assem. L.
1	9305	End Lug Assem. R.
4	42033	Screw
1	12915	Mounting Strip
1	12916	Front Insulation
1	12917	Front Insulation
1	12918	Rear Insulation

Switchboard Section

SWITCHBOARD APPARATUS

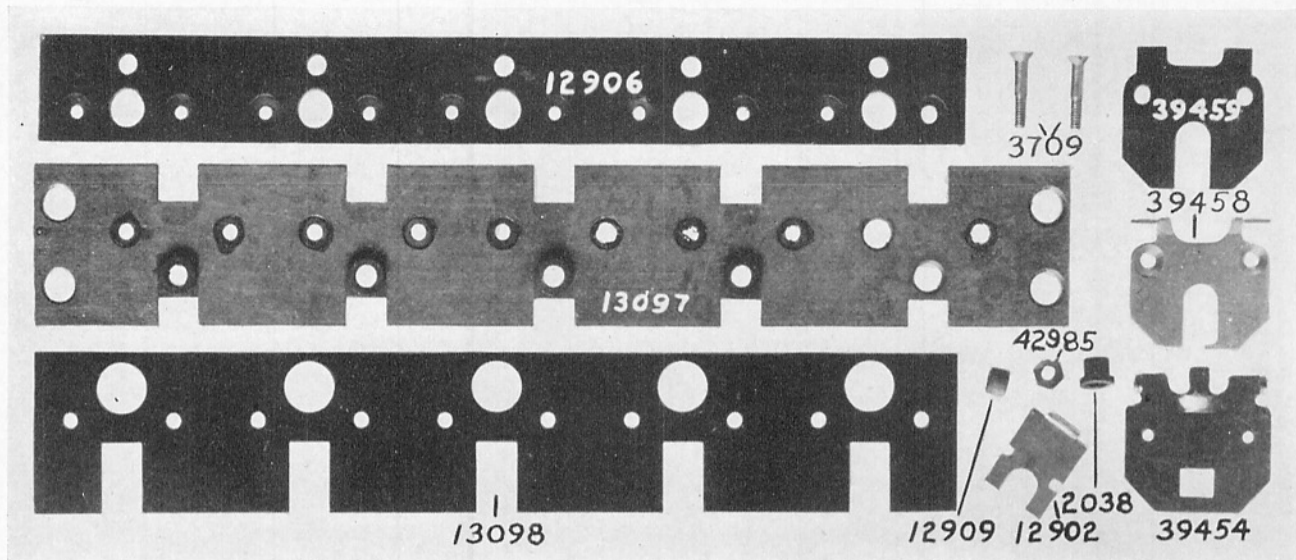
MOUNTINGS for CLEAR OUT DROPS -- PIECE PARTS**Drop Mounting No. 259**

Piece part numbers and a description of each part used in Clear Out Drop Mounting No. 259 are listed below along with piece parts used in the other Mountings for Clear Out Drops.

Mounting No. 259

No. of Pieces	Piece Number	Description
1	13097	Steel Mtg. Strip
1	13098	Front Insulation
1	12906	Rear Insulation
5	39459	Shutter Insulation
5	39458	Shutter Support
5	39454	Shutter
10	2038	Bushing
5	12909	Bushing
5	12902	Cont. Term. Assem.
1	4098	Connector Assem.
1	12996	Night Bell Wire
1	14154	Terminal
4	30336	Terminal
10	3709	Shutter Mtg. Screw
10	42985	Shutter Mtg. Nut
4	12995	Mounting Screw

Mounting No. 433

No. of Pieces	Piece Number	Description
1	30967	Steel Mtg. Strip
4	12995	Mounting Screw
1	25015	Front Insulation
1	25013	Rear Insulation
8	39459	Shutter Insulation
8	39458	Shutter Support
8	39454	Shutter
16	2038	Bushing
8	12909	Bushing
8	12902	Cont. Term. Assem.
16	42985	Nut
1	8955	Night Bell Wire
1	14154	Terminal
7	30336	Terminal
16	3709	Screw

Mounting No. 426

No. of Pieces	Piece Number	Description
1	30205	Mounting Strip
4	12995	Mounting Screw
1	13109	Front Insulation
1	12918	Rear Insulation
10	39459	Shutter Insulation
10	39458	Shutter Support
10	39454	Shutter
20	2038	Bushing
10	12909	Bushing
10	12902	Cont. Term. Assem.
1	14154	Terminal
9	30336	Terminal
1	8955	Night Bell Wire
20	3709	Screw
20	42985	Nut

Mounting No. 260

No. of Pieces	Piece Number	Description
1	13102	Steel Mtg. Strip
1	9304	End Lug Assem. L
1	9305	End Lug Assem. R
4	42033	Mounting Screw
1	13103	Front Insulation
1	12918	Rear Insulation
10	39459	Shutter Insulation
10	39458	Shutter Support
10	39454	Shutter
20	2038	Bushing
10	12909	Bushing
10	12902	Cont. Term. Assem.
1	14154	Terminal
9	30336	Terminal
1	8955	Night Bell Wire
20	3709	Screw
20	42985	Nut

SPRING JACKS

Kellogg spring jacks are designed to withstand severe use with a minimum of wear on the springs and on the plugs that are used with them.

The frame of these jacks is of heavy, rigid brass construction with phenol fibre insulation. Mounting strips are made of the finest grade of hard rubber. The German silver springs are properly tempered to withstand the hard usage to which they are subjected and to give maximum life.

Two Conductor For Plugs Nos. 42, 55 and 137

Diameter, .2495 in.

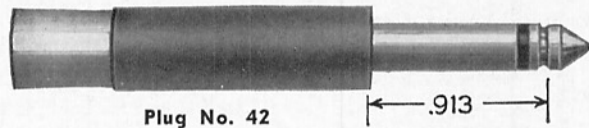

Plug No. 42

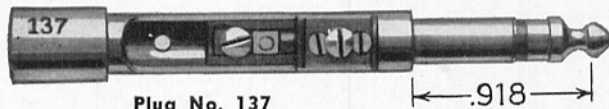

Plug No. 137

Twenty Spring Jacks per Strip No. 116

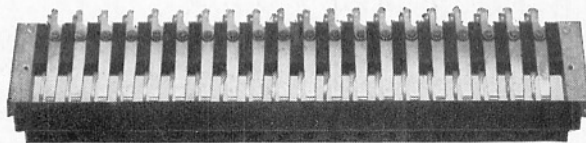

The face of the No. 116 strip of spring jacks is 10 1/4 inches long and 7/16 inch high. Strip mounting centers are 11-5/32 inches and the jacks are on 1/2 inch centers.

Code No.	Spring Combination	Description
116		2-Conductor

Ten Spring Jacks per Strip No. 195

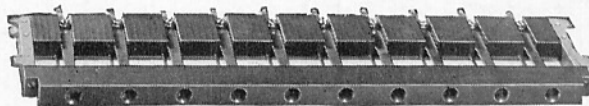

The face of the No. 195 strip of jacks is 10 1/4 inches long and 7/16 inch high. Mounting pins are on 11-5/32 inch centers and jacks are on 1 inch centers.

Code No.	Spring Combination	Description
195		Slotted for number plate. Lines up with No. 8-L lamp jack.

No. 186

The face strip dimensions are 10 1/4 x 1/2 inches. Strip mounting centers are 11-5/32 inches. The jacks mount on 1 inch centers.

Code No.	Spring Combination	Description
186		5 jacks same as No. 129 and 5 jacks same as No. 132.

For convenience the jacks are arranged according to the plug types they fit. If in doubt or if the jacks listed do not meet your requirements please send complete specifications and the Kellogg engineering department will promptly submit their recommendations.

Note: Operator's jacks are listed with operator's plugs on Page No. 20.

Two Conductor — For Plugs No. 42, 55 and 137 Individual Spring Jacks Nos. 85 and 277

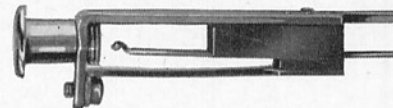

Code No. Spring Combination

85

277

1 Make and Break.

The overall length of the No. 85 and 277 jacks is 3 inches. Mountings are on 5/8 inch centers.

Description
Mounts on 31/64 inch panel.
Mounts on 33/64 inch panel.

No. 319

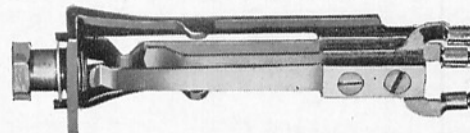

The overall length of jack No. 319 is 3 3/4 inches. Mountings are on 5/8 inch centers. Mounts on 9/32 inch panel.

Code No.	Spring Combination	Description
319		1 Conductor Has restoring spring cut-off.

Three Conductor For Plug No. 201

Diameter .2215 in.

Twenty Spring Jacks per Strip Nos. 239 and 257

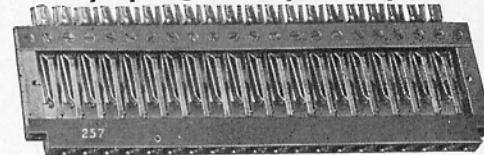

The face of the No. 239 and 257 strips of jacks are 7-21/32 inches long and 3/8 inch

high. Strip mountings are on 8-9/32 inch centers and jacks are on 1/2 inch centers. Replaced by 367 and 369 shown below.

Code No.	Spring Combination	Description
239		
257		Same as No. 239 except drilled for party line indicators.

Nos. 367 and 369

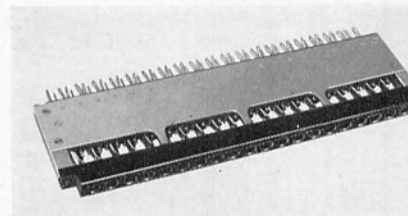

The face strip dimensions are 7-21/32 x 3/8 inches. Strip mounting centers are 8-9/32 inches and the jacks mount on 1/2 inch centers. These strips of

jacks are inverted so that the brass retaining strip is employed as a dust protector for the spring assemblies.

Code No.	Spring Combination	Description
367		Same as No. 257 but inverted. Drilled for party line indicators.
369		Same as No. 239 but inverted.

Switchboard Section

SWITCHBOARD APPARATUS

SPRING JACKS

Three Conductor — Fits Plug No. 201

Twenty Spring Jacks per Strip — Continued

No. 292

The face strip dimensions are 7-49/64 x 3/8 inches. Strip mounting centers are 8-41/64 inches and the jacks mount on 1/2 inch centers.

Code No.	Spring Combination	Description
292		Drilled for party line indicators.

Ten Spring Jacks per Strip

Nos. 274 and 253

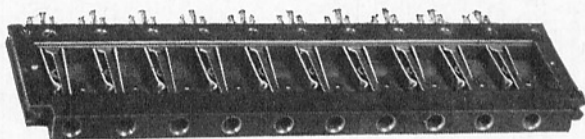

The faces of No. 253 and 274 strips of jacks are 7-21/32 inches long and 3/8 inch high. Strip mounting centers are 8-9/32 inch and jacks are on 1 inch centers.

Code No.	Spring Combination	Description
274		Same as No. 274 but slotted for number plates.
253		

Three Conductor — For Plug No. 106

Diameter, .2495 in.

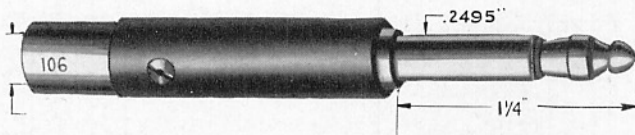

Twenty Spring Jacks per Strip

Nos. 261, 258, 268, 270 and 272

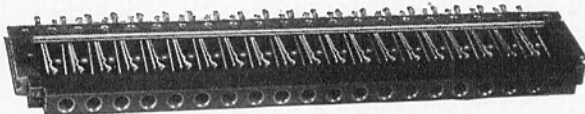

The faces of these strips of jacks are 10 1/4 inches long and 7/16 inch high. Strip mounting centers are 11-5/32 inches and jacks are on 1/2 inch centers.

Code No.	Spring Combination	Description
261		Drilled for party line indicators.
258		
268	2-Conductor Contacts.	Same as No. 267 but twenty per strip.
270	1 Make Contact.	Same as No. 269 but twenty per strip.
272	1 Break Contact.	Same as No. 271 but twenty per strip.

Three Conductor — Fits Plug No. 106

Ten Spring Jacks per Strip

Nos. 273, 259, 267, 354, 271 and 269

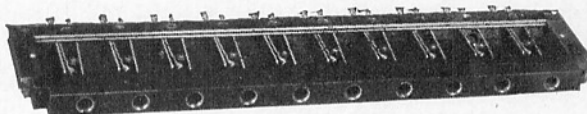

The faces of these strips of jacks are 10 1/4 inches long and 7/16 inch high. Strip mounting centers are 11-5/32 inches and jacks are on 1 inch centers.

Code No.	Spring Combination	Description
273		Slotted for number plate.
259		
267		Same as No. 268 but 10 per strip.
354	2-Conductor Contacts.	Same as No. 267 but drilled for party line indicators.
271	1 Break Contact.	Same as No. 272 but 10 per strip.
269	1 Make Contact.	

Five Spring Jacks per Strip

Nos. 297, 296 and 318

The faces of these strips of jacks are 10 1/4 inches long and 7/16 inch high. Strip mounting centers are 11-5/32 inches and jacks are on 2 inch centers.

Code No.	Spring Combination	Description
297		Same as No. 273 but five per strip.
296	2-Conductor Contacts.	Same as No. 267 but five per strip.
318	1 Make Contact.	Same as No. 269 but five per strip.

Individual Spring Jacks Nos. 260, 286 and 256

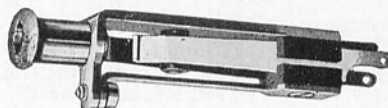

The overall length of these jacks is 3 inches. They mount on 3/8 inch centers.

Code No.	Spring Combination	Description
260		Test jack, mounts on 9/16 inch panel.
286	1 Make and Break.	Mounts on 1/2 inch panel. Fits W. E. plug No. 110 on 3/8 inch panel.
356	1-Conductor Contact.	

SPRING JACKS

**Three Conductor
For Plugs Nos. 44, 70 and 152**



**Twenty Spring Jacks per Strip
No. 146**

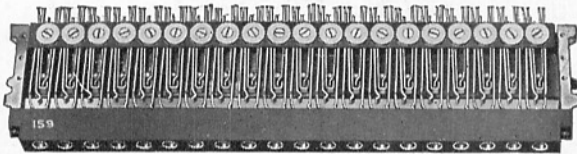

The face of the No. 146 strip of jacks is 10 1/4 inches long and 1/2 inch high. Strip mounting centers are 11-5/32 inches and jacks are on 1/2 inch centers.

Code No.	Spring Combination	Description
146		

**Ten Spring Jacks per Strip
Nos. 141 and 191**

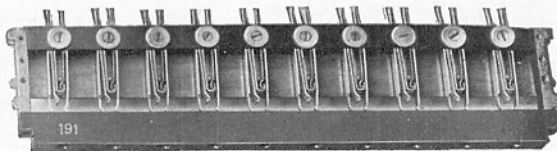

The faces of these strips of jacks are 10 1/4 inches long and 1/2 inch high. Strip mounting centers are 11-5/32 inches and jacks are on 1 inch centers.

Code No.	Spring Combination	Description
141		
191		1 Make Contact.

**Individual Spring Jacks — Fit Plugs
No. 70, 152 and 230**

No. 361

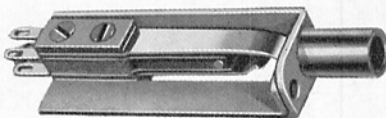

No. 361 spring jack mounts on 5/8 inch centers. It is used with mountings No. 361 and 600.

Code No.	Spring Combination	Description
361		2-Conductor Contacts. Mounts on 9/16 inch panel.

No. 371

Mounts on 5/8 inch centers. Jack No. 371 is similar in appearance to No. 361 shown above.

Code No.	Spring Combination	Description
371		Less restoring spring.

**Two Conductor
For Plugs Nos. 44, 70 and 152**

Individual Spring Jacks

No. 298

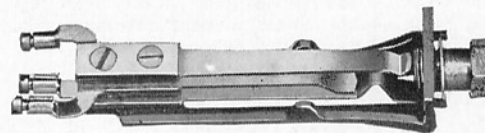

The overall length of jack No. 298 is 3 3/4 inches. It mounts on 5/8 inch centers.

Code No.	Spring Combination	Description
298		2-Conductor Contacts. Less restoring spring.

Nos. 360 and 362

The overall length of jacks No. 360 and 362 is 3 3/8 inches. They mount on 5/8 inch centers. Similar in appearance to No. 361 shown in left hand column.

Code No.	Spring Combination	Description
360		Mounts on 9/16 inch panel.
362		Fits W. E. jack No. 223-A. Mounts on No. 604 strip.

Nos. 357 and 366

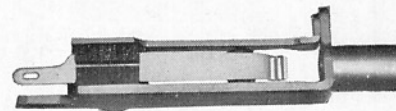

Jacks No. 357 mounts on 9/16 inch centers and No. 366 mounts on 5/8 inch centers.

Code No.	Spring Combination	Description
357		Mounts on a 9/16 inch panel.
366		1 Break Contact. Replaces W. E. No. 237-A jack. Fits W. E. No. 47 plug and Kellogg No. 247 plug.

Nos. 363 and 364

The overall length of jacks No. 363 and 364 is 3-7/16 inches. They mount on 5/8 inch centers, and require a mounting space of 3/4 x 1/2 inch. These jacks are similar in appearance to jack No. 361.

Code No.	Spring Combination	Description
363		2-Conductor Contacts. Mounts on No. 604 and 603 strips. Replaces W. E. No. 218-A jack.
364		1-Conductor Contact.

No. 434 Jack Mounting



The No. 434 jack mounting mounts ten No. 319 individual spring jacks. It is a steel strip 1 inch wide and 10 1/4 inches long and its mounting centers are 10-21/32 inches. The jacks mount on 1 inch centers.

Switchboard Section

SWITCHBOARD APPARATUS

PLUGS

Kellogg switchboard plugs are made to give maximum service. The heavy brass tips resist wear, and the hard rubber insulation will not break down even after years of severe usage.

Every part carefully made to eliminate plug breakage. Connections are protected by fibre sleeve held securely in place.

Note: Whit. is the abbreviation for Whitworth tap having rounded top threads which prevent cutting cords.

Two Conductor Plugs For Kellogg Jacks No. 42 Plug

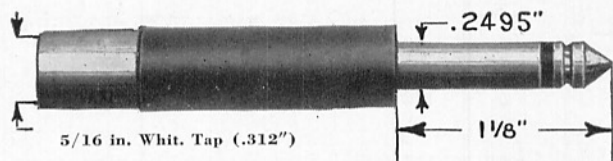

No. 42 is the standard two conductor plug used on practically all self restoring type drops and jacks. It fits cords No. 301-TO and 304-ST. No. 42 plug is used with No. 300 and 301 type drop and jacks.

No. 187 Plug

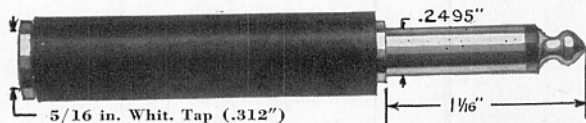

The tip conductor of plug No. 187 is specially arranged to fit spring jacks with tip springs varying in location. It is used for old type two wire multiple jacks and fits cords No. 301-TO and 304-ST.

No. 109 Plug

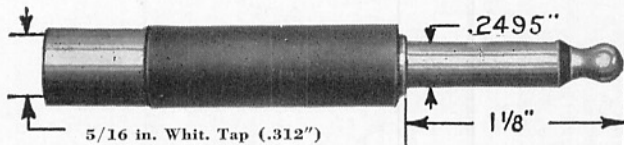

The No. 109 two conductor plug will operate three conductor jacks of plug group No. 152. It fits cords No. 301-TO and 304-ST.

For Jacks of Other Makes No. 247 Plug

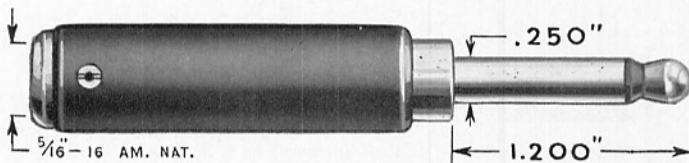

No. 247 plug replaces W. E. No. 47. It fits cords No. 397-TO and 304-ST.

Two Conductor, For Jacks of Other Makes No. 144 Plug

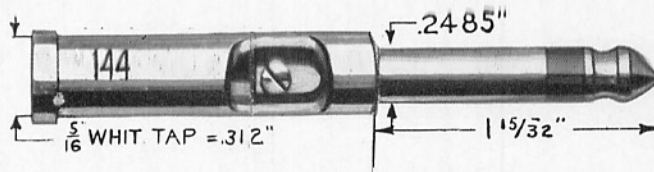

Plug No. 144 replaces Swedish American plugs and fits cords No. 331-ST.

No. 255 Plug

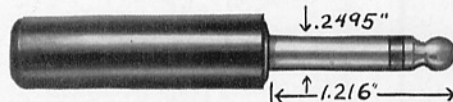

No. 255 plug has an overall sleeve. Aside from this it is similar to Kellogg plug No. 247 and W. E. plug No. 47.

Three Conductor Plugs For Kellogg Jacks No. 201 Plug

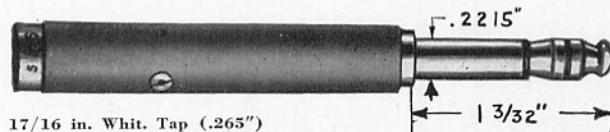

No. 201 is the standard three conductor plug for small diameter jacks. It fits cords No. 326-TO and 325-ST.

No. 106 Plug

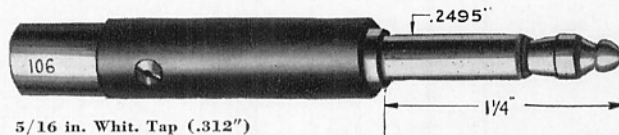

No. 106 plug is used on common battery and magneto multiple and non-multiple boards. It has provision for non-short circuiting when placing plug in jack and fits cords No. 309-TO and 303-ST. No. 106 is the standard three conductor plug for 1/4 inch jacks.

No. 152 Plug

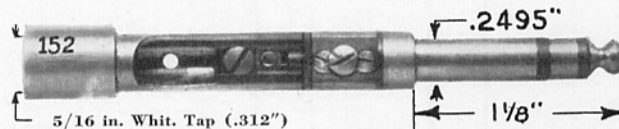

Use cords No. 309-TO and 303-ST with the No. 152 plug.

No. 137 Plug

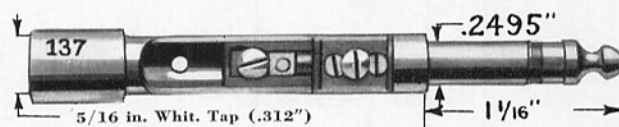

No. 137 is a three conductor plug that will fit two conductor jacks of plug group No. 152. It fits cords No. 309-TO and 303-ST.

PLUGS and PLUG SEATS

Switchboard Plugs — Three Conductor For Jacks of Other Makes

No. 233 Plug

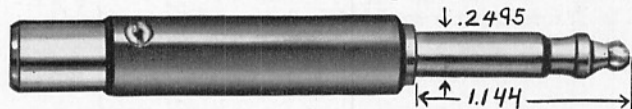

Plug No. 233 replaces W. E. plug No. 110.

No. 185 Plug



Plug No. 185 replaces W. E. plug No. 109. Switchboard cord No. 390-TO may be used with this plug.

No. 235 Plug

Plug No. 235 replaces S. C. plug No. 53-X. It has a diameter of .2495 in. and the length from the tip to the sleeve is .1089 inches.

No. 268 Plug

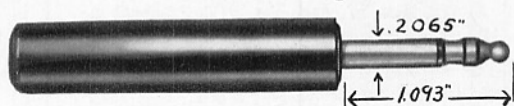

No. 268 plug has an overall sleeve. Aside from this it is similar to Kellogg plug No. 185 and W. E. plug No. 109.

Dummy Plugs



Dummy plugs are used for designating lines in trouble, service discontinued, etc. They are available in two sizes for jacks taking plugs of the diameter shown and are made of brass, finished with enamel in the colors shown below. They fit all 1/4 inch diameter jacks.

Code No.	Diameter of Plug, Inches	Color	Code No.	Diameter of Plug, Inches	Color
83	.2495	White	93	.219	White
84	.2495	Black	94	.219	Black
85	.2495	Red	95	.219	Red
86	.2495	Blue	96	.219	Blue
87	.2495	Yellow	97	.219	Yellow
88	.2495	Green	98	.219	Green

No. 24



No. 24 dummy plugs are made of polished, hard rubber. The length of the plug is 1 1/8 inches and the diameter is .2495 inch.

No. 133-B Lamp Hole Blanks

No. 133 lamp hole blanks are the same as No. 134-B plug hole blanks except diameter of the plug is .333 inch, and the total length is 1-15/64 inches.

Plug Seats

Plug seats in strips cannot be accurately drilled unless they are fitted to the plug shelf and drillings made with the old plug holes as a guide. Strips are shipped undrilled and if desired, necessary tools for drilling are furnished.

Individual Plug Seats No. 9



The No. 9 individual plug seat consists of two parts, a leather washer and a red fibre seat, which may be fastened to the plug shelf by 2 wood screws which are furnished. The leather washer is 5/32 inch thick and has an outside diameter of 11/16 inch. The dimensions of the 1/8 inch red fibre strip are 1 by 3/4 inch. The cord hole is .368 inch in diameter.

No. 10

No. 10 individual plug seat is similar to No. 9. It consists of a red fibre washer and a brass seat which may be fastened to the plug shelf by two wood screws which are furnished. The 1/8 inch red fibre washer has an outside diameter of 11/16 inch. The brass strip is 1 by 3/4 inch. The cord hole is .368 inch in diameter.

Plug Seats — Strip Type



Plug seat strips are furnished in two sizes and with-

out cord hole drilling. Tool sets for drilling, reaming and burnishing to assure line up after strips are mounted in position are shown below.

Code No.	Length	Width	Thickness
15	19 3/8 in.	2 1/8 in.	1/8 in.
25	21 3/8 in.	2 1/8 in.	1/8 in.

Tool Kits For Drilling Plug Seats

Code No.	Description
65	For drilling No. 42 and 106 plug seats.
66	For drilling No. 201 plug seat.

Trouble Sleeves

Trouble sleeves are made of fibre tubing and are used for designating defective cords and plugs. The tubing is split to allow for variation in plug diameters. They are furnished in two sizes.

Code No.	Description
163	For plugs .2495 inch in diameter.
223	For plugs .2215 inch in diameter.



No. 134-B Plug Hole Blanks

No. 134-B dummy plug is made of maple with a black ebony-finished top. It is used with the Kellogg standard plug bushing No. 19222. The diameter of the plug is .484 inches, and the length is 1-39/64 inches.

Plug blanks can be furnished in other sizes and finishes upon request.

Switchboard Section

SWITCHBOARD APPARATUS

OPERATORS' PLUGS and JACKS

Two Conductor

No. 75 and No. 107 Plugs and No. 24 Jack

No. 107 Plug

The construction of No. 107 plug is similar to that of a standard switchboard plug. It is used with No. 24 jack. It fits No. 708-OR cord.

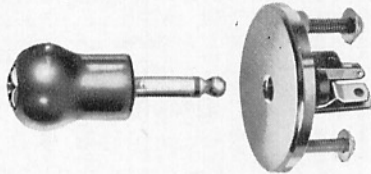

No. 107 Plug No. 24 Jack

No. 75 Plug

No. 75 plug is identical to 107 except that it is provided with piece No. 13034 bushing to take a smaller diameter cord. It is used with No. 24 jack. No. 237-OR cord may be used with this plug.

No. 24 Jack

Jack No. 24 mounts from the rear with machine screws. The face has a diameter of 1 7/8 inches. It is used with the No. 75 or No. 107 plug.

Code No. of Jack	Spring Combination	Fits Plug No.	Description
24		75 107	Brass, nickel plated.

Four Conductor

No. 182 and No. 245 Plugs and No. 325-A Jack

No. 182 Plug

No. 182 plug is the standard operator's plug used in Kellogg switchboards equipped with the breast-plate type operator's set. It is with No. 325-A jack, No. 722-O or 713-O cords may be used with this plug.

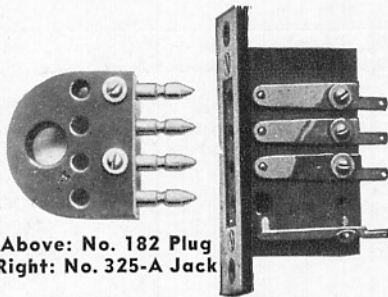

Above: No. 182 Plug
Right: No. 325-A Jack

No. 245 Plug

No. 245 plug replaces S. C. No. 23 plug. It is used with No. 325-A jack.

No. 325-A Jack

This jack has a black fibre frame and mounts on 7/16 inch centers with mounting No. 452.

Code No.	Spring Combination	Fits Plug No.	Description
325-A		182 245	Metal escutcheon

No. 145 Plug and No. 43 Jack

No. 145 Plug

The prongs of plug No. 145 are mounted in a hard fibre strip which is provided with terminal screws, conductor separators and an adjustable strip to grip the cord and prevent any strain on the terminal connections. It is used with No. 43 jack. No. 721-O and 711-O cords may be used with this plug.

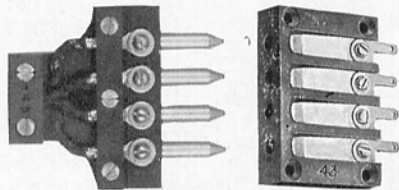

No. 145 Plug No. 43 Jack

Four Conductor — Cont.

No. 43 Jack

The face plate of this jack is 2 1/4 x 1/2 inch in size. The frame mounts on 7/16 inch centers.

Code No.	Spring Combination	Fits Plug	Description
43		145	Hard rubber frame

No. 25 and No. 136 Plugs and No. 57 and No. 224 Jacks

No. 25 Plug

No. 25 consists of two plugs under one cover. It is used with No. 57 jack. No. 712-O cord may be used with this plug.

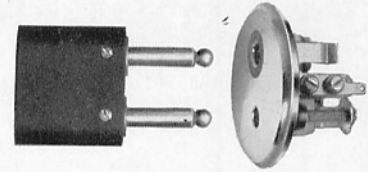

No. 25 Plug No. 57 Jack

No. 136 Plug

No. 136 plug is identical to No. 25 except it is provided with bushing No. 28818 to take a smaller diameter cord. It is used with No. 57 jack.

No. 57 and No. 224 Jacks

Jacks No. 57 and 224 are nicked brass and mount from the rear with machine screws. They are used with breastplate type transmitters.

Code No.	Spring Combination	Fits Plug	Size Face of Strip
57		25 136	2 in. diameter
224		25 136	2 in. diameter

No. 139 Plug and No. 310 Jack

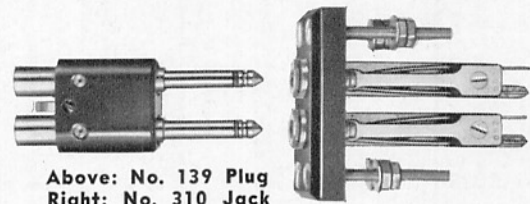

Above: No. 139 Plug
Right: No. 310 Jack

No. 310 Jack

Jack No. 310 consists of two No. 260 individual spring jacks mounted on hard rubber.

Code No.	Spring Combination	Fits Plug	Size Face of Strip
310		139	2-11/32 x 1 1/4 in.

No. 139 Plug

No. 139 plug consists of two No. 130 plugs under one cover. It is used with Kellogg No. 310 jack. It replaces W. E. plug No. 137 and 152 and fits W. E. Jack No. 99. No. 466-OR and 709-O cords may be used with this plug.

Kellogg

TUNGSTEN FILAMENT SWITCHBOARD LAMPS

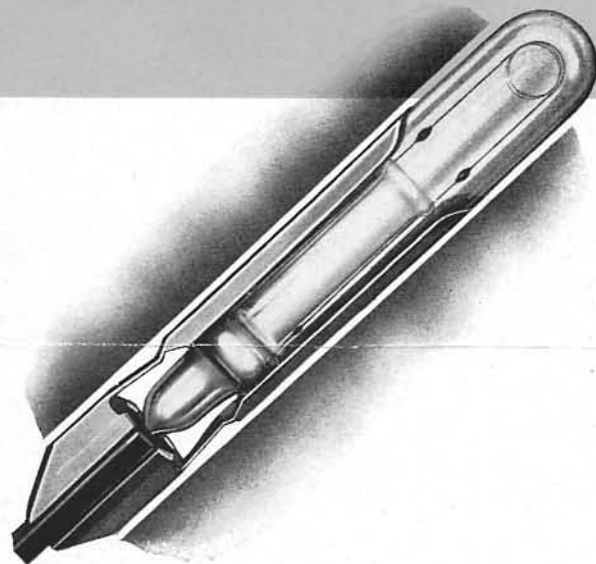

THE chart below provides an extremely simple, easy method of determining the exact lamp to use for each specific application in both 24 and 48 volt switchboards. This standardization of lamps, based on their application, is the result of Kellogg's thorough study of general switchboard lamp requirements.

Because of broad experience gained in over 46 years of designing, engineering and manufacturing telephone systems, Kellogg is able to provide this standardization table involving but a few types of lamps to fit all switchboard requirements.

Built for Long Life, Economy and Superior Performance

These switchboard lamps are manufactured in Kellogg's own lamp department by skilled workers with highly developed machinery, specifically designed for the job.

Extreme care is used to make sure that the glass is of uniform thickness and texture and is shaped without a tip so as to concentrate the light at the proper point. The terminals strengthen and protect the lamp as well as make perfect contact when placed in the jack. The phenol fibre separator, the glass support for the specially prepared filament and the almost perfect vacuum are other features built into Kellogg switchboard lamps to insure long life, economy and superior performance.

Kellogg lamps are uniform in size, in current consumption, in brilliance. They fit standard lamp jacks in switchboards of all makes. Overall length 1 11/16 inches, diameter, 5/16 inch.

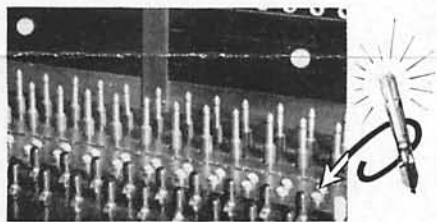

Use the Chart for Easy Ordering

To determine the proper lamp to use, first select the type of lamp needed in the "use" column. The code number of the lamp to order is then given in the adjoining column. In ordering Kellogg lamps for replacement, give the code number and make of the lamp now being used.

NOTE: A slight spring adjustment may be necessary on pilot relays if they do not operate satisfactorily when type TD lamps are installed. This can be done by reducing spring tension and armature travel on your present pilot relays.

Use	Code No.	Current Consumption at Maximum Voltage		Approx. Cold Resistance
		Minimum Amperes	Maximum Amperes	
For 24 Volt Telephone Systems				
Line, Cord, Pilot and Trunk Lamps for Common Battery Multiple or Non-Multiple Swbds.	1632-TD	.035	.045	80
Busy Lamps for Common Battery Multiple Swbds.*	2448-TD	.025	.035	122
Busy Lamps for Common Battery Multiple Swbds. (Lamps covered by designation strips)	2040-TD	.028	.038	100
Line, Cord, Pilot and Trunk Lamps for PBX Switchboards	1224-TD	.040	.055	60
Annunciator Systems	1224-TA	.085	.115	24
*If other than a red lamp cap or if a type 254 lamp cap is used order Lamp No. 1632-TD.				
For 48 Volt Telephone Systems				
Line, Cord, Pilot and Trunk Lamps for Common Battery Multiple or Non-Multiple Swbds.	2448-TD	.035	.050	122
Busy Lamps for Common Battery Multiple Swbds.	4896-TD	.028	.038	240
Annunciator	2448-TA	.045	.060	92

KELLOGG SWITCHBOARD AND SUPPLY COMPANY
 Factory and General Offices: 6650 S. CICERO AVE., CHICAGO, ILL., U. S. A.

SWITCHBOARD LAMPS and LAMP CAPS

Switchboard Lamps

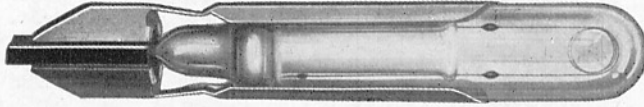

Kellogg switchboard lamps are manufactured by skilled workmen with highly perfected machinery, specifically designed for the job, Kellogg lamps are the best obtainable. Uniform size, current consumption, and brilliancy are assured. Kellogg lamps will fit all standard lamp jacks.

Extreme care is used to make sure that the glass is of uniform thickness and texture and is shaped without a tip so as to concentrate the light at the proper point. The brass contact terminals give strength and protection to the lamp as well as perfect contact when placed in the jack. The phenol fibre separator, the glass support for the filament, the specially prepared filament, the almost perfect vacuum produced by the mercury air exhausting pumps, and many other features insure a switchboard lamp of long life and superiority to any other lamp now on the market.

Tungsten or Carbon Filaments

Both carbon and tungsten filament lamps are available. Tungsten has greater brilliance and gives more satisfactory illumination over a wider voltage range than do carbon lamps. Carbon lamps, however, in certain cases meet circuit requirements that tungsten lamps do not. For instance, in certain types of circuits a momentary current is carried to the lamps when a signal actually is not intended. Tungsten lamps will light up briefly under such a condition and signal the operator. Carbon lamps on the other hand will not glow as quickly and consequently will not light up from a brief impulse of current.

Users of Kellogg switchboard lamps are assured uniformity, reliability and lowest cost per year of service.

Overall length is 1-11/16 inches, diameter overall is 5/16 inch. The following voltages are carried in stock:

Code Numbers	Voltage	Current Minimum Amperes	Consumption Maximum Amperes
Carbon			
3-A	3	.200	.260
4-A	4	.170	.210
6-A	6	.120	.160
6-B	6	.300	.380
6-C	6	.170	.210
8-A	8	.085	.115
10-A	10	.085	.115
12-A	12	.085	.115
12-C	12	.025	.035
14-A	14	.085	.115
16-A	16	.085	.115
18-A	14 to 26*	.035	.045
20-A	20	.085	.115
24-A	24	.075	.115
....	24	.085	.115
24-C	24	.025	.035
27-A	27	.085	.115
30-A	30	.080	.115
32-A	27 to 36**	.025	.035
36-A	36	.060	.080
40-A	40	.045	.060
40-B	35 to 47***	.025	.0375
44-A	44	.045	.060
48-A	48	.045	.060
55-A	55	.045	.060
Tungsten			
3-TA	3	.200	.260
4-TA	4	.170	.210
6-TA	6	.120	.160
6-TB	6	.300	.380
6-TC	6	.170	.210
8-TA	8	.085	.115
10-TA	10	.085	.115
12-TA	12	.085	.115
12-TC	12	.025	.035
14-TA	14	.085	.115
16-TA	16	.085	.115
18-A	14 to 26*	.035	.045
20-TA	20	.085	.115
24-A	24	.075	.115
....	24	.085	.115
24-TC	24	.025	.035
27-A	27	.085	.115
30-TA	30	.080	.115
32-A	27 to 36**	.025	.035
36-TA	36	.060	.080
40-TA	40	.045	.060
40-B	35 to 47***	.025	.0375
44-TA	44	.045	.060
48-TA	48	.045	.060
55-A	55	.045	.060

* Current limits shown are with 18 volts on lamp.

** Current limits shown are with 32 volts on lamp.

*** Current limits shown are with 40 volts on lamp.

Standard Mazda Lamps

This standard mazda lamp with an Edison base is used in ringing circuits.

Code No.	Volts	Watts
110-A	110	15

Switchboard Lamp Caps Type No. 154

Type No. 154 lamp caps fit 11/32 inch holes. The lacquered brass shanks are 9/32 inch long. This cap is used with Nos. 25, 31, 32, 33, 34, 37, 43, and 44 types of lamp jacks. Specify numbering desired on No. 154-C.



No. 154	No. 154-D	No. 154-F	No. 154-G	No. 154-U
Code No.	Marking	Color	Shape of Lens	Description
154	○	White Opalescent	Convex	Groove for extractor
154-A	○	Clear Red Glass	Convex	Back of lens ground
154-B	○	Clear Green Glass	Convex	Back of lens ground
154-C	⊙	Clear Glass	Semi-Convex	Arranged for numbering
154-F	○	Clear Glass	Semi-Convex	
154-G	○	White Opalescent	Flat Lens	
154-D	⊕	White Opalescent	Convex	Marked with black enamel
154-II	⊖	White Opalescent	Convex	Marked with black enamel
154-J	⊙	White Opalescent	Convex	Marked with black enamel
154-K	⊕	White Opalescent	Convex	Marked with black enamel
154-L	⊙	White Opalescent	Convex	Marked with black enamel
154-M	⊖	White Opalescent	Convex	Marked with black enamel
154-U	○	Clear Red Glass	Semi-Convex	Back of lens ground
154-V	○	Clear Green Glass	Semi-Convex	Back of lens ground
154-W	○	Clear Green Glass	Convex	Back of lens ground, front sand blasted
154-N	○	Blue Opalescent	Convex	
154-R	○	Green Opalescent	Convex	Green lacquer on back
154-P	○	Clear Red Glass	Convex	Back of lens ground, front sand blasted
154-Q	○	Clear Green Glass	Convex	Back of lens ground, front sand blasted



Type No. 79

Type No. 79 lamp caps fit 5/16 inch holes and the shanks are 1/2 inch long. These caps are used with Nos. 35, 36, and 41 types of lamp jacks.

Code No.	Marking	Color	Shape of Lens	Description
79	○	White Opalescent	Convex	
79-A	○	Clear Red Glass	Convex	Back of lens ground
79-E	⊕	White Opalescent	Convex	
79-F	⊖	White Opalescent	Convex	
79-G	○	Clear Green Glass	Convex	Back of lens ground,
79-K	⊙	Clear Green Glass	Convex	Marked with white enamel, Back of lens ground
79-L	⊖	White Opalescent	Convex	Marked with black enamel
79-M	⊕	Red Opalescent	Convex	Marked with white enamel

Switchboard Section

SWITCHBOARD APPARATUS

LAMP CAPS and LAMP JACKS

Switchboard Lamp Caps

Type No. 25



Type No. 25 lamp caps fit 11/32 inch holes. The shanks are 5/16 inch long. They are used with No. 23 lamp jacks and other jacks with hard rubber face strips. This cap screws on and is provided with blank paper discs for numbering.

Code No.	Marking	Color	Shape of Lens	Material
25	○	Red	Disc	Celluloid
27	○	White	Disc	Celluloid



Type No. 9

Type No. 9 lamp caps fit 19/32 inch holes. The nickel plated shank is 7/16 inch long. This cap is used generally for pilot and signal work.

Code No.	Color	Face of Lens	Description
9	White Opalescent	Diamond	
9-A	Clear Red Glass	Diamond	Back of lens ground
9-B	Clear Green Glass	Diamond	Back of lens ground
9-C	Clear Glass	Diamond	
9-D	Clear Amber Glass	Diamond	Back of lens ground

Types No. 74 and No. 75

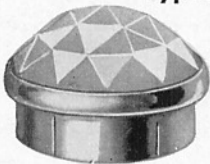

Types 74 and 75 lamp caps fit 13/16 inch holes. The nickel plated shanks are 7/32 inch long. They fit Dean pilot jacks and are also used in signal work.

Code No.	Color	Face of Lens	Description
74	White Opalescent	Diamond	
74-D	Clear Amber Glass	Diamond	Back of lens ground
75	Red Opalescent	Diamond	Back of lens ground
75-B	Clear Green Glass	Diamond	Back of lens ground

Type No. 4

Type No. 4 lamp caps fit 1-7/16 inch holes. They are similar in appearance to type No. 74 lamp caps shown above.

Code No.	Color	Face of Lens	Description
4	Red Opalescent	Diamond	Back of lens ground
7	White Opalescent	Diamond	Back of lens ground

Type No. 155



Type No. 155 lamp caps fit 7/16 inch holes. The length of the shank is 11/32 inch. The caps fit A. E. lamp jacks No. G-30. The shank is finished in lacquered, oxidized copper.

Code No.	Color	Face of Lens	Description
155	White Opalescent	Convex	
155-A	Clear Red Glass	Convex	Back of lens ground
155-B	Clear Green Glass	Convex	Back of lens ground
155-C	Clear Amber Glass	Diamond	Back of lens ground

Lamp Jacks

All Kellogg lamp jacks are designed so that the standard switchboard lamp is securely held in proper position, furnishing maximum light to the caps.

The lamp jack strip has a heavy brass frame finished in a dull nickel. The springs are German silver, and the insulators are phenol fibre insuring lasting electrical qualities. The face of the strip is of heavy brass, finished with a durable coating of black enamel that will not chip under ordinary usage.

Each lamp is partitioned by a brass strip preventing leakage of light to the adjoining caps.

Individual Lamp Jacks

No. 39

No. 39 is an individual lamp jack the frame of which is made of steel and given a rust-proof coating. To give the standard switchboard lamp the proper brilliancy this jack must be mounted on a 7/8 inch panel. The overall length of the jack including springs is 1-11/16 inches. Mountings are on 5/8 inch centers.

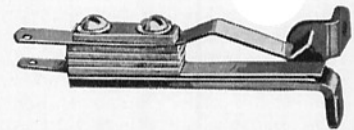

No. 49

No. 49 individual lamp jack has a steel frame with a rust-proof coating. This jack is for mounting on a 9/64 inch panel and on 9/16 inch centers. No. 154 type lamp cap is used. Single hole mounting.



Five Per Strip

No. 37

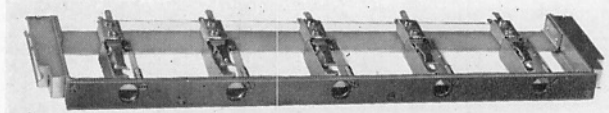

No. 37 is a strip of 5 lamp jacks with standard mounting pin centers of 11-5/32 inches. The jacks are spaced 2 inches apart and the face of the strip is 10 1/4 inches long and 1/2 inch wide. Each jack is drilled for the Kellogg standard No. 154 type lamp cap.

Ten Jacks Per Strip

No. 34

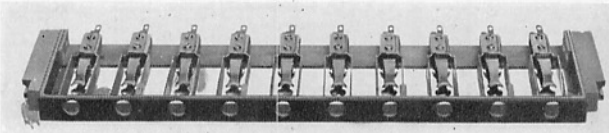

No. 34 is the standard strip of 10 lamp jacks, having mounting pin centers of 11-5/32 inches. The face of the strip is 10 1/4 inches long and 1/2 inch wide. The jacks are spaced 1 inch apart. Each jack is drilled for Kellogg standard No. 154 type lamp cap.

No. 31

No. 31 is a strip of 10 lamp jacks having mounting pin centers of 8-9/32 inches. The jacks are spaced 3/4 inch apart and the face of the strip is 7-21/32 inches long by 1/2 inch wide. Each jack is drilled to take the Kellogg standard No. 154 type lamp cap.

LAMP JACKS and METERS

Lamp Jacks — Cont.

Twenty Jacks Per Strip

No. 25

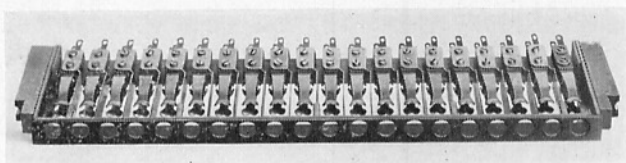

No. 25 is the standard strip of 20 lamp jacks having mounting pin centers of 11-5/32 inches. The face of the strip is 10 1/4 inches long by 1/2 inch wide. The jacks are spaced 1/2 inch apart. Each jack is drilled to mount the Kellogg standard No. 154 type lamp cap.

No. 41

Code No. 41 is a strip of 20 lamp jacks having mounting pin centers of 8-9/32 inches. The jacks are spaced 3/8 inch apart and the face of the strip is 7-21/32 inches long and 7/16 inch wide. Each jack is drilled to mount Kellogg No. 79 type lamp cap.

Lines up with No. 239 spring jack.

Jack Mounting Pins, Lugs and Clips

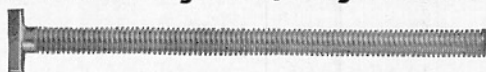

Piece No. 28489 Mounting Pin

Pc. No. 29027
Levin Lug



Pc. No. 1872
Levin Lug

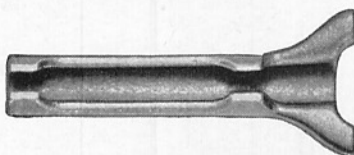

Pc. No. 29026
Levin Lug

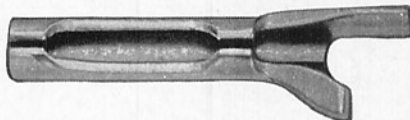

Pc. No. 2169
Clip



Pc. No. 2800
Clip



Piece No.	Description
28489	Standard pin for split style lug mounting, 3 in. long.
29735	Pin for use with jack blanks, 27/32 in. long.
29027	Levin lug, 2 3/8 in. long.
29026	Levin lug, 1 7/8 in. long.
1872	Levin lug, 2 1/4 in. long.
2169	Retaining clip for holding two strips of jacks.
2800	Retaining clip for holding one strip of jacks.
989	Nut for mounting fastening jacks.
3988	Washer used with above piece parts.

Meters

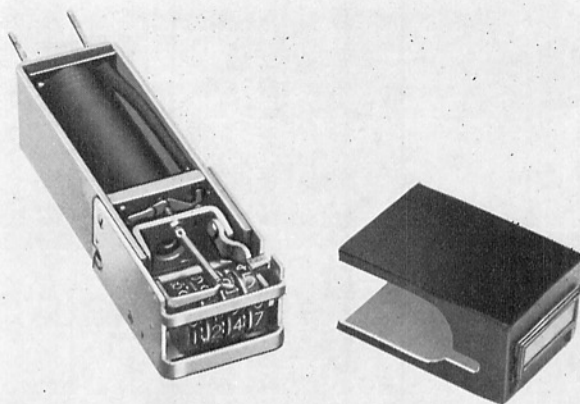

Kellogg message meters are electrically operated and are very accurate. The relays used are Kellogg standard with a special armature which insures ample movement to properly operate the counter. The cover is of pressed steel, heavily black enameled.

These meters are standard equipment in Kellogg Masterbuilt Switchboards and have many special uses and applications where consecutive numbering records are required. They can be mounted individually or in strips. Overall dimensions are 1 1/2 inches wide, 1 3/8 inches high and 5-11/16 inches deep.

Other frequencies than those shown below are available.

Code No.	Resistance	Operates on Volts
5-A	300 ohms	24
5-B	500 ohms	48

Mountings for Kellogg Message Meters

Individual Mountings

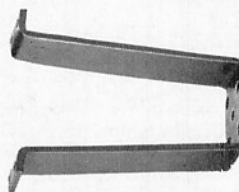

No. 380

No. 380 mounts on wood and is furnished with 2 mounting screws. It is made of steel finished with black enamel.

Strip Mountings

No. 446



No. 446 mounts five meters. Mounting centers of the strip are 9 1/2 inches. Overall size is 10 in. x 1-3/16 in. x 3/16 in. It is made of steel, finished with black enamel.

No. 1023

No. 1023 mounts 15 meters. It will mount on relay gates. It is made of steel, black enameled. Overall length is 26 inches and the width is 2 inches. Mounting centers of the strip are 25 1/4 inches.

Switchboard Section

SWITCHBOARD APPARATUS

NUMBER PLATES and DESIGNATION STRIPS

Spring Jack Type Number Plates

No. 2



No. 2 number plates are used for designation purposes on No. 201 spring jacks. They are made of brass, heavily black enameled. The inscription, as specified, is filled with white lead, making a clean cut designation. Dimensions are $\frac{3}{8}$ by $\frac{1}{4}$ inch.

No. 3

No. 3 number plate is identical to No. 2 except for size. It fits No. 195 spring jack. Dimensions are $\frac{5}{16}$ inch by $\frac{7}{16}$ inch.

Plug Shelf Type Number Plates

No. 4



No. 4 number plates are used for numbering the different panels of each position or section of a switchboard. They are made of polished white ivory, $\frac{1}{8}$ -inch thick, and $\frac{3}{4}$ of an inch in diameter. The inscription is engraved as specified and filled with black paint.

No. 5

No. 5 number plates are used for numbering each cord circuit. They are $\frac{3}{8}$ inch in diameter, $\frac{1}{8}$ -inch thick, and are made of white polished ivory. The numerals are engraved as specified and filled with black paint.

Drop and Jack Type Number Plates

No. 10



No. 10 number plates are standard for numbering drops and jacks. They are carried in stock, numbered from 0 to 999 and are made of German Silver having a black lacquered finish. The numerals are brightly polished. Dimensions of number plate: $\frac{5}{8}$ inch by $\frac{5}{16}$ inch.

Stile Strip Type Number Plates

No. 46

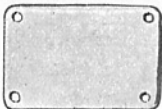

No. 46 number plates are used for numbering the different positions of a switchboard. They are made of white polished ivory having the numerals, as specified, engraved and filled with black paint. Overall dimensions: $1\frac{3}{4}$ inches by $1\frac{1}{4}$ inches.

No. 57

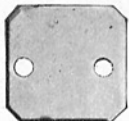

No. 57 number plate is the standard stile strip number plate. Made of white polished ivory, the numerals are engraved as specified and filled with black paint. Overall dimensions, $\frac{11}{16}$ inch square. Use two No. 5959 screws for stiles $\frac{1}{8}$ inch thick. For stile strips of No. 14 B. & S. gauge, use two No. 26226 screws. Screws are furnished only when specified.

No. 116

No. 116 number plate is the same as No. 57 except that it is made of red opaque polished celluloid. The same mounting screws are used as listed with code No. 57.

Designation Strips

Kellogg designation strip holders are made from drawn brass, heavily black enameled. White paper inserts are used under a clear celluloid cover. These strips of paper are easily removed for lettering or replacement.

Type No. 7 strips shown below are $\frac{17}{32}$ inch wide and can be furnished in the lengths listed. No. 5964 wood mounting screws are furnished only when specified.

Type No. 7



Code No.	Overall Length	No. of Mtg. Screws Required
22	1-7/16 in.	2
17	5 1/2 in.	2
28	8-3/16 in.	3
16	9 1/2 in.	3
15	10 in.	3
10	10 1/4 in.	3
33	11 1/2 in.	5
19	13-7/16 in.	4
26	15 1/2 in.	5
30	17 in.	4
7	19 1/2 in.	5
9	20-9/16 in.	5
8	21-11/16 in.	5

Type No. 13



No. 13 type designation strips are similar to No. 7 in general construction. No. 13 strips, however, are mounted on black enameled blank jack panels to harmonize in finish with the face plate of the switchboard.

Code No.	Mtg. Centers	Width of Panel	Dimensions of Designation Strip
31	8 1/4 in.	1/2 in.	7/16x7-9/16 in.
23	8 1/4 in.	3/8 in.	23/64x7-9/16 in.
13	11-5/32 in.	1/2 in.	7/16x 10 in.
20	11-5/32 in.	7/16 in.	7/16x 10 in.

Indicator Pins — Party Line

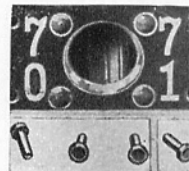

Indicator pins are used on multiple jacks and indicate the equipped stations on a party line. They fit the drillings in the face of the spring jack as shown in the illustration.

Concave Head Type

This type of indicator pin is made from iron wire properly treated to prevent rust. The head is concave and filled with colored lacquer.

Code No.	Color	Code No.	Color
5	Red	8	Blue
6	White	15	Yellow
7	Green		

Celluloid Head Type

This indicator pin is also made of iron wire properly treated to prevent rust but head is made of solid celluloid.

Code No.	Color	Code No.	Color
10	Red	13	Blue
11	White	14	Yellow
12	Green		

NO. 1000 TYPE CAM KEYS

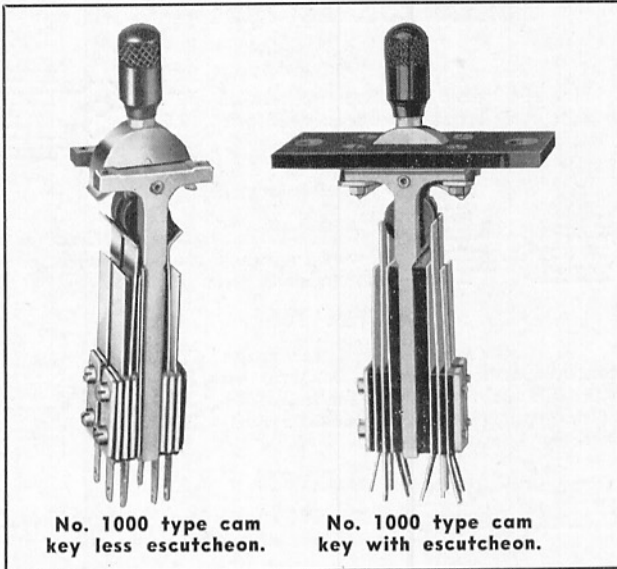

No. 1000 type cam key less escutcheon.

No. 1000 type cam key with escutcheon.

Kellogg cam keys are built on a perfect center line or T frame, making it possible to assemble any number of spring combinations of either the locking, restoring or both locking and restoring types, which are always interchangeable with each other.

All bushings, insulations and rollers are made from phenol fibre, which will not carbonize or break down under high voltage and which will stand up under the most rigid and persistent usage.

The T frame, typical of Kellogg cam keys, and the assembling screws are made of brass. The springs are made of German silver with precious metal contacts, eliminating the possibility of corrosion and giving perfect talking and ringing connections in every operation.

The scientific basis on which Kellogg keys are constructed, with proper distribution of wear, insures long life and positive contacts.

Keys mounted on escutcheons should be ordered so that the first key mentioned on the order will be the key nearest the operator when installed, and so that all locking keys are farthest from the operator. Net weight each is 3½ ounces. Escutcheons are not furnished unless specified.

Single Locking Type

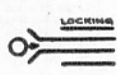

No. 1001
No. 1001 cam keys have two sets of make contacts.

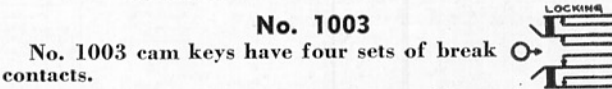

No. 1003
No. 1003 cam keys have four sets of break contacts.

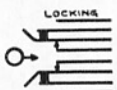

No. 1004
No. 1004 cam keys have two sets of break contacts and two sets of make contacts.

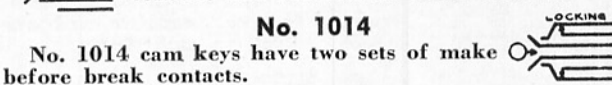

No. 1014
No. 1014 cam keys have two sets of make contacts before break contacts.

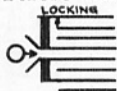

No. 1017
No. 1017 cam keys have one set of break contacts and three sets of make contacts.

Single Locking Type — Cont.

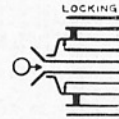

No. 1025

No. 1025 cam keys have two sets of make before break contacts and two sets of make contacts.

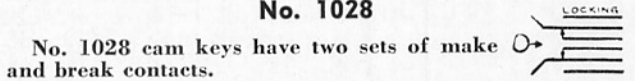

No. 1028

No. 1028 cam keys have two sets of make and break contacts.

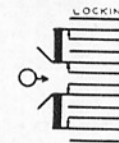

No. 1034

No. 1034 cam keys have four sets of make and break contacts.

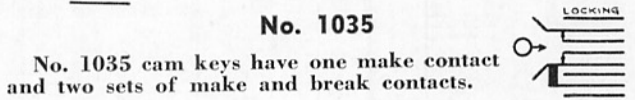

No. 1035

No. 1035 cam keys have one make contact and two sets of make and break contacts.

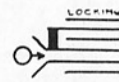

No. 1042

No. 1042 cam keys have three sets of make contacts.

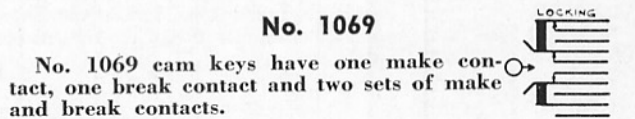

No. 1069

No. 1069 cam keys have one make contact, one break contact and two sets of make and break contacts.



No. 1070

No. 1070 cam keys have two break contacts and four make contacts.

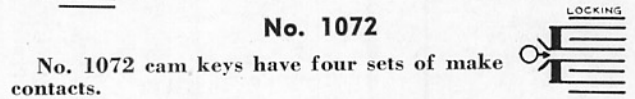

No. 1072

No. 1072 cam keys have four sets of make contacts.



No. 1102

No. 1102 cam keys have three sets of make and break contacts.

Single Restoring Type — Non-Locking

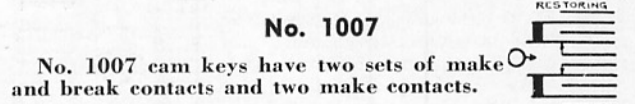

No. 1007

No. 1007 cam keys have two sets of make and break contacts and two make contacts.



No. 1008

No. 1008 cam keys have two sets of make and break contacts and two break contacts.

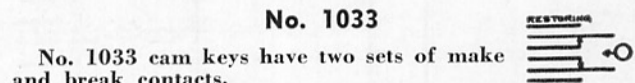

No. 1033

No. 1033 cam keys have two sets of make and break contacts.

Piece parts for 1000 type cam keys are shown on pages 33, 34 and 35.

Switchboard Section

SWITCHBOARD APPARATUS

NO. 1000 TYPE CAM KEYS

Double Locking Type

No. 1002

No. 1002 cam key has two sets of make contacts on each side.

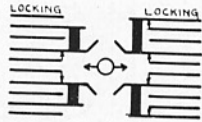

No. 1010

No. 1010 cam key has two sets of make and break contacts and two make contacts on one side and two sets of make and break contacts and two break contacts on the other side.



No. 1011

No. 1011 cam key has four sets of make contacts on each side.

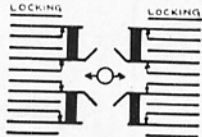

No. 1013

No. 1013 cam key has four sets of make and break contacts on each side.

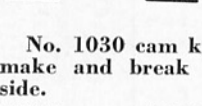

No. 1030

No. 1030 cam key has two sets of make and break contacts on each side.

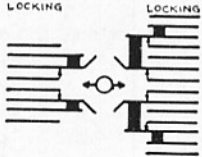

No. 1082

No. 1082 cam key has two make contacts and two break contacts on one side and two sets of make and break contacts, two make contacts and two break contacts on the other side.

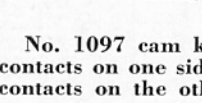

No. 1097

No. 1097 cam key has two make contacts on one side and three make contacts on the other side.

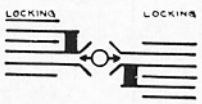

No. 1098

No. 1098 cam key has three make contacts on each side.

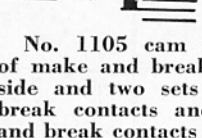

No. 1105

No. 1105 cam key has two sets of make and break contacts on one side and two sets of make before break contacts and two sets make and break contacts on the other side.

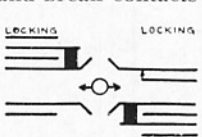

No. 1113

No. 1113 cam key has three sets of make contacts on one side and two sets of make contacts and one break contact on the other side.

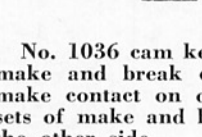

No. 1036

No. 1036 cam key has two sets of make and break contacts and one make contact on one side and two sets of make and break contacts on the other side.

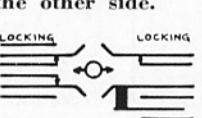

No. 1037

No. 1037 cam key has two sets of make and break contacts on one side and two make contacts and one break contact on the other side.

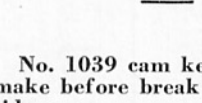

No. 1039

No. 1039 cam key has two sets of make before break contacts on each side.

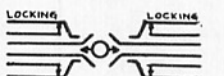
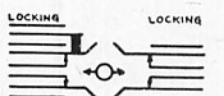
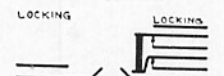
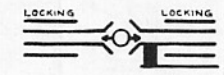
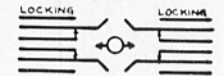
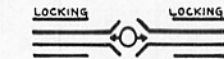

Double Locking Type — Cont.

No. 1049

No. 1049 cam key has two sets of make and break contacts and one make contact on each side.



No. 1051

No. 1051 cam key has three sets of make contacts and one break contact on each side.



No. 1052

No. 1052 cam key has three make contacts and two break contacts on one side and two sets of make before break contacts and two make contacts on the other side.

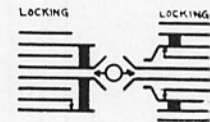

No. 1059

No. 1059 cam key has two sets of break contacts on each side.

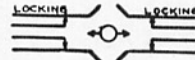

No. 1065

No. 1065 cam key has four sets of make and break contacts on one side and two sets of make before break contacts on the other side.

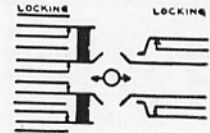

No. 1067

No. 1067 cam key has two sets of make and break contacts, one make contact and one break contact, on each side.

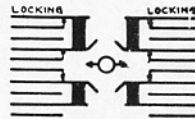

No. 1074

No. 1074 cam key has two sets of make before break contacts and one make contact on each side.

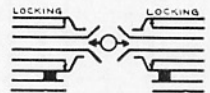

No. 1114

No. 1114 cam key has two sets of break contacts and one make contact on each side.

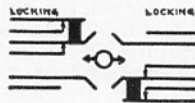

No. 1128

No. 1128 cam key has two sets of make contacts and two sets of make before break contacts on each side.

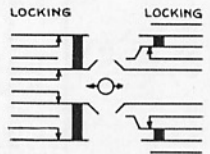

Double Restoring Type

No. 1050

No. 1050 cam key has two sets of make and break contacts and one make contact on each side.

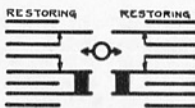

No. 1031

No. 1031 cam key has two sets of make and break contacts on each side.

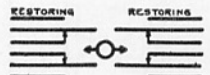

NO. 1000 TYPE CAM KEYS

Locking and Restoring Type

No. 1016

No. 1016 cam key has two sets of make and break contacts on the restoring side and four sets of make and break contacts on the locking side.

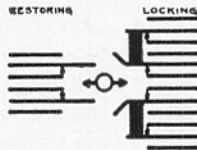

No. 1021

No. 1021 cam key has one set of make contacts and two makes and one break contact on the restoring side and three make contacts on the locking side.

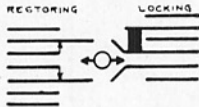

No. 1023

No. 1023 cam key has two sets of make and break contacts on the restoring side, and four sets of make contacts on the locking side.

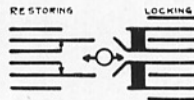

No. 1024

No. 1024 cam key has two sets of make and break contacts and one make contact on each side.

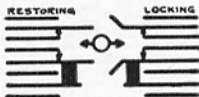

No. 1026

No. 1026 cam key has two sets of make and break contacts on the restoring side and two sets of make before break contacts and two make contacts on the locking side.

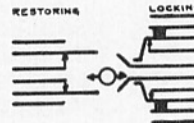

No. 1027

No. 1027 cam key has two sets of make and break contacts on the restoring side and two sets of make before break contacts on the locking side.

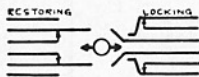

No. 1029

No. 1029 cam key has two sets of make and break contacts on each side.

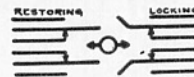

No. 1032

No. 1032 cam key has two sets of make and break contacts on the restoring side and two sets of make and break contacts and one make contact on the locking side.

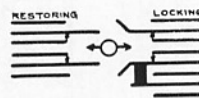

No. 1041

No. 1041 cam key has two sets of make and break contacts on the restoring side and two sets of make contacts on the locking side.

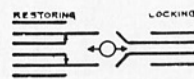

No. 1058

No. 1058 cam key has two sets of make before break contacts on the restoring side and two sets of make before break contacts and one make contact on the locking side.

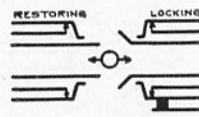

No. 1043

No. 1043 cam key has two sets of make and break contacts on the restoring side and three sets of make contacts on the locking side.

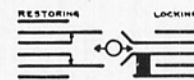

Meteor Metal Contacts

The keys listed below are of the same construction as the No. 1000 type key except they are equipped with heavy meteor metal contacts.

Single Locking Type

No. 1005

No. 1005 key has two sets of make contacts.



No. 1127

No. 1127 key has two break contacts.

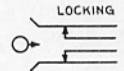

Double Locking Type

No. 1019

No. 1019 key has two sets of make and break contacts on each side.

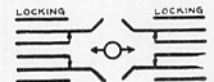

No. 1020

No. 1020 key has two sets of make contacts on each side.

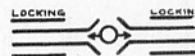

Escutcheons for Cam Keys

The following standard escutcheons for the 1000 type of cam keys are made of brass, heavily black enameled, giving a rich finished appearance to the key. For those desiring blank key escutcheons, Kellogg carries a large variety in stock and will gladly quote on your requirements. Mounting screws are not furnished unless specified on the order.

Single Type Escutcheon

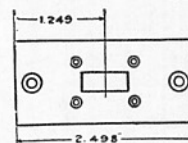

Code No.	Length Overall	Width Overall
1053	2 1/2 inches	3/4 inch
1054	2 1/2 inches	13/16 inch
1055	2 1/2 inches	7/8 inch
1021	2 1/2 inches	1 inch

Code No.	Length Overall	Width Overall
1022	1 5/8 inches	15/16 inch

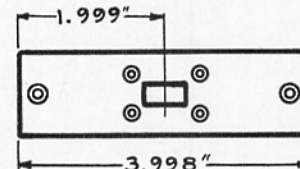
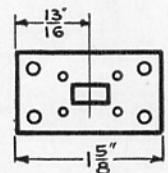

Code No.	Length Overall	Width Overall
1069	4 inches	3/4 inch

Key Blanks

Key blanks are made of cold rolled steel, handsomely finished in black enamel. Mounting screws are furnished if specified. No. 142 key blank is 5 1/2 inches long and 1 1/8 inches wide.



Code No.	Description
142	Blank for No. 1000 type key.
28870	Machine screws for No. 142 dummy plug.

Piece parts for 1000 type cam keys are shown on pages 33, 34 and 35.

Switchboard Section

SWITCHBOARD APPARATUS

ESCUTCHEONS for CAM KEYS

Double Type Escutcheons

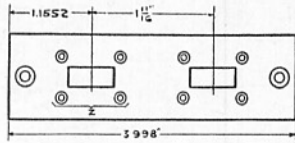

Code No.	Length Overall	Width Overall	Description
1070	4 inches	3/4 inch	
1015	4 inches	13/16 inch	
1016	4 inches	13/16 inch	Less Hole Z
1013	4 inches	1 inch	
1011	4 inches	1 inch	Less Hole Z
1085	4 inches	1 1/8 inches	
1012	4 inches	1-3/16 inches	
1010	4 inches	1-3/16 inches	Less Hole Z
1026	4 inches	1-9/32 inches	

Special Escutcheon For W. E. Switchboards

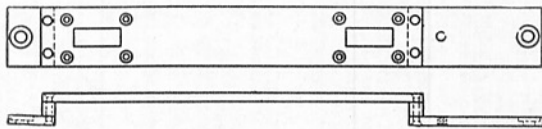

Code No.	Length Overall	Width Overall
1049	7-21/64 inches	27/32 inch

Triple Type Escutcheons

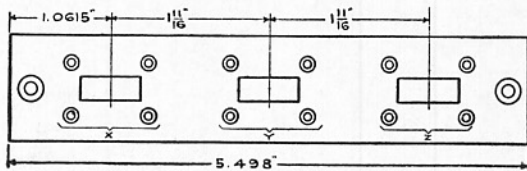

Code No.	Length Overall	Width Overall	Description
1040	5 1/2 inches	3/4 inch	Less Hole Y
1076	5 1/2 inches	3/4 inch	Less Hole Z
1078	5 1/2 inches	3/4 inch	Less Holes Y and Z
1014	5 1/2 inches	13/16 inch	
1057	5 1/2 inches	13/16 inch	Less Hole Y
1074	5 1/2 inches	1 inch	
1041	5 1/2 inches	1 inch	Less Hole Y
1077	5 1/2 inches	1 inch	Less Hole Z
1075	5 1/2 inches	1 inch	Less Holes Y and Z
1080	5 1/2 inches	1-1/16 inches	Less Holes Y and Z

Triple Type Escutcheons — Cont.

Code No.	Length Overall	Width Overall	Description
1000	5 1/2 inches	1 1/8 inches	
1002	5 1/2 inches	1 1/8 inches	Less Hole Y
1004	5 1/2 inches	1 1/8 inches	Less Hole Z
1001	5 1/2 inches	1 1/8 inches	Less Holes Y and Z
1003	5 1/2 inches	1 1/8 inches	Less Holes X and Z
1071	5 1/2 inches	1-3/16 inches	
1043	5 1/2 inches	1-3/16 inches	Less Hole Z
1030	5 1/2 inches	1-9/32 inches	
1031	5 1/2 inches	1-9/32 inches	Less Hole Y
1065	5 1/2 inches	1-9/32 inches	Less Hole Z

Quadruple Type Escutcheons

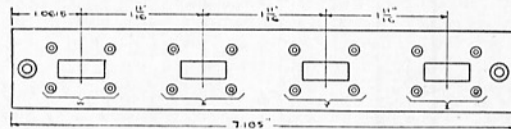

Code No.	Length Overall	Width Overall	Description
1051	7-3/16 inches	13/16 inch	
1036	7-3/16 inches	1 inch	Less Hole W
1032	7-3/16 inches	1 inch	Less Holes X and W
1037	7-3/16 inches	1 inch	Less Holes X, Y and W
1007	7-3/16 inches	1 1/8 inches	

Vertical Type Escutcheons

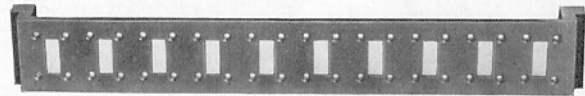

Five Per Strip

Code No.	Width Inches	Length Inches	Key Centers Inches	Mounting Centers Inches
405	1 3/4	5 7/8	1-9/64	6 3/4
454	1 1/4	10 1/4	2	11-5/32

Six Per Strip

435*	1 3/4	11-3/32	1	10-21/32
------	-------	---------	---	----------

*Screw mounted from the front.

Ten Per Strip

400	1 1/2	10 1/4	1	11-5/32
453	1 1/4	10 1/4	1	11-5/32

FOUR PARTY KEYS

Kellogg four party ringing keys are of the same superior construction as the No. 1000 type cam keys. They are known for their long life, freedom from trouble and ease of operation. The key buttons are of tough, hard composition mounted on heavy brass rods, retained in position with tempered steel spiral springs. The frame is of great strength and cannot warp or bind the keys. The springs are of German silver with non-corrosive contact metal. Bakelite insulation is used throughout. The sliding bar is of steel actuated by bronze pins. Buttons are furnished in standard colors, black, green, red and blue.

With the Kellogg type of construction, it is impossible to ring more than one party on a line at one time.

Locking Type Arranged for Release by a Cam Key

The push button remains in operating position until restored by the cam key or by operation of one of the other buttons.

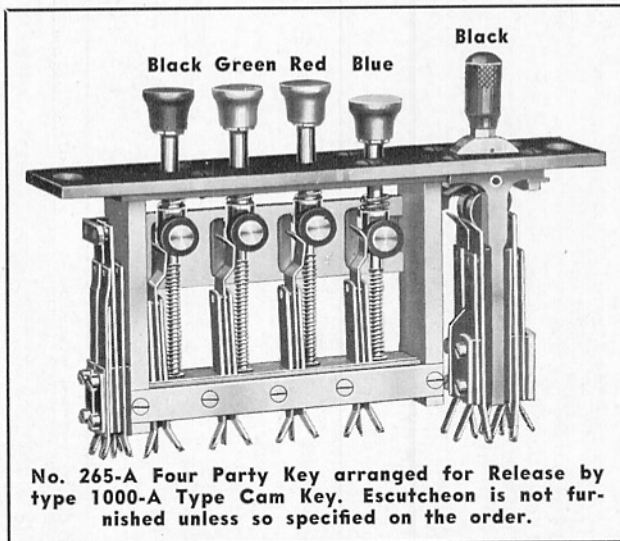

The following keys are arranged to be released by any of the new style cam keys listed at the right. In ordering, please specify the code number of the four party key, the cam key and the escutcheon on which they are to be mounted.

No. 265-A

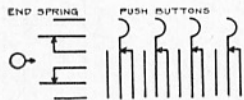

No. 265-A has one set of make and break contacts. The end spring has two make and break contacts. There are two extra dead terminals on the end springs.

No. 267-A

No. 267-A has one set of make and break contacts.

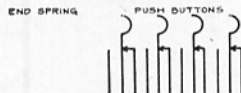

No. 355-A

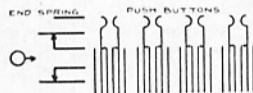

No. 355-A has two sets of make and break contacts. There are two extra dead terminals on the end springs.

1000 Type Cam Keys for Four Party Cam Release Keys Double Restoring Type

No. 1060-A



No. 1060-A has two sets of make and break contacts, two sets of make contacts.

No. 1061-A

No. 1061-A has two sets of make and break contacts.



Locking and Restoring Type

No. 1044-A

No. 1044-A has two make and break contacts on the restoring side and two make contacts on the locking side.

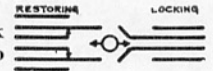

No. 1045-A

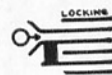

No. 1045-A has three make contacts on the locking side.

No. 1046-A

No. 1046-A has two make and break contacts on the restoring side and three make contacts on the locking side.

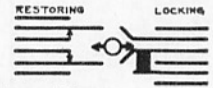

No. 1047-A

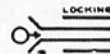

No. 1047-A has two make contacts on the locking side.

No. 1053-A

No. 1053-A has two sets of make contacts and two sets of break contacts on the locking side.

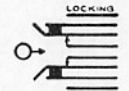

No. 1062-A

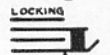

No. 1062-A has two make and break contacts and two make contacts on the locking side.

No. 1063-A

No. 1063-A has one set of make before break contacts and three make contacts on the locking side.



No. 1118



No. 1118 has two sets of make and break contacts, one break contact on the restoring side and two sets of make before break contacts and one make contact on the locking side.

No. 1125-A

No. 1125-A has two sets of break and two sets of make contacts on the locking side and two sets of make and break contacts on the restoring side.

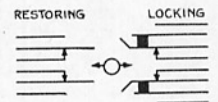

Single Restoring Type

No. 1000-A

No. 1000-A is a dummy release key.

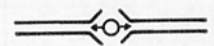

No. 1015-A



No. 1015-A has two make and break contacts on the restoring side.

Piece parts for Four Party Keys are shown on page 36.

Switchboard Section

SWITCHBOARD APPARATUS

TWO and FOUR PARTY KEYS

Four Party Keys Locking Type Less Cam Key Release

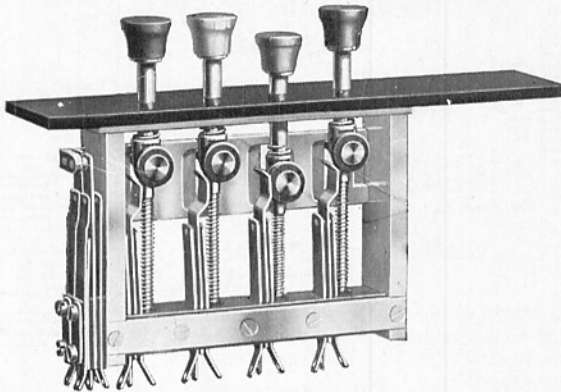

Escutcheons for Four Party Keys — Cont. 8 7/8 inches Long

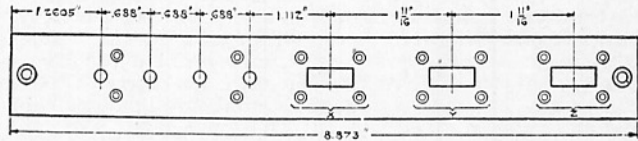

Code No.	Length Overall	Width Overall	Description
1017	8 7/8 inches	1 1/8 inches	

Two Party Keys Locking Type, Not Released By Cam

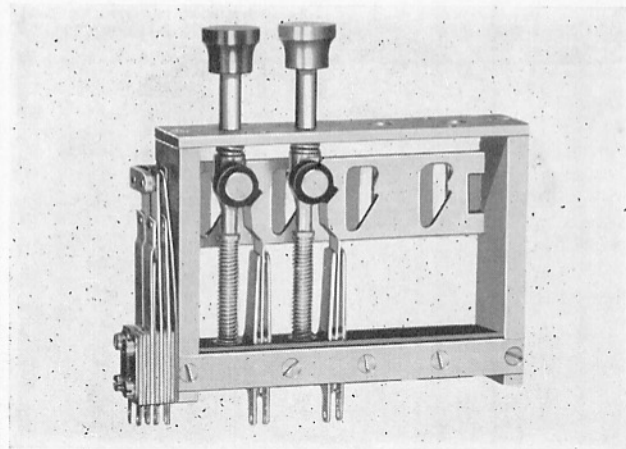

The push button remains in operating position until restored by operation of one of the other buttons. The escutcheon is not furnished unless specified on the order.

No. 266

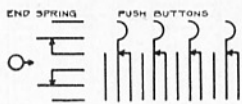

No. 266 has one set of make and break contacts. The end spring has 2 make and break contacts. There are two extra dead terminals on the end springs.

No. 310

No. 310 has one set of make and break contacts. There are two blank springs.

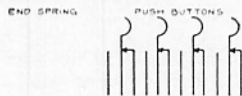

Escutcheons for Four Party Keys

With and Without Cam Release Key
5 1/2 inches long

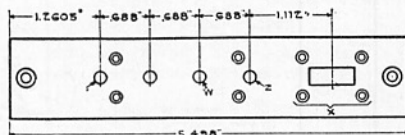

Code No.	Length Overall	Width Overall	Description
1027	5 1/2 inches	3/4 inch	
1028	5 1/2 inches	3/4 inch	Less Hole X
1039	5 1/2 inches	1 inch	
1038	5 1/2 inches	1-1/16 inches	
1005	5 1/2 inches	1 1/8 inches	
1006	5 1/2 inches	1 1/8 inches	Less Hole X

7-3/16 inches Long

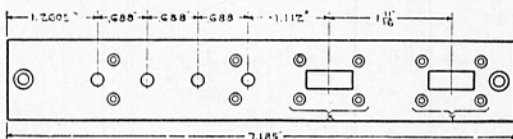

Code No.	Length Overall	Width Overall	Description
1033	7-3/16 inches	1 inch	
1008	7-3/16 inches	1 1/8 inches	
1009	7-3/16 inches	1 1/8 inches	Less Hole Y

No. 317

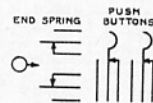

No. 317 has one set of make and break contacts. The end spring has two make and break contacts. These keys mount on a 1000 type escutcheon, shown on page 31. The two keys occupy the two center holes of the standard four party frame.

No. 328

No. 328 has one set of make and break contacts. The end spring has two make and break contacts. These keys mount on 1000 type escutcheon, in the end holes of the standard four party key frame. Buttons are black and red.

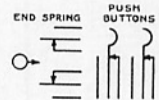

Locking Type, Released By Cam

No. 358-A

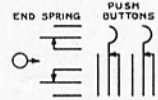

No. 358-A has one set of make and break contacts. The end spring has two make and break contacts. It is the same as No. 328 shown above except it is released by a No. 1000-A type cam key, shown on page 29. Uses 1000 type escutcheon.

Piece parts for four party keys are shown on page 36

ORDER WIRE KEYS

Two Party Keys — Locking Type, Released by Cam

No. 359-A

No. 359-A has 2 make and break contacts. The end spring has 2 make and break contacts. The two keys mount on a 1000 type escutcheon in the two end holes of a standard four party key frame.

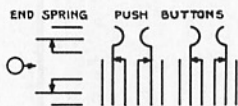

Escutcheons for Two Party Keys

5 1/2 inches Long

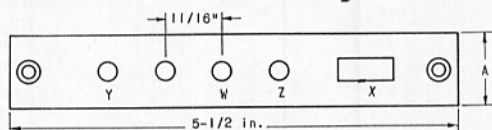

Available with or without hole for mounting 1000 type cam key.

Code No.	Width A	Description
1047	5/8 inch	Less holes X, W and Z
1050	7/8 inch	Less holes Z and W
1064	1 inch	Less holes X, W and Z
1086	1-1/16 inch	Less holes X, W and Z
1046	1 1/8 inch	Less holes Y and Z

7-3/16 inches Long

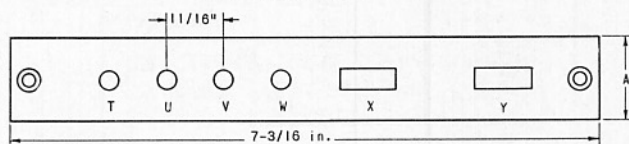

Available with or without hole for mounting 1000 type cam key.

Code No.	Width A	Description
1061	1 inch	Less holes X, Y, W and V
1062	1 inch	Less holes W and V
1062-R	1 inch	Rubber faced, with end brackets and mounting lugs.
1111	1 1/8 inch	Less holes W and V Less holes V and W

Order Wire Keys — Push Button Type

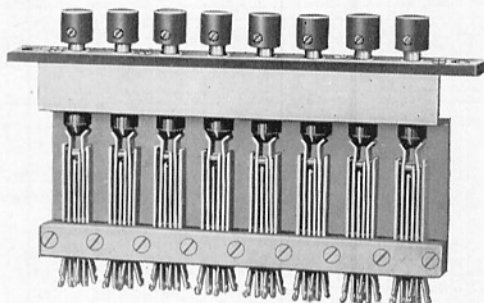

These keys are of the same sturdy construction as the four party keys. The frames are of heavy brass, nickel plated. The buttons are made of hard black rubber.

Order Wire Keys — Push Button Type

Restoring Type — Eight Keys Per Strip

Code No.	Spring Combination	Length Inches	Width Inches	Jack Mtg. Centers Inches
301		5 1/2	1/2	1/2
318		5 1/2	1/2	1/2

No. 301 has 3 sets of make contacts and No. 318 has two sets of make contacts.

Escutcheons for No. 301 and 318 Keys

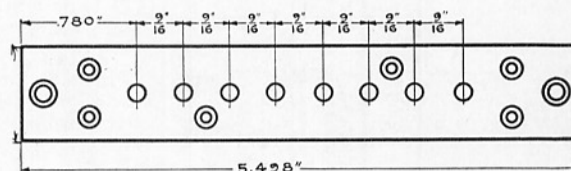

No. 1023 escutcheons is made of hard drawn brass, handsomely finished in black enamel. It is 5 1/2 inches long and 1/2 inch wide.

Locking Type, Ten and Twenty Keys Per Strip

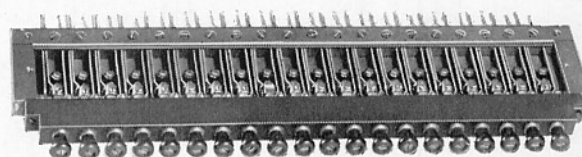

Similar to spring jacks in construction except equipped with plugs. Mounting centers are 11-5/32 inches. The face of the strip is 10 1/4 inches long and 7/16 inch wide.

No. 314 mounts 10 jacks per strip on 1 inch centers and No. 313 mounts 20 jacks per strip on 1/2 inch centers.

Code No.	Spring Combination	No. per Strip	Description
314		10	Uses No. 273 spring jack.
313		20	Uses No. 261 spring jack.

Switchboard Section

SWITCHBOARD APPARATUS

ORDER WIRE KEYS and MOUNTINGS

Order Wire Keys — Push Button Type

Restoring Type, 10 Keys Per Strip

Code No.	Dimensions of Face Strip	Mtg. Pin Centers	Contacts
312	10¼ x ½ in.	11-5/32 in.	2 make
330	10¼ x ½ in.	11-5/32 in.	2 break
327	7-21/32 x ½ in.	8-9/32 in.	2 make

Restoring Type, 20 Keys Per Strip

366	10¼ x ½ in.	11-5/32 in.	2 make
-----	-------------	-------------	--------

Individual Order Wire Keys

In keeping with Kellogg standards, the frames of these individual order wire keys are of heavy brass, nickel plated. Buttons are made of hard black rubber and the springs of German silver with non-corrosive contacts. Length is 2¾ inches, not including the button.

Locking Type



Mounts on wood on 5/8 inch centers.

Code No.	Spring Combination	Thickness of Mounting	Contacts
255		¾ inch	2 Make and Break
167		7/8 inch	2 Make and Break
269		7/8 inch	2 Make
300*		7/8 inch	2 Make

*Meteor Metal Contacts.

Restoring Type

Mounts on wood.

Code No.	Spring Combination	Thickness of Mounting	Contacts
254		¾ inch	2 Make and Break
302		7/8 inch	2 Make and Break

Individual Order Wire Keys

Restoring Type

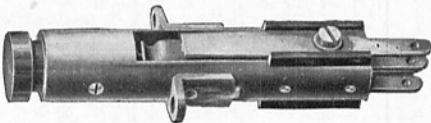

These restoring type individual order wire keys mount on wood on 5/8 inch centers.

Individual Order Wire Keys, Restoring Type—(Continued)

Code No.	Spring Combination	Thickness of Mounting	Contacts
5		7/8 inch	2 Make
66		7/8 inch	1 Make and 2 Break
296		7/8 inch	3 Make
24		7/8 inch	2 Make and Break
367		7/8 inch	2 Break

No. 172

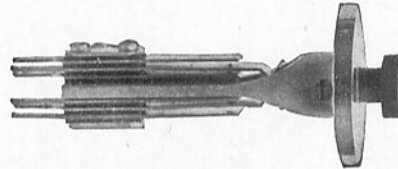

No. 172, restoring type, individual order wire key mounts on wood or metal on 1-5/16 inch centers.

Code No.	Spring Combination	Description
172		Metal escutcheon, 1¼ inch diameter.

Order Wire Key Mounting For Mounting Two Keys

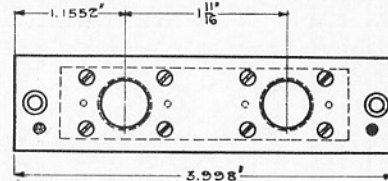

Order wire key mountings are made of brass, heavily black enameled. Holes are ½ inch in diameter.

Code No.	Width	Description
1024	1 inch	Mounts two keys

For Mounting Three Keys

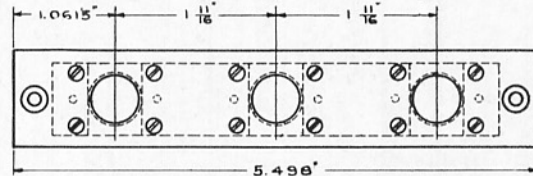

Code No.	Width	Description
1042	13/16 inch	Mounts three keys
1083	1 inch	Mounts three keys

Key Escutcheon Clamps

The standard clamp is made of steel, copper plated.

Piece No.	Description
27783	Clamp for the No. 1000 type escutcheon.
15044	¾ inch machine bolt, black enamel head.

Switchboard Section
SWITCHBOARD APPARATUS

NO. 1000 TYPE CAM KEYS--PIECE PARTS

No. 1002 Key

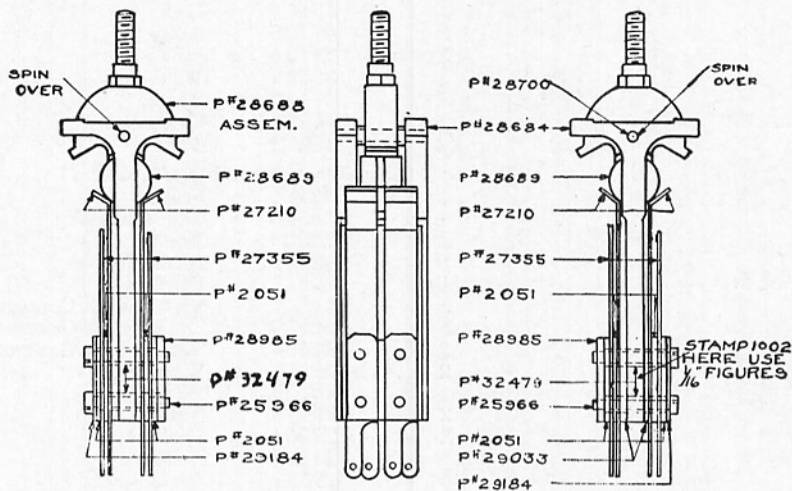

No. of Pieces	Piece Number	Description
1	15171	Handle
4	49724	Screw
1	32690	Washer
1	47557	Washer
Key Parts Assembly No. 29270		
1	28684	Frame
1	28688	Cam Assembly
2	28689	Roller
1	28700	Pin
3	2051	Insulation
2	29033	Insulation
4	27210	Spring with Contact
4	27355	Spring with Contact
2	28985	Nut
4	32479	Bushing
2	29184	Washer
4	25966	Special Screw

No. 1029 Key

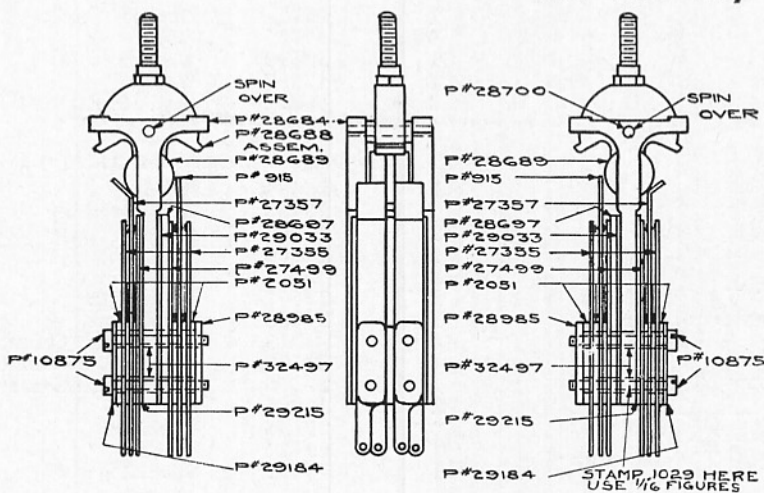

No. of Pieces	Piece Number	Description
1	15171	Handle
2	49726	Screw
2	49724	Screw
1	32690	Washer
1	47557	Washer
1	46221	Cam Stop
2	28872	Nut

Key Parts Assembly No. 29267

Key Parts Assembly No. 29267 is the same as No. 29270 shown above except for the following: No. 29267 has two No. 915, four No. 27355, two No. 27357, and four No. 27499 Springs with Contacts instead of those shown for Assembly No. 29270; No. 29267 has twelve No. 2051, one No. 29215, one No. 28697 and two No. 29033 Insulators in addition to those shown for No. 29270; and No. 29267 uses four No. 10875 Screws instead of No. 25966 and four No. 32497 Bushings instead of No. 32497.

No. 1030 Key

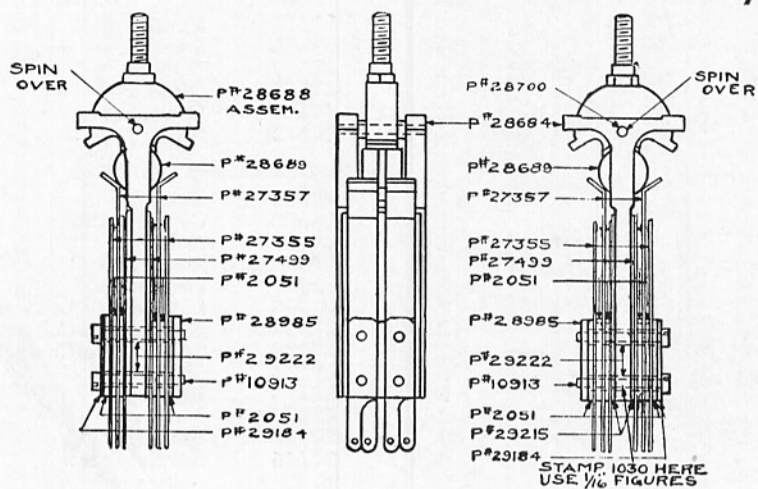

No. of Pieces	Piece Number	Description
1	15171	Handle
4	49724	Screw
1	32690	Washer
1	47557	Washer

Key Parts Assembly No. 29272

1	28684	Frame
1	28688	Cam Assembly
2	28689	Roller
1	28700	Pin
12	2051	Insulation
2	29215	Insulation
4	27357	Spring with Contact
4	27355	Spring with Contact
4	27499	Spring with Contact
2	28985	Nut
4	29222	Bushing
2	29184	Washer
4	10913	Special Screw

Switchboard Section

SWITCHBOARD APPARATUS

NO. 1000 TYPE CAM KEYS — PIECE PARTS

No. 1028 Key

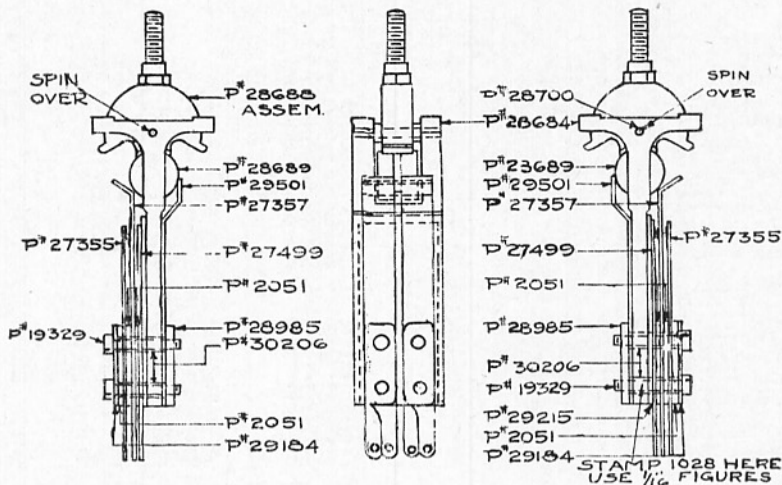

No. of Pieces	Piece Number	Description
1	15171	Handle
2	49726	Screw
2	49724	Screw
1	32690	Washer
1	47557	Washer
1	46221	Cam Stop
2	28872	Nut
Key Parts Assembly No. 29259		
1	28684	Frame
1	28688	Cam Assembly
2	28689	Roller
6	2051	Insulation
1	29215	Insulation
2	27357	Spring with Contact
2	27355	Spring with Contact
2	27499	Spring with Contact
2	29184	Washer
1	28700	Pin
2	28985	Nut
2	29501	Springs
4	30206	Bushing
4	19329	Special Screw

No. 1031 Key

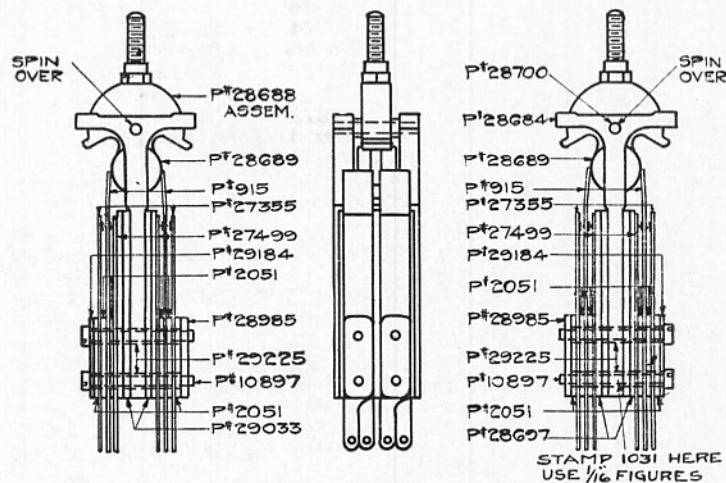

No. of Pieces	Piece Number	Description
1	15171	Handle
4	49726	Screw
1	32690	Washer
1	47557	Washer
2	46221	Cam Stop
4	28872	Nut
Key Parts Assembly No. 29276		
1	28684	Frame
1	28688	Cam Assembly
2	28689	Roller
1	28700	Pin
12	2051	Insulation
2	28697	Insulation
2	29033	Insulation
4	915	Spring with Contact
4	27499	Spring with Contact
4	27355	Spring with Contact
2	28985	Nut
4	29225	Bushing
2	29184	Washer
4	10897	Special Screw

No. 1033 Key

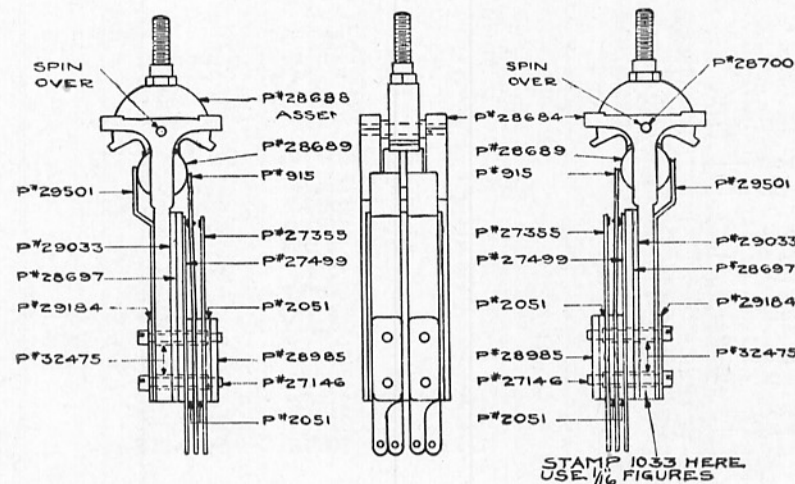

No. of Pieces	Piece Number	Description
1	15171	Handle
4	49726	Screw
1	32690	Washer
1	41557	Washer
2	46221	Cam Stop
4	28872	Nut
Key Parts Assembly No. 29266		
1	28684	Frame
1	28688	Cam Assembly
2	28689	Roller
1	29033	Insulation
8	2051	Insulation
2	915	Spring with Contact
2	27355	Spring with Contact
2	27499	Spring with Contact
2	29184	Washer
2	32475	Bushing
2	28985	Nut
2	29501	Springs
4	27146	Special Screw

Switchboard Section

SWITCHBOARD APPARATUS

NO. 1000 TYPE CAM KEYS—PIECE PARTS

No. 1041 Key

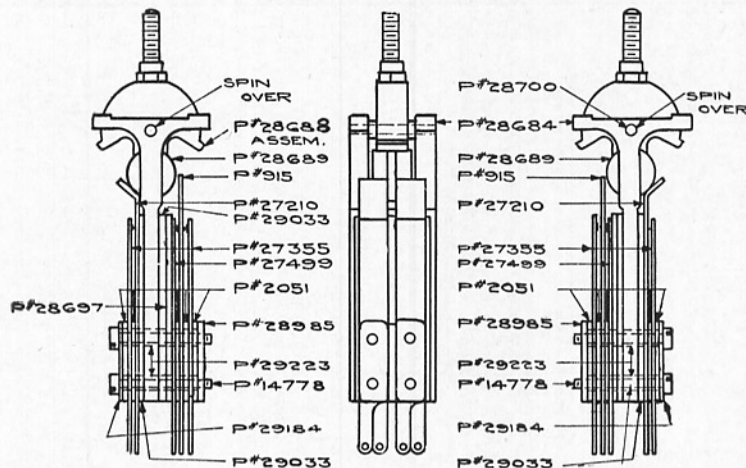

Key No. 1041 is the same as Key No. 1042 shown below except No. 1041 uses Key Parts Assembly No. 28752 instead of No. 29262.

Key Parts Assembly No. 28752

No. of Pieces	Piece Number	Description
1	28684	Frame
1	28688	Cam Assembly
2	28689	Roller
1	28700	Pin
2	29033	Insulation
1	28697	Insulation
10	2051	Insulation
2	915	Spring with Contact
2	27210	Spring with Contact
4	27355	Spring with Contact
2	27499	Spring with Contact
2	29184	Washer
4	29223	Bushing
2	28985	Nut
4	14778	Special Screw

No. 1042 Key

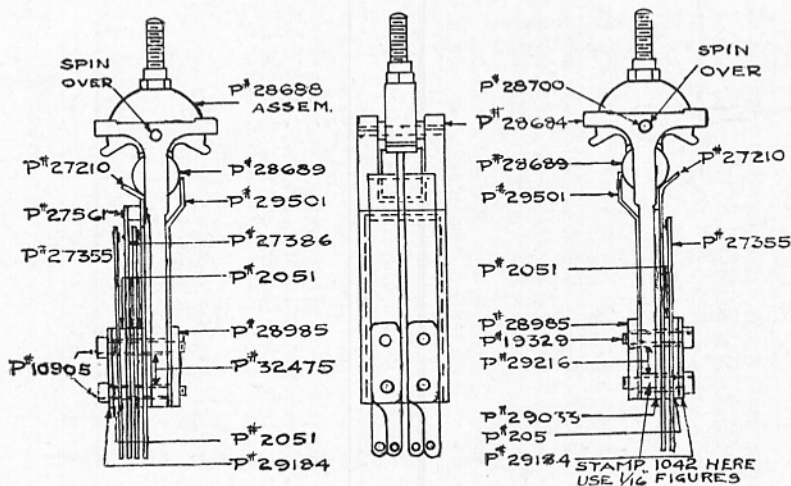

No. of Pieces	Piece Number	Description
1	15171	Handle
2	49726	Screw
2	49724	Screw
1	32690	Washer
1	47557	Washer
1	46221	Cam Stop
2	28872	Nut

Key Parts Assembly No. 29262

No. of Pieces	Piece Number	Description
1	28684	Frame
1	28688	Cam Assembly
2	28689	Roller
6	2051	Insulation
1	29033	Insulation
2	27210	Spring with Contact
1	27386	Spring with Contact
3	27355	Spring with Contact
2	29184	Washer
2	32475	Bushing
1	28700	Pin
1	27561	Separator
2	28985	Nut
2	29501	Spring
2	29126	Bushing
2	10905	Special Screw
2	19329	Special Screw

No. 1043 Key

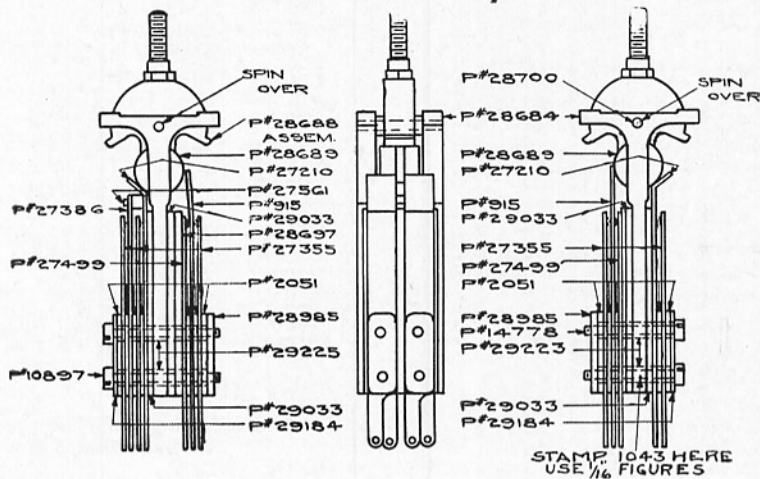

Key No. 1043 is the same as Key No. 1042 shown above except No. 1043 uses Key Parts Assembly No. 29269 instead of No. 29262.

Key Parts Assembly No. 29269

No. of Pieces	Piece Number	Description
1	28684	Frame
1	28688	Cam Assembly
2	28689	Roller
1	28700	Pin
2	29033	Insulation
1	28697	Insulation
12	2051	Insulation
2	27210	Spring with Contact
2	915	Spring with Contact
2	27355	Spring with Contact
5	27386	Spring with Contact
1	27386	Spring with Contact
2	27499	Spring with Contact
1	27561	Separator
2	29184	Washer
2	29223	Bushing
2	29223	Bushing
2	28985	Nut
2	14478	Special Screw
2	10897	Special Screw

Switchboard Section

SWITCHBOARD APPARATUS

FOUR PARTY KEYS--PIECE PARTS
No. 265 Four Party Key

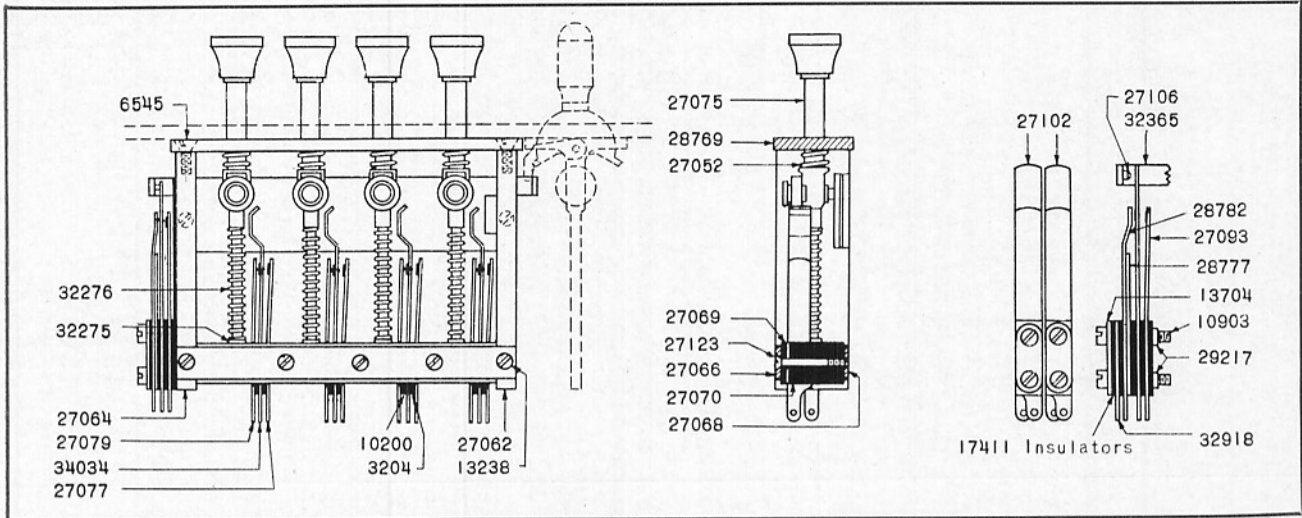

Piece Parts for Key No. 265

No. of Pieces	Piece Number	Description
2	27093	Spring with Contact
2	28782	Spring with Contact
2	27102	Spring with Contact
1	32365	Release Strip
2	28777	Stiffener
1	27056	Guide
4	29217	Bushing
2	32918	Terminals
10	17411	Insulation
2	27106	Insulation
4	29023	Special Screw
4	55624	Spring Washer
2	13704	Washer
4	10903	Special Screw
2	13238	Special Screw
1	3992	Button No. 1
1	3993	Button No. 2
1	3994	Button No. 3
1	3995	Button No. 4
2	33437	Insulation

Key Parts Assembly No. 46793

4	3204	Insulation
4	10200	Insulation
4	32275	Washer
4	27052	Spring
1	28769	Mounting Plate
1	27062	Upright
1	27064	Upright
1	27066	Front Strip
1	27068	Rear Strip
1	27069	Insulation
1	27070	Mounting Block
4	27075	Plunger Assembly
4	27077	Spring with Contact
4	27079	Spring with Contact
4	34034	Spring with Contact
4	32276	Spring
4	13238	Special Screw
2	6545	Special Screw
3	27123	Special Screw

Key No. 265-A

Key No. 265-A is the same as No. 265 except that No. 265-A uses Release Strip No. 49757, and no No. 33437 Insulators.

Key No. 267

No. of Pieces	Piece Number	Description
2	27101	Restoring Spring
2	33437	Insulation
2	17952	Insulation
1	32365	Release Strip
1	46793	Key Parts Assembly
1	27056	Guide
4	47031	Bushing
4	17411	Insulation
2	27106	Insulation
4	29023	Special Screw
4	55624	Spring Washer
2	13704	Washer
4	27142	Special Screw
2	13238	Special Screw
1	3992	Button No. 1
1	3993	Button No. 2
1	3994	Button No. 3
1	3995	Button No. 4

Key Parts Assembly No. 46793

The stock list for Key Parts Assembly No. 46793 used in No. 267 Key is the same as the Key Parts Assembly shown for Key No. 265.

Key No. 267-A

No. 267-A Key is the same as Key No. 267 except that No. 267-A Key uses Release Strip No. 49757.

Key No. 355

No. of Pieces	Piece Number	Description
1	27056	Guide
1	32365	Release Strip
2	28777	Stiffener

Key No. 355 — Cont.

No. of Pieces	Piece Number	Description
2	27102	Spring with Contact
2	27093	Spring with Contact
2	28782	Spring with Contact
2	27106	Insulation
10	17411	Insulation
1	33437	Insulation
4	29217	Bushing
2	32918	Terminal
4	55624	Spring Washer
2	13704	Washer
2	13238	Special Screw
4	10903	Special Screw
1	3992	Button No. 1
1	3993	Button No. 2
1	3994	Button No. 3
1	3995	Button No. 4
4	29023	Special Screw

Key Parts Assembly No. 46795

1	28769	Mounting Plate
1	27062	Upright
1	27064	Upright
2	34037	Strip
1	47167	Insulation
8	3204	Insulation
8	10200	Insulation
1	47166	Mounting Block
4	27075	Plunger Assembly
4	34034	Spring with Contact
4	27087	Spring with Contact
8	27077	Spring with Contact
8	27079	Spring with Contact
4	27052	Spring
4	32276	Spring
4	32275	Washer
4	13238	Special Screw
8	47169	Special Screw
2	6545	Special Screw

Key No. 355-A

Key No. 355-A is the same as No. 355 except that No. 355-A uses Release Strip No. 49757.

OPERATOR'S BREASTPLATE SETS

Operator's Breastplate Set

With The Kellogg NON-POSITIONAL Transmitter

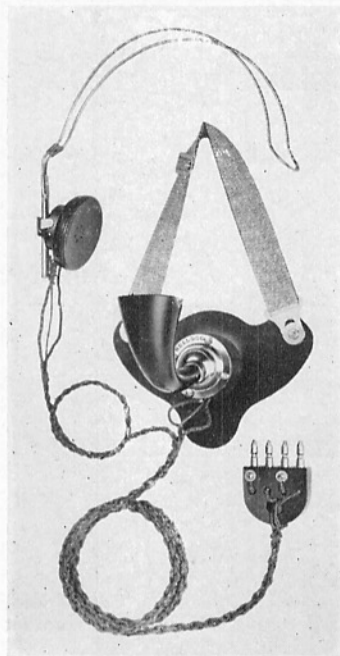

The Kellogg NON-POSITIONAL transmitter is used in the No. 177 type lightweight operator's breastplate set. This feature eliminates the possibility of "dead" talking positions and means that transmission efficiency remains at its peak regardless of the position or angle of the instrument. The patented spherical electrode construction of this NON-POSITIONAL transmitter guarantees a constant and uniform flow of current between the electrodes at all times, and the carbon granules will not pack. Because this transmitter covers a wide range of the voice frequencies, there is a decided gain in articulation and understandability of the transmitted voice.

This new breastplate transmitter is small in size, weighs only 6 $\frac{3}{8}$ ounces, and is moistureproof. When used in anti-side tone circuits there is a decided gain in the effective reception because the operator's receiver does not have to compete with the side tone and room noises.

The NON-POSITIONAL unit is sealed in a sturdy aluminum housing only 1-13/16 inches in diameter. The hard rubber mouthpiece screws into a nickel plated front with a ball and socket joint that permits adjustment to any talking position. The black enameled aluminum breastplate is 4 in. x 5 $\frac{7}{8}$ in. The adjustable band is made of a high grade, gray cotton tape with clips at both ends for easy removal or attachment. Overall length, including mouthpieces, is 6 in. and the total weight including band, is only 6 $\frac{3}{8}$ ounces.

No. 177-C NON-POSITIONAL Breastplate Transmitter. Mouthpiece and Band for magneto and common battery switchboards.

No. 177-L — Same as No. 177-C but for local battery operation only, for railway dispatchers, etc., and where extra transmission is more important than battery consumption.

Major Parts Used in No. 177-C and 177-L Operator's Breastplate Set

No. of Pieces	Piece No.	Description
1	5176	Joint Spring
1	58012	Band Assembly
1	58004	Mouthpiece
1	59847	Breastplate Assem.

Featherweight Operator's Receiver

This receiver is illustrated in the picture in the left hand column.

There's real comfort for operators in this small watch-case type receiver. It weighs only 1 $\frac{3}{4}$ ounces and with headband, only 3 ounces. The diameter of the case is only half that of older types but the Bakelite cap is large and so shaped that the receiver is more comfortable to the wearer and better reception is assured. Cobalt steel magnets make possible the lighter weight and smaller size and this assures long life and unusual sensitivity. The diaphragm is not affected by temperature variations . . . the wire headband is adjustable, and cord terminals are concealed but easily accessible without removing the cap. The resistance of this receiver is 56 ohms, and its impedance is 300 ohms at 1000 cycles. It can be used equally well on magneto or common battery switchboards.

This new featherweight receiver and headband makes an ideal companion unit for the new type 177 NON-POSITIONAL Breastplate Transmitter. They were developed to improve efficiency and to assure greater comfort for your operators.

No. 85-A — Featherweight Receiver for magneto or common battery switchboards.

No. 14 — Headband for No. 85-A Receiver.

Major Parts Used in No. 85-A Receiver

No. of Pieces	Piece Part No.	Description
1	59915	Shell Assembly
1	59891	Cap
1	59892	Coil Assembly
1	59893	Coil Assembly
1	59907	Magnet
1	59918	Diaphragm

Mouthpieces for Breastplate Type Operator's Sets

Piece No. 29776 — Used with No. 76 type breastplate operator's set.

Piece No. 39354 — Used with No. 1076 type breastplate operator's set.

Piece No. 58004 — Used with No. 177 type breastplate operator's set.

Operator's Breastplate Set No. 1076-C & 1076-L

Piece Parts

No. of Pieces	Part No.	Description
1	15761	Bridge Assembly
2	9175	Cushion
4	2975	Nut
1	2972	Mouthpiece Support
1	5176	Joint Spring
1	59241	Breastplate Assem.
1	12834	Throat
1	8542	Union Assembly
1	17099	Insulator
1	39354	Mouthpiece
1	58012	Band Assembly
1	39353	Cover
1	29637	Diaphragm Assem. (No. 1076-C Only)
1	9448	Diaphragm Assem. (No. 1076-L Only)

Switchboard Section

SWITCHBOARD APPARATUS

OPERATOR'S SETS and TRANSMITTER ARMS

Suspended Type Operator's Sets

With One Piece Bakelite Transmitter Front and Mouthpiece, and the Kellogg Non-Positional Transmitter

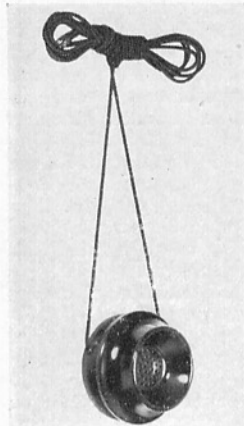

No. 156

Molded of rich, black Bakelite this one-piece unit is practically indestructible. It takes the famous NON-POSITIONAL transmitter and makes this one unit standard for all sets. The locating lugs on the transmitter case slip into corresponding guide slots in the Bakelite housing. The electrical connections are made by two heavy blades engaging the bronze contact clips. These blades are formed with one end providing a slotted terminal to which the transmitter cord may be soldered. Each blade is positioned between two Bakelite

shoulders and anchored by a single screw.

These suspended type transmitters are standard for all types of switchboards using this style of operator's sets. Furnished with two 72-inch transmitter cords.

No. 156-C is used for common battery or for local battery operation. No. 156-L is used for local battery operation only, such as railways, oil field lines, etc., where extra transmission is more important than battery consumption.

Major Parts

Code No. of Operator's Set	Piece Assembly	Parts Front
156-C	57340	61926
156-L	58799	61926

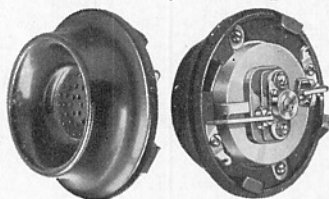

Operator's Receivers

No. 65-A

The No. 65-A type operator's receiver, combining efficiency and permanent, satisfying service, is an equipment that will be appreciated by the operator and manager alike. The total weight of receiver and band is 3.9 ounces. The total width is 2-3/16 inches and the depth or thickness 7/8 inches. Terminals are entirely enclosed within the shell and solid horse-shoe permanent magnet, and electro-magnets of high grade wire are wound on cores of special magnet iron. The head



Operator's Receiver No. 65-A—(Continued)

band is arranged to permit the receiver to be adjusted in any position that is most comfortable to the wearer. Standard for all switchboards.

Code No.	Resistance	Shipping Weight
65-A	100-Ohms	8 oz.

No. 12 Head Band

Wire head band for single receiver. For No. 65-A Transmitter only. Weight 2 oz.

Switchboard Transmitter Arms

No. 48

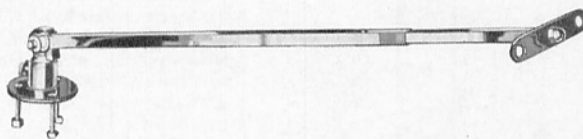

The No. 48 transmitter arm is of the suspended adjustable type, made of heavy brass with a durable nickel finish. It can be used on all types of small switchboards.

This type of arm eliminates the use of a cord weight. It is equipped with both horizontal and vertical swivel joints, making it easy to place the transmitter in any position convenient for the operator. This arm is especially valuable for use with PBX or magneto switchboards where the operator or attendant has other work to do and uses an adjoining desk or counter.

No. 48 transmitter arms are arranged for type 156 transmitters. The standard length is 15 1/2 inches and net weight is 1 3/8 lbs. The base is made of malleable iron and the base and front are black enameled.

No. 28

This transmitter arm is used on desk type or small, floor type boards. It is made of brass tubing, heavily nickel plated. The cords are concealed in this tube. The arm is equipped with a swivel joint so that it can be swung to the right or left.

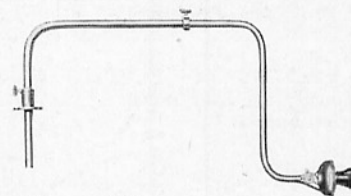

Lengths from 16 1/4 inches to 22 3/4 inches are available. No. 28 transmitter arm is arranged for the type 121 transmitter.

KELLOGG MICROMETER ADJUSTMENT PILOT RELAYS

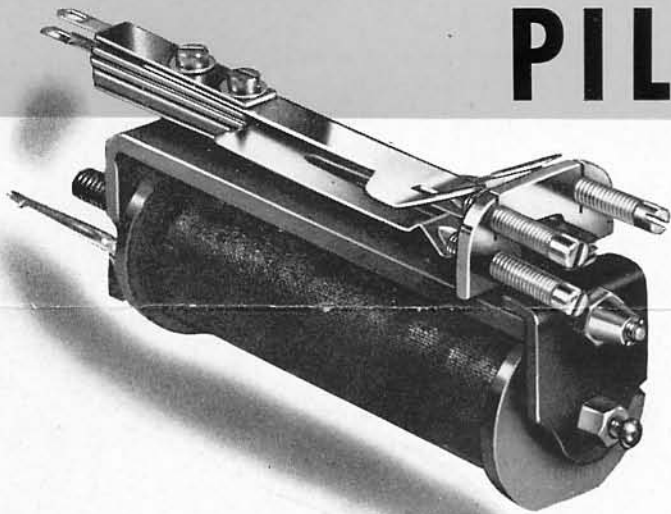

Positive, Precise Adjustment — No Special Tools Needed!

THE smooth operation of pilot relays is essential to the successful operation of any switchboard. Keeping these pilot relays in adjustment for this smooth operation has always been a major maintenance problem. In a constant effort to develop new products and new methods that simplify maintenance of telephone and central office equipment Kellogg has again made an important step by eliminating the spring bending method of adjusting pilot relays.

The new Kellogg Pilot Relays are adjusted positively and precisely by a new method. The secret of this new type relay is the three adjusting screws that regulate the position and tension of the springs. The outer ends of these screws are slotted for a screw driver and are readily accessible. Each screw presses against a spring and turning the screw in or out increases tension against the spring or raises the spring up or down thus adjusting the relay for a perfect operation.

THESE MICROMETER ADJUSTMENT RELAYS ARE DESIGNED TO OPERATE UNDER ALL TYPES OF SERVICE CONDITIONS . . . AND WITH ALL TYPES OF CARBON AND TUNGSTEN SWITCHBOARD LAMPS.

They are now standard equipment on all new Kellogg switchboards and are available for replacement of the older type relays in switchboards now in service.

They are designed especially for use in: *Line Pilot Circuits . . . Night Alarm and Fuse Alarm Circuits . . . Answering and Calling Supervisory Pilot on the Cord Circuits . . . Trunk Pilot Circuits . . . Toll Pilot Circuits . . . Rural Line Pilot Circuits . . . Cord Supervisory Circuits . . . Trunk Supervisory Circuits.*

This relay is designed with the added feature of an adjustable residual pin.

Simple Design and Sturdy Construction

Kellogg relays are of simple design and sturdy construction. The angle type armature and simple adjustment insure reliable operation under the severe operating con-

ditions which relays must meet in telephone service. Because of the importance of this positive, unfailing relay operation, Kellogg relays are built to the most exacting specifications.

The iron used in cores and frame is not only selected with extreme care, but each lot is tested and analyzed by every means known to the modern laboratory before it is passed to the manufacturing departments.

Cores and frames are carefully annealed in sealed pots to prevent the possibility of residual magnetism. The long resilient springs are constructed from the finest grade of German silver. Contact points are of special precious metal.

Coils contain liberal winding space allowing the maximum number of turns and insuring a wide margin of operation.

Easy to Install

The new type Micrometer Adjustment Pilot Relay is easy to install. It is only necessary to unsolder wiring on the terminals of the present pilot relay, remove the relay from the mounting strip, place the new pilot relay on the mounting strip and solder the necessary wires to the proper terminals on the new relay. It will fit in the same place and on the same mounting strip as is occupied by the present No. 2043-SEQ pilot relay.

The cover used with the new relay is so designed that two relays will mount under one cover. When a relay is ordered singly a double mounting plate is furnished and one space is left vacant. The relay coil furnished is the regular Kellogg 2000 type. Kellogg relays are adjusted for operation before they leave the factory but sometimes minor adjustments are necessary when they are placed in service.

Ordering Information

When replacing your present No. 2043-SEQ Pilot Relay with the new Micrometer Adjustment type Pilot Relay No. 2102-SHG, the order should read:

No. 2102-SHG Relay, unmounted, including No. 63151 Cover. The price of the relay and cover is \$4.75 each, F. O. B. Chicago, Illinois.

Micrometer Adjustments

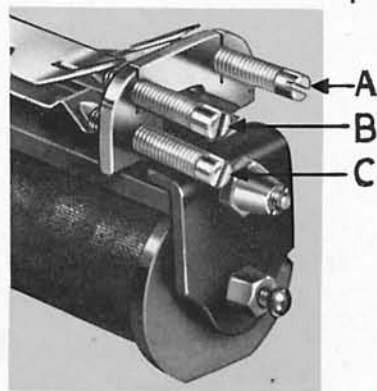

Turning adjusting screw "A" in a clockwise direction raises the bottom spring.

Turning adjusting screw "B" in a clockwise direction raises the top spring of the relay.

Turning adjusting screw "C" in a clockwise direction increases the tension on the middle or rear spring of the relay.

KELLOGG SWITCHBOARD AND SUPPLY COMPANY
Factory and General Offices: 6650 S. CICERO AVE., CHICAGO, ILL., U. S. A.

RELAYS

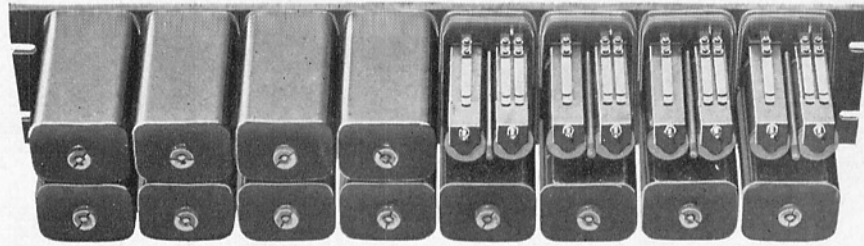

A strip of 16 pairs of No. 2000 type relays on a No. 1006 mounting strip, showing relays with and without shell covers.

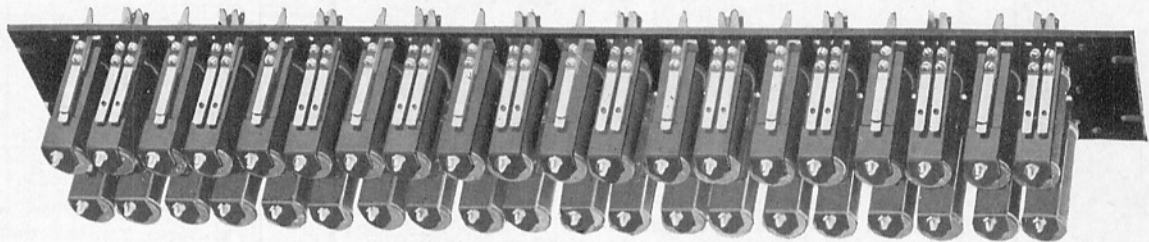

A strip of 20 pairs of No. 2000 type relays on a No. 1008 mounting strip. A single can cover is shown below.

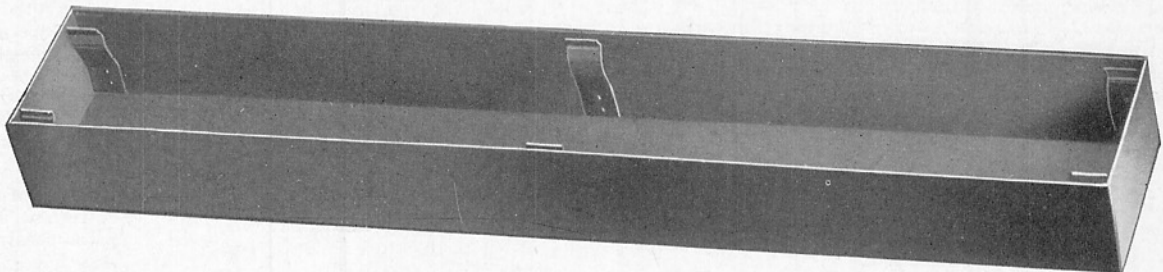

Kellogg relays are of simple design and sturdy construction. The angle type armature and simple adjustment insure reliable operation under the severe conditions which relays must meet in telephone service. Because of the importance of positive, unfailing relay operation, Kellogg relays are built to the most exacting specifications.

The iron used in cores and frame is not only selected with extreme care, but each lot is tested and restored by every means known to the modern laboratory before it is passed to the manufacturing departments.

Cores and frames are carefully annealed in sealed pots to prevent the possibility of residual magnetism. The long resilient springs are constructed from the finest grade of German silver. Contact points are of special precious metal.

Coils contain liberal winding space allowing the maximum number of turns and insuring a wide margin of operation.

Heavy mounting plate and cover, with adequate knurled and slotted nut secured to permanently, riveted cover, insures absolute stability to both relay and cover, obviating any possible interference with relay action.

Relay Shell Covers

All the shell covers for relays have the same dimen-

sions, as shown in the table below.

The shell cover for the No. 546 polarized relay is made of brass. All other relay shell covers are made of steel with an aluminum or black enamel finish.

Description	Dimension
Length Overall	3 $\frac{3}{4}$ inches
Height Overall	1-13/16 inches
Width Overall	2 $\frac{3}{8}$ inches

2000 Type Relays

The 2000 type relays are Kellogg standard and are used on practically all new work. They can be furnished in a large variety of spring combinations and coil resistances.

These relays can be mounted in pairs and each pair provided with a drawn cover. When 2000 type relays are ordered singly the double mounting plate is furnished and one space is left vacant. A variety of mounting strips may be had, including angle mountings for mounting single pairs.

Only a partial listing of Kellogg relays and relay coils is given. If a suitable relay cannot be found, please submit complete specifications, and Kellogg engineers will promptly give recommendations. Send wiring diagram of circuit to facilitate selecting proper type relay.

Switchboard Section

SWITCHBOARD APPARATUS

2000 TYPE RELAYS

2000 Type Relay Less Cover and Mounting

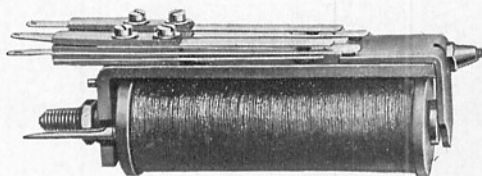

Description	Dimension
Length Overall	4 1/4 in.
Length to Back of Mounting	3-1/16 in.
Height Overall	1 5/8 in.
Length of Relay Coil	2-11/16 in.

2000 Type Relays

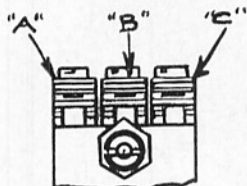

This end view of a No. 2000 type relay shows the position of the spring combinations and the slotted nut that holds the armature in the correct position. The letters in the diagram correspond to the letters in the column headings below.

The following code numbers cover the relay spring combinations only. To specify a complete relay the code number of the relay should be given, followed by the letters designating the coil wanted. Mountings are specified separately.

Make Before Break Spring Combinations

The letters under the column head "Spring Combinations" refer to positions in the diagram above.

Code No.	Spring Combination			Description
	A	B	C	
2006				One set make before break contacts.
2007				Two sets make before break contacts.
2009				Four sets make before break contacts.

Mixed Spring Combinations

2001				One set make and break contacts.
2002				Two sets make and break contacts.
2003				Three sets make and break contacts.
2004				Four sets make and break contacts.
2005				Two sets of break contacts and two sets make and break contacts.

Mixed Spring Combinations — Cont.

Code No.	Spring Combination			Description
	A	B	C	
2019				Two sets of make and break contacts and one set make before break contacts.
2021				Two sets of make and break contacts and two sets make before break contacts.
2023				Five sets of make contacts.
2026				One set of break contacts, two sets of make contacts, and two sets of make and break contacts.
2027				One set of make contacts, and four sets of make and break contacts.
2028				Two sets of make contacts, two sets of break contacts and one set of make before break contacts.
2029				One set of make contacts. For pilot relays.
2030				One set break contacts. For supervisory relays.
2031				Two sets make contacts and three sets make and break contacts.
2034				One set of break contacts and one set make and break contacts. Interrupter relay. Special tension spring.
2035				One set of break contacts and two sets of make contacts.
2036				One set of make contacts and one set make before break contacts.
2037				Two sets of make contacts.
2039				Three sets of make and break contacts with screw armature adjustment.

2000 TYPE RELAYS

Mixed Spring Combinations — Cont.

Code No.	Spring Combination			Description
	A	B	C	
2046				Four sets of make and break contacts and one set of make before break contacts.
2048				Two sets of break contacts.
2059				Three sets of break contacts.
2077				Four sets of make contacts.
2078				One set of make contacts and one set break contacts.
2079				One set of make contacts, one set of break contacts and two sets of make and break contacts.
2081				Two sets of make contacts and one set of make and break contacts.
2089				One set of make and break contacts and one set of make before break contacts.
2091				Two sets of make contacts and two sets of make and break contacts.
2093				Two sets of make contacts.

Make and Break Springs with Light Armatures

Standard 2000 type relay coils are used with these relays.

Code No.	Spring Combination	Description
2044		One set of make and break contacts.
2049		One set of break contacts.
2056		Two sets of make contacts.

Alternating Current Relays

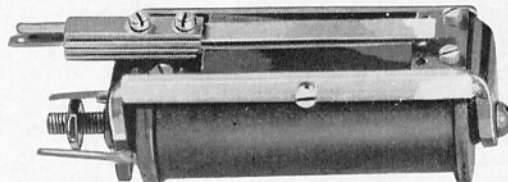

Description	Dimension
Length Overall	4 inches
Height Overall	1 3/4 inches

These alternating current relays use only the coils listed below.

Code No. of Relay	Spring Combination	Description
2017		One set of make contacts.
2018		One set of break contacts.
2052		One set of make and one set of break contacts.
2057		One make contact. Extra adjusting spring.
2085		Two sets of make contacts. Tension adjusting spring.

Relay Coils for Alternating Current Type Relays

Single Wound, 3/8 inch Core

Code No.	Resistance
S-BZ	500 ohms
S-BX	1000 ohms
S-BY	1600 ohms

A. C. Type Relays, Laminated Core

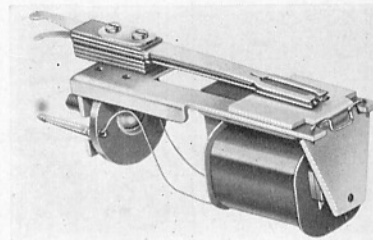

Through new design and new materials, quieter, more sensitive operation is achieved in these alternating current relays. They mount on the regular 1000 type mounting and use a coil similar to No. S-HZ.

These relays are 4 in. long, 1 in. wide, and the length to the back of mounting is 3 in.

Code No.	Spring Combination		
	A	B	C
2103			
2104			
2105			

Relay Coils for 2103, 2104 and 2105 A. C. Relays

Single Wound

Code No.	Resistance
S-HZ	75 ohms

Switchboard Section

SWITCHBOARD APPARATUS

RELAYS

Trip and Restoring Relays

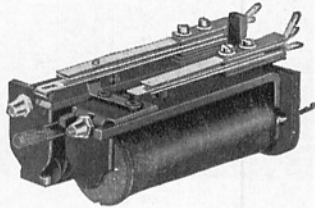

Description	Dimension
Length Overall	4 1/4 in.
Height Overall	1 5/8 in.
Length to Back of Mounting.....	3 1/8 in.

Restoring Relays

On Right Side Facing Armature

Restoring relays on right side facing armature, for use with trip relays. Restoring relays use standard 2000 type relay coils.

Code No.	Spring Combination			Description
	A	B	C	
2060				Four sets of make and break contacts.
2064				Two sets of make and break contacts.
2067				One set of make and break contacts.
2068				Three sets of make and break contacts.

Trip Relays

On Left Side Facing Armature

Trip relays use only coils listed below. For use with restoring type relay. The contacts shown in position A

Trip Relays — Cont.

make contact only momentarily, those in Position C make permanently. For use with restoring relays.

Code No.	Spring Combination			Description
	A	B	C	
2061				One set of break contacts and one set of make contacts.
2062				One set of make contacts.

Coils for Trip Relays

Single wound coils with 3/8 inch core for use with trip relay.

Code No.	Resistance
S-GN	100 ohm
S-FS	500 ohm
S-FU	1000 ohm

Harmonic Relays

Kellogg harmonic relays consist of standard harmonic ringer movements fitted with auxiliary contacts for the operation of lamp signals or other relays. The auxiliary contact has double action making contact on both sides of the armature thus doubling the contact interval.

When a subscriber is moved from one line to another his former telephone is replaced by a harmonic relay of the same frequency pending the next directory reprint. The contacts of this relay are connected to a lamp in front of the information operator who answers any calls for the old number and gives the calling party the moved subscriber's new number.

Relay Code No.	Resistance, Ohms			
	No. 1	No. 2	No. 3	No. 4
20575-A	33-1/3	50	66-2/3	16-2/3
20576-A	30	42	54	66
20577-A	25
20570-A	20	60

Mounting Strips for 2000 Type Relays

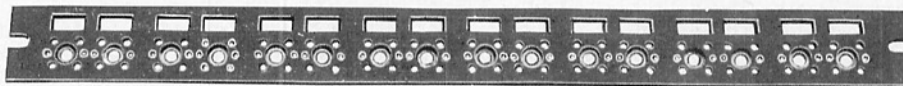

Single Row Type Mounting Strip

Single Row Type

Code No.	No. of Pairs per Strip	Length, Overall, Inches	Mtg. Centers Inches	Width Inches
1000	5	13-13/16	13-1/16	2
1011	6	16 1/4	15 1/2	2
1001	7	18-11/16	17-15/16	2
1021	7	20 1/2	19 3/4	2
1002	8	21 1/8	20 3/8	2
1003	10	26	25 1/4	2

Double Row Type

Similar to Single Row Type in construction but mounts two rows of relays.

Code No.	No. of Pairs per Strip	Length, Overall, Inches	Mtg. Centers Inches	Width Inches
1005	14	8-11/16	17-15/16	4
1004	10	13-13/16	13-1/16	4
1006	16	21 1/8	20 3/8	4
1007	20	26	25 1/4	4

RELAYS

Individual Mountings for 2000 Type Relays

Individual Mountings

Code No.	—Face—		Mounts
	High, Inches	Wide, Inches	
1012	1 7/8	2 5/8	On right side of cabinet.
1013	1 7/8	2 5/8	On left side of cabinet.
1014	2 3/8	2 1/2	On roof of cabinet.
1024	2 3/8	2 1/2	On floor of cabinet.

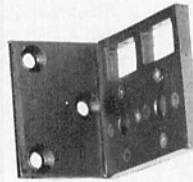

No. 1012

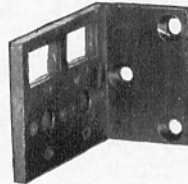

No. 1013

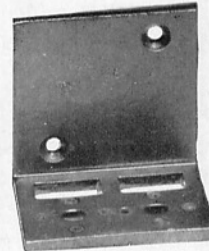

No. 1014

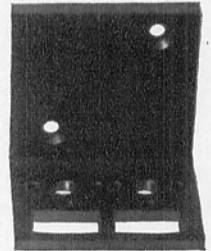

No. 1024

No. 26 Type Relays

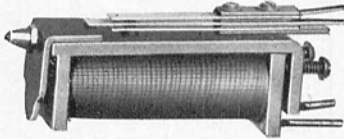

The No. 26 type relay is similar to the No. 2000 type relay in general construction but the overall dimensions are smaller.

Description	Dimension
Length Overall	3 1/2 in.
Height Overall	1 5/8 in.
Overall Length of Relay Coil	2 1/4 in.

Code No.	Spring Combination	Description	Resistance in Ohms
26-D	==	One set of make contacts.	500
561-A	== ==	One set of make contacts and three dead terminals.	500

Mounting Strips for No. 26 and No. 561 Relays

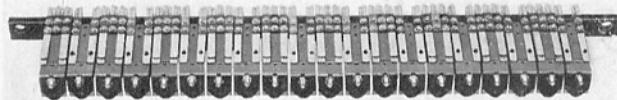

The illustration shows a mounting strip equipped with relays. Mounting strips are shipped less relays unless otherwise specified by the customer.

Code No.	Length Overall	No. of Relays per Strip	Mounting Centers	Width of Strip
375	13-13/16 in.	15	13-1/16 in.	3/4 in.
376	18-11/16 in.	20	17-15/16 in.	3/4 in.
377	26 in.	30	25-1/4 in.	3/4 in.

Polarized Relays

No. 546 Polarized Relay with Cover

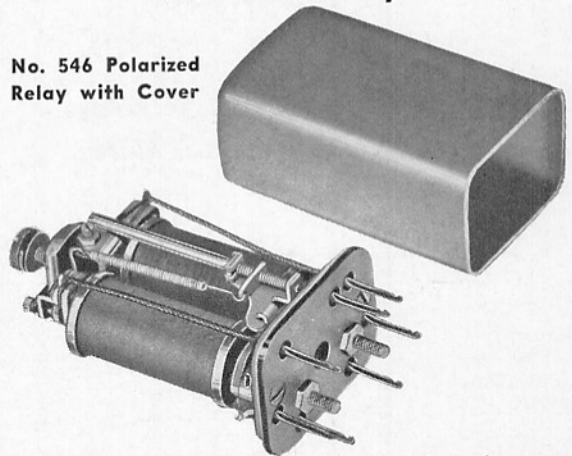

The No. 546 type polarized relay consists of two coils, a permanent magnet and an armature, similar to those used in a standard polarized telephone ringer. The relay has a make and break contact. These contacts have platinum points mounted on adjusting screws. The armature is controlled by a biasing spring with micrometer screw adjustment. These fine adjustments permit a very close setting making it possible to operate the relay continuously on closed circuit work with dry battery current.

It can be so adjusted that the current flow which holds the contact open will not re-operate the relay in case the circuit is broken and again restored. This feature is especially desirable in alarm circuits as after the circuit is broken a reconnection will not shut off the alarm.

A relay of this type has a wide variety of uses where low current consumption and extreme sensitivity is required. The shell cover for this relay is made of brass.

When ordering designate the resistance desired by adding the letter A, B, C, D, etc., to the code No. 546.

Code No.	Contacts	Resistance in Ohms			
		A	B	C	D
546	==	40	200	1600	2500
		40	200	1600	2500
546	E	3400	750	60	100
		4100 GS	750	1600	100
		15000 in Series			

Switchboard Section

SWITCHBOARD APPARATUS

2000 TYPE RELAY COILS



Relays coils are wound with copper wire unless the letters "GS", which indicate

German silver, follow the resistance value. Enamel insulation is standard. German silver wire is insulated with enamel and one wrapping of green silk, and wound non-inductive unless otherwise specified. All of the relay coils listed below are similar in appearance except for the number of terminals. They are 3-9/16 inches long and have a diameter of 1 inch.

Single Wound — With Copper Sleeves

The following single wound coils are used where a sluggish release is desired.

Code No.	Resistance	Diameter of Copper Sleeve	Code No.	Resistance	Description
S-AJ	50 ohms	1/16 in.	S-BM	500 ohms	3/8 in.
S-AK	100 ohms	1/16 in.	S-BU	1000 ohms	3/8 in.
S-AN	300 ohms	1/16 in.	S-DD*	300C-300GS	3/8 in.
S-AP	500 ohms	1/16 in.	S-FN	43 ohms	3/4 in. copper armature head
S-AQ	1000 ohms	1/16 in.			
S-AR	125 ohms	3/8 in.			

* Resistance, 150 ohms in multiple

Relay Coils for 2000 Type Relays Single Wound — 3/8 inch Core

Code No.	Resistance	Description	Code No.	Resistance	Description
S-D	10 ohms		S-FG	800 ohms	12200 turns with No. 36 wire
S-E	20 ohms		S-W	1000 ohms	14200 turns with No. 36 wire
S-F	30 ohms		S-FY	1000 ohms	11000 turns with No. 38 wire
S-H	50 ohms		S-X	1500 ohms	
S-J	65 ohms		S-Y	2000 ohms	
S-BL	70 ohms		S-Z	3000 ohms	
S-GL	75 ohms		S-BG	4000 ohms	
S-L	100 ohms				
S-M	125 ohms				
S-N	150 ohms				
S-P	200 ohms	7500 turns with No. 32 wire			
S-FP	200 ohms	4950 turns with No. 35 wire			
S-R	300 ohms	Used in cut-off relays			
S-DZ	300 ohms	Ratchet Adj. Arm			
S-U	400 ohms				
S-V	500 ohms				
S-DG	800 ohms	13740 turns with No. 35 wire			

Single Wound — 1/4 inch Core

Code No.	Resistance	Description	Code No.	Resistance	Description
S-EQ	1.5 ohms	Used on pilot relays, 24 volts	S-ET	140 ohms	
S-EB	4.5 ohms	Used on pilot relays, 48 volts	S-EP	3800 ohms	
S-EA	7.47 ohms		S-EK	7250 ohms	
S-HY	100 ohms		S-FV	14500 ohms	
			S-EM	16C—45GS	Total resistance, 61 ohms

Concentric Wound — 3/8 inch Core

Code No.	Resistance	Description	Code No.	Resistance	Description
C-P	1000	525C & 475GS connected in series to terminals No. 1 & No. 2.	C-AW	500C — 20GS	
	1000GS		C-AH	500C — 100GS	
			C-CR	500C — 200GS	
			C-AE	500C — 300GS	
			C-AB	500C — 500GS	
C-BX	50C — 50GS		C-EA	775C — 250GS	Sterling varnish.
C-FC	65C — 20GS		C-EY	850C — 1100GS	Inductive.
C-CC	150C — 750GS	Inductive.	C-EQ	1000C — 100GS	
C-AM	300C — 300GS		C-AJ	1000C — 500GS	
C-DG	300C — 1700GS	No. 4 terminal is dead.	C-DP	1000C — 1000GS	

Concentric Wound — 1/4 inch Core

Code No.	Resistance	Description	Code No.	Resistance	Description
C-EZ	31C—750GS		C-EP	100C, 8875C — 3125GS	12,000 ohms
C-DF	875C—200GS				
C-DR	875C—450GS	Rough Wound			

Concentric Wound — With Copper Sleeves

Code No.	Resistance	Description	Code No.	Resistance	Description
C-CY	125C—130GS	3/4 inch solid copper armature head, inductive.	C-Z	500C—500GS	1/16 inch copper sleeve-inductive.
			C-BZ	1000C—500GS	1/16 inch copper sleeve.

Tandem Wound — 3/8 inch Core

Code No.	Resistance	Description	Code No.	Resistance	Description
T-J	50- 50		T-Y	1000-1000	
T-Z	75- 75		T-AH	100- 300	
T-C	100- 100	48 volt cord circuit	T-AY	300- 100	
T-U	150- 150		T-BX	490- 48	
T-G	200- 200		T-E	500- 100	
T-F	500- 500		T-H	500- 250	

Tandem Wound — 1/4 inch Core

Code No.	Resistance	Code No.	Resistance
T-BL	35- 35	T-CW	48-641
T-BK	46- 46	T-BY	125-125

Tandem Wound — With Copper Sleeves

Code No.	Resistance	Description	Code No.	Resistance	Description
T-CL	1000- 20	1/16 inch copper sleeve	T-AB	1000-500	1/16 inch copper sleeve

2000 TYPE RELAY COILS

2000 Type Relay Coils, Wound Non-Inductive

Used for Resistance Coils

Single Wound — 3/8 inch Core

These coils are wound throughout with German silver wire insulated with enamel and one wrapping of silk.

Code No.	Resistance	Code No.	Resistance
S-DJ	50 Ohms	S-CB	500 Ohms
S-CE	100 Ohms	S-CS	750 Ohms
S-GJ	150 Ohms	S-FQ	800 Ohms
S-CT	200 Ohms	S-CD	1000 Ohms
S-CQ	250 Ohms	S-CR	1200 Ohms
S-CC	300 Ohms	S-CJ	2000 Ohms
S-CV	400 Ohms	S-CH	10,000 Ohms

Tandem Wound — 3/8 inch Core

Code No.	Resistance	Code No.	Resistance
T-AV	50-50 Ohms	T-CN ...	2000-2000 Ohms
T-AT	200-200 Ohms	T-CJ ...	3000-3000 Ohms

Miscellaneous Relay Coils

Coils for No. 600 Type Relay Single Wound

Code No.	Resistance
S-DP	300 Ohms
S-DM	1000 Ohms

Note: Neither No. 600 Type Relay nor the mountings for this relay are shown in this catalog but they are available on order.

Relay Coils Used for Revertive Ringing Tone — Single Wound

Code No.	Resistance in Ohms
S-FC	540
S-GB20—.28 mf.—100 GS.
S-GT01—mf.—10,000 GS

Battery Feed Coils for Intercommunication Systems — Concentric Wound

Code No.	Resistance in Ohms	Remarks
C-MG	25 - 25	Same as No. 14-C Retd. Coil
C-MA	50 - 50	Same as No. 14-F Retd. Coil
C-MB	100 - 100	Same as No. 14-B Retd. Coil
C-MF	250 - 250	Same as No. 14-A Retd. Coil

Note: These coils also are shown under Retardation Coils in this catalog.

No. 36 Type Relay Coil

Type No. 36 is used in cordless switchboards.

Code No.	Resistance
S-MG	500 Ohms

Relays for Kellogg Relaymatics

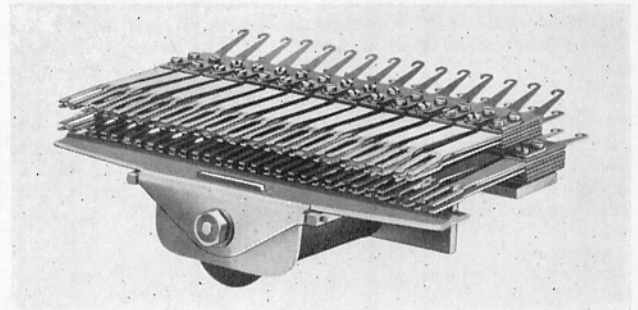

No. 7000 Type Gang Relays

Kellogg relays are simple, rugged and reliable — the result of over 40 years' experience.

All relays used in Kellogg Relaymatics have twin contacts. This feature provides a broad margin of safety because the extra contact on each relay practically eliminates every possibility of failure. Because of these twin contacts, the best service is assured with minimum maintenance.

Precious metal is used on all relay contacts which means quieter operation and increased dialing range. By employing such special metal as this, good connections are assured. This is particularly important on toll connections.

In designing these relays, Kellogg engineers provided another feature that is equally important in assuring perfect connections. The armature is arranged so that even after the relay contacts are closed, there is some armature travel. This action has a cleaning effect which removes dust that may have settled on the contact.

The relay springs are made of a special nickel silver. This alloy was adopted because it is highly flexible and maintains its tension. Special Bakelite insulation is used throughout because of its insulating qualities and because it is least affected by moisture, temperature variations, contraction and expansion.

The relay springs are made of a special nickel silver. This alloy was adopted because it is highly flexible and maintains its tension. Special Bakelite insulation is used throughout because of its insulating qualities and because it is least affected by moisture, temperature variations, contraction and expansion.

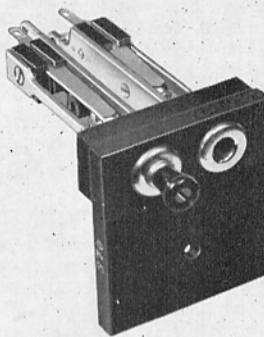

Combination Test Jack and Switch No. 370

No. 370 is used with switchboard plug No. 106 on Relaymatic boards. It consists of two No. 260 spring jacks mounted on a Bakelite panel. One jack is equipped with a push button plunger. The face of the strip is 2-3/16 x 1-15/16 inches in size. One of these units is used with each connecting link of a Relaymatic switchboard.

No. 372

No. 372 jack is the same as No. 370 but is equipped with mounting bracket No. 62679.

Switchboard Section

SWITCHBOARD APPARATUS

KELLOGG REPEATERS

The Kellogg repeater is designed and built to fill the needs of independant telephony, railroads, pipe lines, power companies, and other users of long line communications. It is a practical piece of equipment for dependable operation without adjustment regardless of time or weather. It is designed simply, built ruggedly and compactly assembled.

The Kellogg repeater has power. It will overcome the loss in 157 miles of .104 copper, 13.5 miles of No. 19 B. & S. gauge cable, or 8.3 miles of No. 22 B. & S. gauge cable. These figures are altered somewhat by various conditions, but are close enough for an illus-

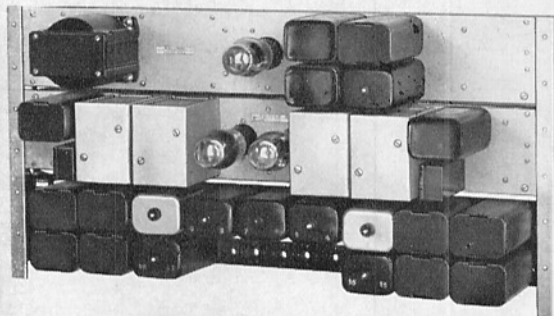

Kellogg Telephone Repeater. The top panel mounts the power unit, the middle panel, the repeater unit and the bottom panel mounts the line unit.

tration of how the repeater can span distance. And, of course, other repeaters can be added along the route to extend the circuit farther and farther.

This repeater not only produces volume and power, it reduces noise and distortion arising from other sources. The Kellogg repeater is remarkably stable. The operator has no control of the repeater gain, hence errors from that source are eliminated. The Kellogg system of gain control has a notable stabilizing effect which is a big help on circuits of a variable nature. For this reason, Kellogg repeaters can be operated satisfactorily on dispatching wires and other circuits having branches and intermediate stations.

The Kellogg repeater and power unit contain no moving parts with the exception of relays which may be used. All tubes are standard radio tubes. Coils are wound with wires of substantial size and are thoroughly impregnated. The power transformer is designed for 100% overload and consequently will not heat in continuous service.

The Kellogg repeater as a unit is adaptable to any type of service and may be used as an intermediate line, terminal or cord repeater.

The illustration shows the general style of Kellogg repeater equipment, assembled in standard form on strips for relay rack mounting. The upper mounting strip contains the power equipment, including the power transformer, rectifying tube, filter equipment and an automatic emergency-battery switching relay if one is used. The two bottom strips contain the repeater equipment proper. Relays and repeating coils for ringing equipment are mounted on the bottom strip. Below these panels, a testing and patching panel may be added. Overall can covers fit over this equipment for protection.

The power unit used with this repeater is designed to operate from 115 volt, 60 cycle, single phase, alternating current. It may however be supplied for operation on other frequencies and other voltages but each unit must be used on current of the voltage and frequency for which it is designed and adjusted.

As insurance against interruption of service by reason of failure of the commercial current, a throw over relay is provided if specified, as a part of the power unit to automatically switch the repeater from the power unit to emergency batteries.

Kellogg repeater equipment is assembled on mounting plates for use on a 19-inch or 27-inch rack or for mounting in a cabinet. Both racks and cabinets are available. On the 27 inch rack, the vertical space required is 12-inches and on the 19-inch rack, 26-5/32 inches.

Complete equipment for various installations include a Repeater Unit, a Power Unit, one of the Line Units described below and the miscellaneous equipment listed below.

Repeater and Power Units

Code No.	Description	Mounting	Height of Panel
1	Repeater Unit	27-inch Rack	4 in.
2	Repeater Unit	19-inch Rack	8-23/32 in.
101	Power Unit	27-inch Rack	4 in.
102	Power Unit	19-inch Rack	8-23/32 in.

Line Units

The power and repeater units are the same on all installations but line units are assembled, equipped and wired as required. Line units are available to mount on either the 19 or the 27-inch rack.

This type of an assembly permits furnishing exactly what is required for a particular installation. This makes it unnecessary for the user to buy a repeater set with equipment making it adaptable to a large range of circuits when it is to be used on only one type of circuit. Although a number of "standard" line units to fit most installations have been designed, wiring and assembly at the time of the order makes it possible to make any necessary changes or additions to fit the particular installation.

Standard line unit assemblies are:

INTERMEDIATE LINETYPE, low frequency by-pass (3½—20 cycle).

INTERMEDIATE LINETYPE, with 20 cycle relay ringing by-pass.

TERMINAL TYPE.

CORD TYPE. One is required for each line on which the repeater is to be used. In addition to the line unit, cord type installations require repeater cord circuit unit, jack and lamp terminating equipment in the switchboard.

Miscellaneous Equipment

This miscellaneous equipment, furnished with each repeater installation includes:

A set of **SPARE TUBES** for the whole installation.

A set of **MAINTENANCE TOOLS.**

A **RACK** or **CABINET**, if required.

SWITCHBOARD GENERATORS

The secret of the Kellogg generator's extraordinary strength lies not only in its permanent magnet, but in the superior design of its revolving electro-magnet or armature upon which the wire is wound.

All generator parts are well protected from rust and corrosion. Magnets are given a heavy coating of special blue paint. The gear, pinion, shaft field and screws are all nickel plated, dull finish.

No. 72 generator mounts from the bottom and No. 63 is the same as No. 72 except the mechanism is inverted in the magnets.

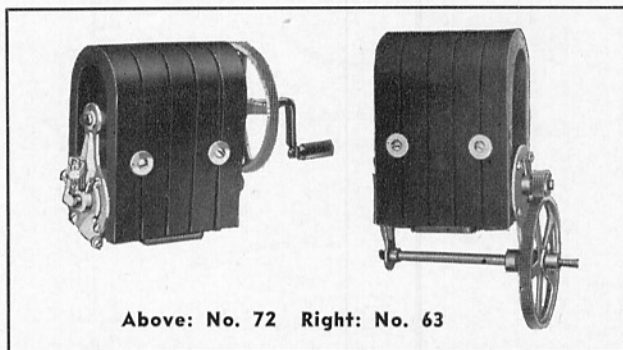

Above: No. 72 Right: No. 63

For Alternating Current

Code No.	No. of Bars	Height	Depth	Width With Handle
72	5	5 1/2 in.	4 in.	8 1/4 in.
63	5	8 1/2 in.	4 in.	8 1/4 in.

Major Parts







No. 63 Generators			No. 72 Generators		
No of Pieces	Piece Part No.	Description	No of Pieces	Piece Part No.	Description
1	15911	Crank Assembly	1	15911	Crank Assembly
1	12974	Armature Assembly	1	12974	Armature Assembly
1	42679	Spring Assembly	1	12172	End Bracket Assembly
1	29034	End Bracket Assembly	1	12175	End Bracket Assembly
1	29035	End Bracket Assembly			

Generator Extension Shafts

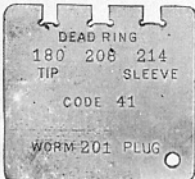
Used With Pc. No. 15911 Generator Cranks.

Code No.	Length
9	24 in.
14	12 1/4 in.
17	20-1/32 in.

TOOLS

Lamp Cap Extractors	Gauges	Miscellaneous
 No. 24	 No. 40	 No. 21
 No. 38	 No. 48	 No. 22
		 No. 42

Lamp Cap Extractors

Code No.	Description
24	Supervisory lamp cap extractor.
25	Steel lamp extractor for 7/16 inch jacks.
27	Fibre lamp extractor.
38	Line lamp cap extractor.

Gauges

Code No.	Description
40	For gauging worn No. 106, 137 and 156 plugs.
41	For gauging worn No. 201 plugs.
46	For gauging worn No. 152 plugs.
47	For gauging worn No. 112 and 187 plugs.

50	For gauging worn No. 42 plugs.
48	For gauging worn No. 239 type jacks.
49	For gauging worn No. 258 type jacks.
51	For gauging worn jacks taking the No. 42 plug.

NOTE: All plug gauges are furnished with strong leather cases.

Miscellaneous

Code No.	Description
21	Small board screw driver.
22	Screw driver for hollow screws on plugs.
42 ¹	Tool for skinning switchboard cable.
62 ¹	Plug seat burnishing tool.
65	Tool Kit. Consists of a No. 61 tool, a No. 62 tool and a No. 54140 holder. For drilling .368 in. plug seats.
68	Contact cleaning tool.

Switchboard Section

SWITCHBOARD APPARATUS

TOOLS

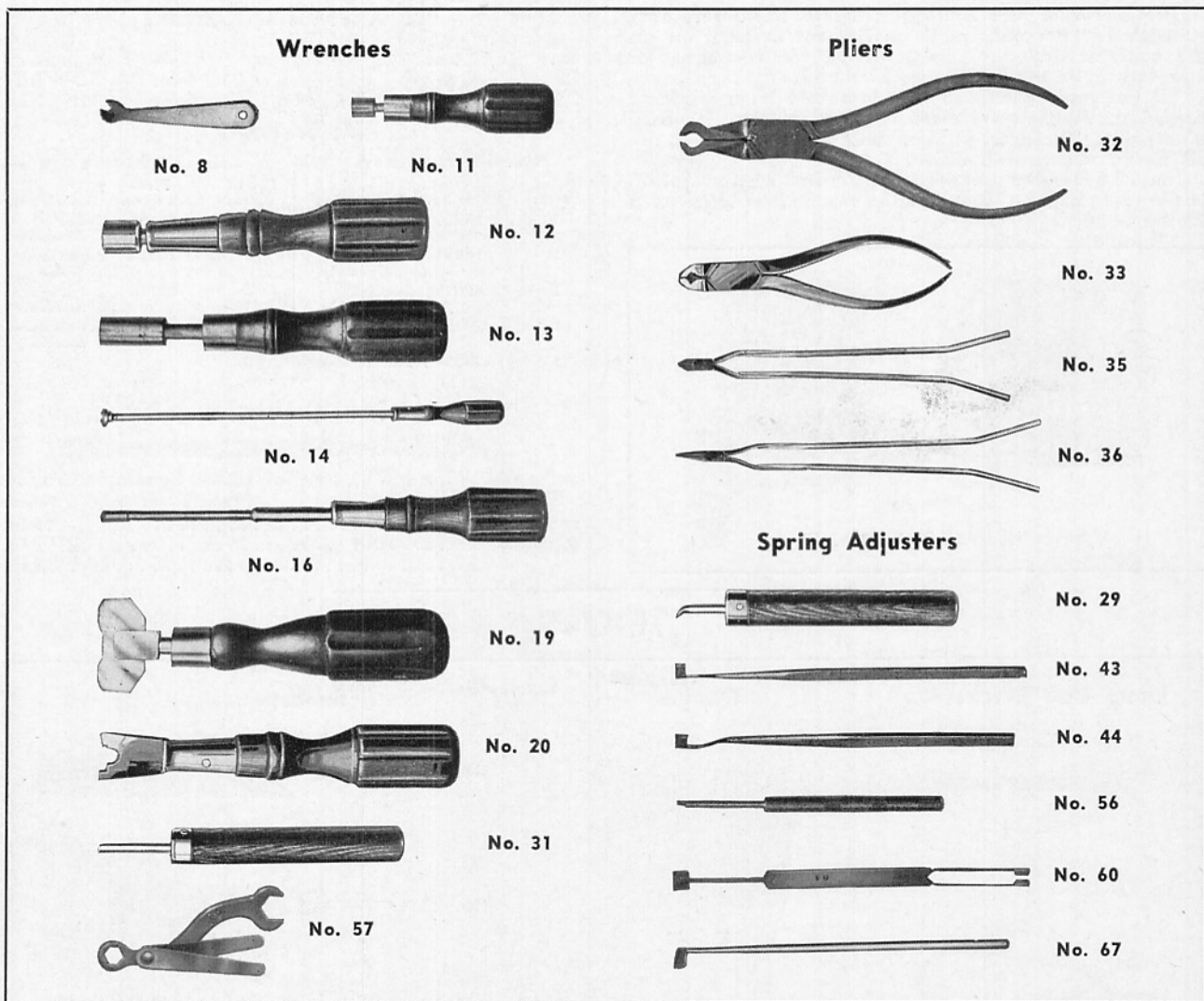
**Wrenches**

Code No.	Description
8	Flat wrench for adjusting drop armatures.
11	Socket wrench for relay armature nuts — also for arrester nuts.
12	Socket wrench for sleeve of combination drop and jack and for 72 relay shell, hexagonal nut.
13	Socket wrench for mounting major relays on mounting strips.
14	Socket wrench for fastening jacks in switchboard with Pc. No. 989 nuts.
16	Socket wrench for stop nuts on No. 1000 type cam keys.
17	Socket wrench with adjustable feature for No. 989 nuts for switchboard jacks.
18	Socket wrench for nuts on relay gate.
19	Wrench for removing No. 22 type major relay shells.
20	Screw driver wrench for removing No. 72 type major relay shell with round nut.
31	Wrench for regular size removable sleeve of jacks.
57	For adjusting No. 555 relay on Nos. 6 and 7 converters.

Pliers

Code No.	Description
32	Pliers for removing heat coils.
33	Pliers for removing 4-party key buttons.
35	Long handle diagonal Swedish cutters.
36	Long handle, long nose chain pliers.
39	Pliers for placing terminals on tinsel cords.

Spring Adjusters

29	Adjusters for tip springs on No. 116 type jacks.
43	Relay spring adjuster, right hand bend.
44	Relay spring adjuster, left hand bend.
56	For bending and adjusting springs in spring jack.
58	Double ended spring adjuster.
60	Relay spring adjuster — special construction to adjust center or B spring assembly.
67	Key spring adjuster.



KELLOGG

Telephones and Piece Parts

GENERAL CATALOG NO. 10

Ordering Information.....	Page 2	Railway and Special Telephones.....	Page 30 to 31
Masterphones, General.....	3 to 17	Portable and Weatherproof Telephones.....	32 to 33
Masterphones, Common Battery — Dial or Manual	3 to 23	Telephone Accessories.....	34 to 36
Common Battery Telephones.....	24 to 26	Conversion Kits.....	37
Magneto Masterphones.....	27 to 29	Telephone Parts.....	38 to 46
		Index.....	47 to 48

KELLOGG SWITCHBOARD AND SUPPLY COMPANY

Factory and General Offices: 6650 S. CICERO AVE., CHICAGO, ILL., U. S. A.

Branch Offices . . . 308 W. Sixth St.
Kansas City, Mo.

246 First Street
San Francisco, Calif.

Telephone Section

CUSTOMER INFORMATION

Guarantee

Through the years Kellogg has established with its customers, the reputation of selling goods that give a full measure of satisfaction. Further, all goods properly used are fully guaranteed for one year against any defect in material or workmanship and are subject to replacement.

Always notify us before making any return shipments. This will help to make the proper adjustment without delay.

Terms

Terms are 30 days net from date of invoice except for some items of construction material which carry a discount for cash within ten days from date of invoice. These terms are shown on invoices.

Charge accounts are invited. New customers who may not be rated by the commercial agencies can help assure prompt service by sending credit information with initial orders. Sight draft or C.O.D. orders receive the same immediate attention as those covered by established charge accounts.

Orders

To avoid errors or delays, catalog numbers as well as the name of each article should appear on the order. Possibilities of delay are decreased when complete information is given in the order.

Telephone or telegraph orders should be confirmed by mail immediately so that if a mistake is made in transmission of the order it can be checked and corrected. However, confirming orders must be marked "Confirming" to avoid the possibility of duplication.

Changes and Cancellations

A reasonable charge is made for changes or cancellation of orders when engineering, special assembly or adjustment is involved. These charges are only sufficient to compensate for the actual loss in time or material.

Shipments

Always specify whether goods are to be shipped via freight, express or parcel post. When shipment is desired by freight please specify the routing. In

the absence of instructions we shall use our best judgment in selecting routes which will assure the best service.

Claims for Shortage, Breakage or Non-Delivery

All claims for breakage, damages and non-delivery should be made without delay to the transportation company handling the shipment. We will gladly assist in presenting these claims.

Receipts from the transportation company specify that shipments are received in good condition, therefore shipments must be checked as they are received. Always have the agent of the transportation company make a notation on the bill of lading specifying any damage or shortage.

If packages or cases are in apparent good order, but contents are found to be damaged upon opening, call the freight agent or adjuster and have him mark the freight bill to show the concealed damage.

Claims for damage or non-delivery of parcel post shipments should be made to us as we insure this material and make all adjustments.

Returning Goods

Please notify us before making any return shipments. This will help to make the proper adjustment without delay.

The liability of the Kellogg Company is limited in all cases to the value of the goods claimed to be defective.

Marine and Parcel Post Insurance

Unless otherwise directed, we shall insure against non-delivery all shipments made by steamer or parcel post. A nominal charge will be made to cover the cost of this service.

Specifications

Statistical information contained in this catalog pertaining to strength and proper working loads of materials, tools, etc., is derived from tables compiled by the manufacturer and is reprinted for the convenience of the buyer.

KELLOGG TELEPHONES

Kellogg telephones have attained an enviable reputation for having the finest transmission and reception. This dominant advantage, and the superiority it gives users of Kellogg telephones is, in a measure, responsible for the fact that thousands of companies throughout the world have standardized on them. Kellogg has successfully held this prominent position of leadership in the industry for nearly half a century by constant research and pioneering; through ability to foresee the needs of the telephone industry and being able to fill these needs.

Kellogg telephones have always played an important part in the advancement of Telephony. They are today the recognized standard for transmission and reception. They are dependable and trouble-free. Kellogg telephones are simple in design and ruggedly constructed . . . manufactured with care and precision. They require practically no maintenance attention and assure satisfactory service for many years.

Throughout the history of the telephone industry, Kellogg's pioneering has been outstanding. Among the many vitally important things that Kellogg introduced to the manufacturing branch of this industry was that

of plastics. It installed one of the very first plastic molding plants in the United States. Kellogg telephones were the first to make use of Bakelite and other similar materials.

Today, plastics are as universally necessary to good telephone construction as are gold, silver, nickel, steel, copper and the other metals and materials essential to the production of high quality communication apparatus. That others continued to follow Kellogg's lead in major developments proves again and again that this leadership is maintained by the same pioneering instinct and complete understanding of telephony that first brought recognition to Kellogg products in the early days.

This leadership in design and construction is further illustrated by the present efficiently constructed Kellogg Masterphones. These telephones are practically unbreakable, parts are easily accessible and a screw driver is the only tool necessary to remove any part.

In its modern, million dollar plant, Kellogg manufactures a complete line of telephones and apparatus, built to the highest efficiency standards. Whenever Kellogg telephones are given the opportunity to perform, they prove to be the finest instruments that money can buy.

Kellogg NON-POSITIONAL Transmitters

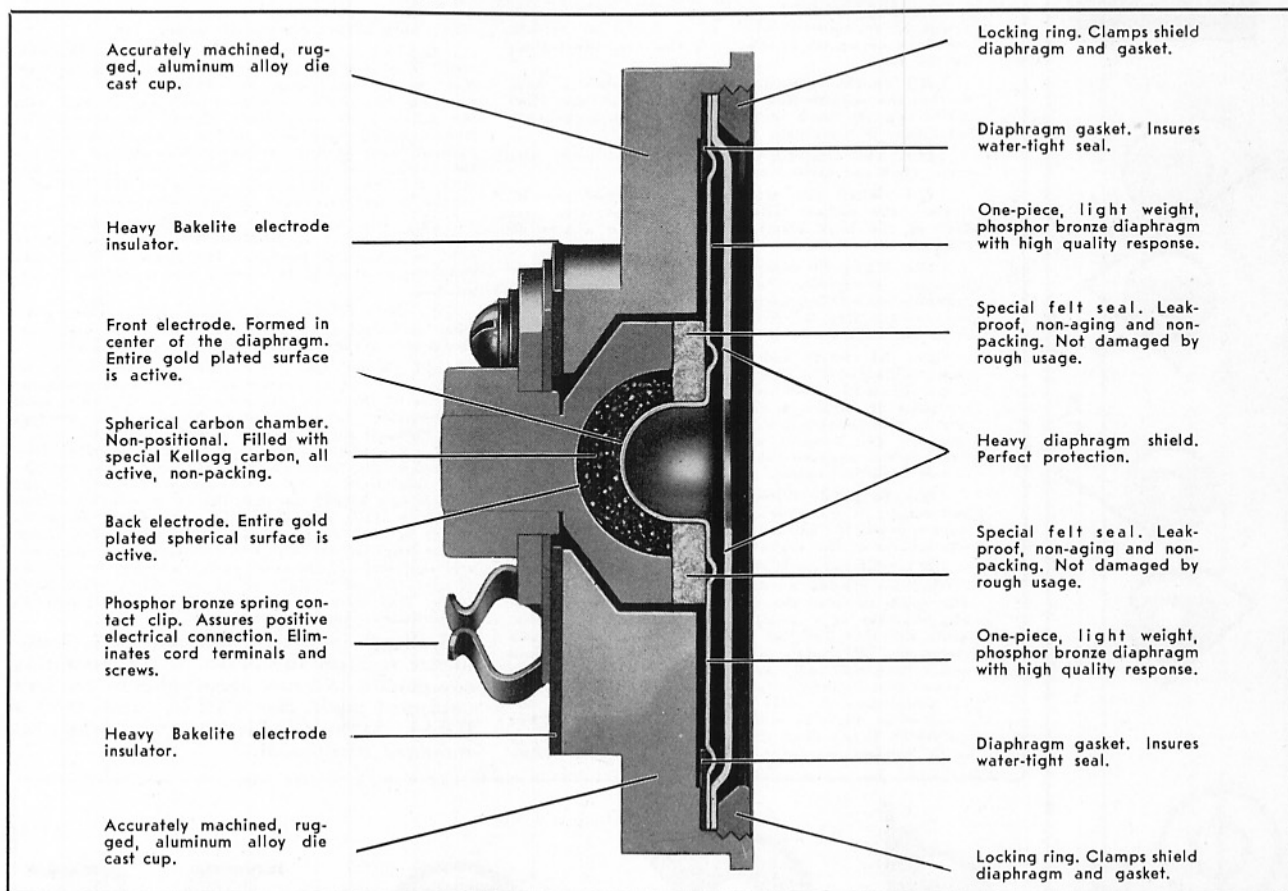

Kellogg NON-POSITIONAL transmitters are especially designed to give the best transmission under modern operating conditions. Because of the patented, spherical shape of the carbon chamber there can be no "dead" talking positions to limit or restrict subscribers in the way in which the modern telephone must be held. These compact, self-contained NON-POSITIONAL transmitters

have also established new higher standards of transmission efficiency.

They come with all Kellogg Masterphones and can be adapted to all Kellogg desk stands and old type standard wall sets. Likewise, they can be used with suspended type operator's sets, and smaller units come as standard equipment in breastplate sets.

Kellogg NON-POSITIONAL Transmitter

KELLOGG was the first manufacturer to recognize that popular use of the handset had created a new problem. Now, a transmitter is never stationary . . . or even nearly so. It may be used at any angle, in any position. Therefore, the old, conventional transmitters would go "dead" when tipped beyond the limits of a vertical plane. The only answer was to develop a transmitter which was fully NON-POSITIONAL and which was rugged enough to stand the rougher usage.

Kellogg did this shortly after the original Masterphone was first introduced. It was a distinct, new development, the first of its kind since the advent of the handset. This patented, spherical electrode construction is exclusive with the Kellogg NON-POSITIONAL transmitter and comes as standard equipment in all Masterphones without extra charge.

So that equal transmission may also be available in other types of Kellogg telephones and so that operating companies can standardize on one transmitter throughout, Kellogg developed a combination Bakelite transmitter front and mouthpiece unit for deskstands and wall phones employing the standard Masterphone NON-POSITIONAL transmitter.

The How and Why of This Great Development

What happens in the carbon chamber of any conventional transmitter when it is tipped at various positions or angles is shown by the first illustration on the left.

(A) In the vertical position the carbon is held so that the current flow between the diaphragm electrode and the back electrode is gauged to provide maximum transmission.

(B) The transmission remains practically the same when the carbon cup is tilted.

(C) When the transmitter is tipped on its "face", the carbon falls away from the large surface of the back electrode, resulting in a loss of efficiency.

(D) When the transmitter is laid on its back it becomes practically "dead", because the carbon granules have fallen away from the diaphragm which reduces the flow of current between the back and front electrodes.

Since subscribers will use their handsets in every conceivable position, and since the conventional transmitter obviously does not function uniformly in all positions or angles, a new type of transmitter of a strictly non-positional character had to be developed expressly for handset use. How this all-important problem was approached and solved by the engineers is now to be explained.

(E) By partly filling a hollow ball with carbon and rolling it up, down, or sidewise, the carbon always contacts the same amount of inner wall, and the top surface of the carbon is always level.

(F) The hollow ball idea is now carried a step further by placing a smaller ball within the larger. The space between the two represents the ideal carbon chamber of a strictly non-positional transmitter, while the side walls of each ball represent the two electrodes. By partly filling the space with carbon and rolling this ball over and over we find that the carbon is constantly in contact with the same amount of wall space of each electrode, regardless of the position or angle in which the ball is tipped. This, naturally, is the ideal arrangement for a carbon cup in a handset transmitter because the current flow

would always be steady and uniform, and transmission would always remain the same.

(G) This illustrates how the "ball-within-the-ball" idea is used, practically, in designing the carbon chamber of a true NON-POSITIONAL transmitter. The two balls have now been cut in half with the walls of the inner ball slightly lengthened. The flanges which have been added make it possible to control, with extreme accuracy, the spacing between the surfaces of the balls. Thus, when an insulated ring is inserted between the flanges of the ball electrodes, a perfect carbon chamber is formed.

(H) This illustration shows the completed carbon chamber of a NON-POSITIONAL transmitter held in a vertical position. The space is filled with the proper amount of carbon for maximum transmission.

(I) By revolving and tipping it to various positions and angles we find that the carbon maintains uniform coverage of both electrodes at all times.

(J) When this transmitter is tipped on its "face", the carbon cannot fall away from any large portion of the back electrode, and as a result, good transmission is maintained because the current flow between the electrodes remains constant. (K) Due to the front electrode being a spherical hollow formed in the center of the diaphragm itself, and the back electrode a spherical hollow formed in the carbon cup block, the granules in the chamber uniformly contact both electrodes even when the transmitter is laid on its back. Thus we have a transmitter that is strictly non-positional in character, and operates at highest efficiency whether it is on its "back", on its "face", or at any other position or angle. The current flow, at any and all positions, is continuous and positive.

Kellogg engineers developed this transmitter to meet the needs of the operating companies. All new Masterphones are now equipped with the FIRST and ONLY REAL NON-POSITIONAL transmitter as standard equipment.

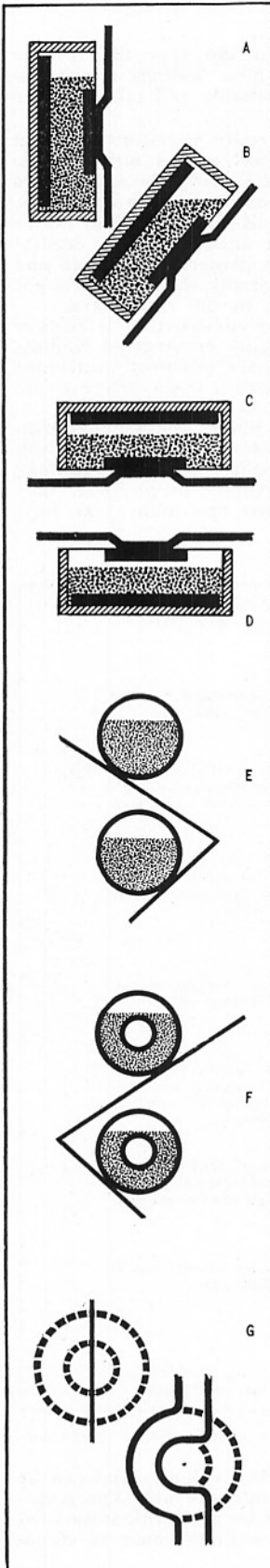

Kellogg NON-POSITIONAL Transmitter

The illustrations on this page show a graphic comparison, in terms of transmission, between the conventional or "fixed position" transmitter and the Masterphone NON-POSITIONAL transmitter. These charts show the degree of improvement of the NON-POSITIONAL type over the old style in transmission volume, response at various positions, voice frequency range, articulation, and understandability.

The first chart indicates the "rough" or "uneven" response produced by the conventional transmitter when it is revolved. In its normal position, indicated by the solid line, the transmitter response is very poor below 1,000 cycles and above 2,700 cycles. When the transmitter is tipped on its "face", the dot and dash curve records a highly irregular response, reaching peaks only around 1,200 and 2,000 cycles. The dotted line shows a very ragged response throughout the range when the transmitter is on its "back", and shows a radical drop of a minimum of approximately 10 decibels.

Subjecting the NON-POSITIONAL transmitter to the same test and revolving it in the same manner we find that the curves recorded on the second chart are uniform for all positions. The solid line represents the transmitter in its normal or vertical position; the dot and dash curve shows the transmitter on its "face"; and the dotted line, when the transmitter is on its "back". The character of these curves indicates the uniformity of transmission of the NON-POSITIONAL transmitter as contrasted with the highly irregular curves of the conventional or "fixed position" transmitter shown on the upper chart. The fact that all three lines of chart two take the same curve, proves that this transmitter is strictly a NON-POSITIONAL unit.

The third chart shows the difference in range of frequency response between the old style transmitter and the NON-POSITIONAL unit. Since frequency response is the measurement of a transmitter's ability to reproduce faithfully all of the vibrations of the human voice, we see here the volume of sound reproduced at any given vibration, expressed in frequencies or cycles per second. Because all tones below 280 cycles and over 2,500 cycles are not recorded by the old style transmitter, articulation is seriously impaired for the human voice goes beyond these limits. Considering that the NON-POSITIONAL unit actually covers a frequency range of from 200 cycles to 3,500 cycles, a general improvement in articulation is a natural result and therefore provides clearness, naturalness, and understandability to a far greater degree. In addition, the NON-POSITIONAL transmitter has a much more even response over the full voice range. This is especially true of high frequencies or higher voice tones, which the old type transmitters failed to reproduce with fidelity, and which are all important if the transmitted voice is to sound natural.

The reproduction of all tones within the range of the NON-POSITIONAL transmitter not only assures good articulation, but its degree of improvement, when measured scientifically in testing laboratories, is shown as being at least 15% over that of the older types. Chart Number 4 conveys this idea graphically to show the quality of reception of the NON-POSITIONAL transmitter as compared to that of the conventional type. A transmitter with poor articulation brings the voice to the receiver fuzzy and distorted. The NON-POSITIONAL transmitter, on the other hand, brings the naturalness of a face-to-face conversation. This condition does not necessarily mean greater volume of sound, but it does mean that more of the frequencies or sound waves of the human voice, plus the overtones or harmonics, are transmitted with fidelity, and this makes for clear, crisp and distinct reception of the natural voice.

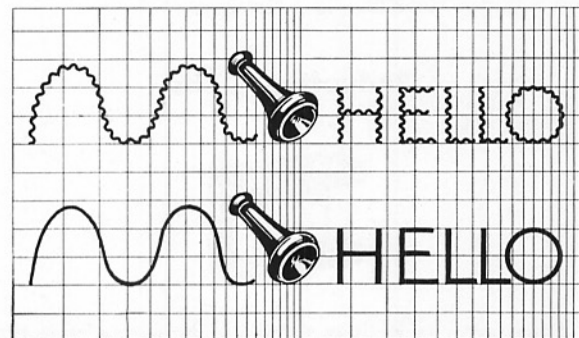
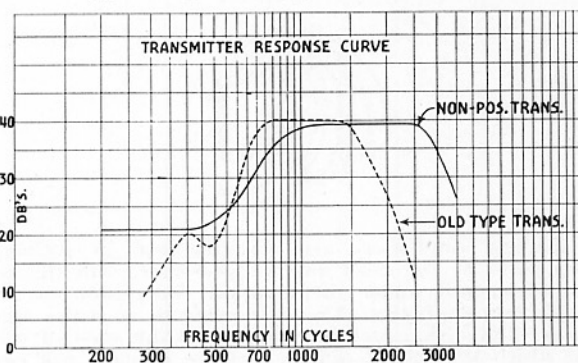
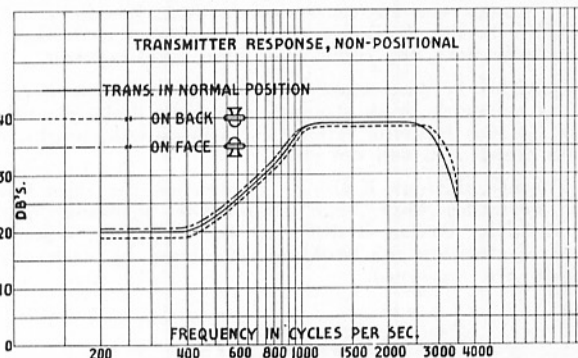
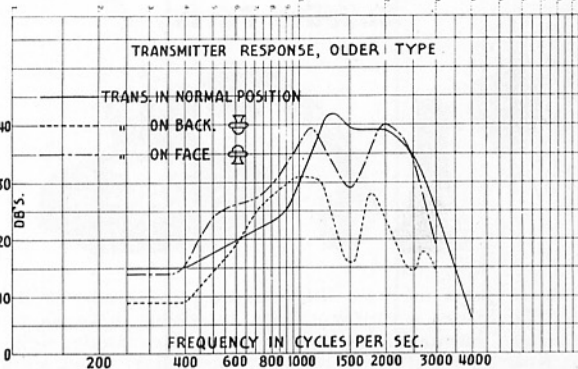

Kellogg Receivers

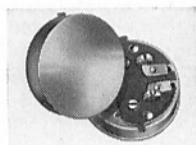

The design of Kellogg compact, self-contained receivers secures a uniform clearness of tone and accurate articulation. The diaphragm is cadmium plated, of the proper thickness and is always

held in the correct position to respond freely and accurately to the voice currents. Kellogg Masterphone receivers are of the standard bi-polar type, using cobalt magnets which have more magnetic saturation and longer life.

Telephone Section

Parts Used In Kellogg Masterphones

Bakelite Parts



Many parts used in Masterphones are made of Bakelite. To insure a uniform high standard, these parts — housings, handsets, bushings, etc. — are made right in the Kellogg plant. The processes used have been worked out through the 25 years that Kellogg has been using Bakelite in the manufacture of telephones — longer incidentally than any other telephone manufacturer.

Bakelite is particularly suited to this work because of its extremely high strength and high dielectric value, and because Bakelite retains its satin-smooth, bright, durable finish and will not chip.

Further, through Kellogg's experience, the right Bakelite formulas have been found for particular parts. That is, by having a different Bakelite mix, suited to each application the problems presented by each application are answered.

Condensers



Kellogg condensers are manufactured in Kellogg's own plant by the most modern processes, with the best materials, and under the constant supervision of Kellogg's own engineers. They are made to meet the maximum voltage that may be required in the class of work for which they are designed, and are modern and compact with no sacrifice in efficiency.

Induction Coils

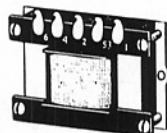

A big factor in Kellogg circuits is the design of Kellogg induction coils. The windings of these induction coils are of the proper resistance and balance, permitting sufficient current to carry over long distance lines without distortion, and yet not reduce the strength of the incoming voice currents.

Adjustable induction coil resistance is provided to allow maximum transmission on low battery current and minimum sidetone on short loops.

Ringers

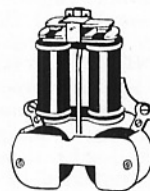

Kellogg ringers have extreme sensitivity and efficiency. Even under adverse conditions when available ringing current is at a minimum, Kellogg ringers respond where others fail.

These ringers are pleasant to hear, with a tone of great carrying power. This performance is due to different balance, new materials from frame to core and new type of gongs and gong suspension.

Kellogg ringers meet every requirement. Ringing may be either metallic or grounded. The biased type ringer is furnished for single party metallic ringing, for code ringing, or for two party divided grounded ringing. The harmonic type is furnished for multi-party, metallic ringing and for divided ringing.

Cords

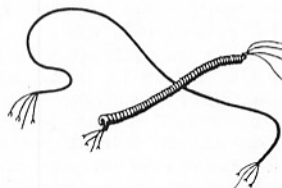

A part of Kellogg's leadership in the manufacture of telephones is due to the high quality cords manufactured right in Kellogg's plant. Here, enormous facilities, modern machines, skilled, experienced operators and close supervision combine to insure Kellogg cords of all kinds being the best obtainable. Kellogg's modern laboratory is constantly developing new and better materials and finding improved methods of manufacture and construction. All of these factors keep Kellogg cords uniformly superior.

Switch Assemblies

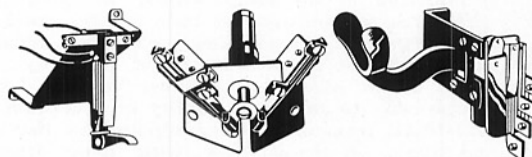

There are three types used in Kellogg telephones, the plunger-switch, hook-switch and trigger-switch. Each type was developed for a particular application and all three furnish positive action and consist of simple, rugged assemblies.

All desk Masterphones feature the plunger-switch. The long, resilient, rugged springs always make positive contact and are easily adjusted.

Wall Masterphones employ the trigger-switch. Its construction guarantees free and easy operation. Long leaf springs make for positive contact and simple adjustment.

The simple, sturdy design of Kellogg hookswitches make them highly efficient. They are of the short, compact type with removable hook, and are used on steel and wood wall sets and desk stands.

Kellogg TRIAD Circuit

Kellogg Circuits

Kellogg talking circuits are designed in connection with the Kellogg transmitter, receiver and induction coil for maximum transmission and reception. These circuits are simple and efficient. The ringing circuits are also designed for the greatest efficiency.

Kellogg TRIAD Circuit

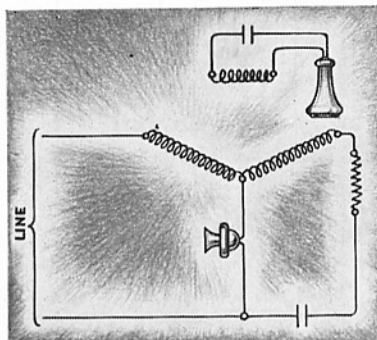

Kellogg Master-phones are wired for the TRIAD anti-side tone circuit, a Kellogg development that represents a great advance in gaining top transmission and reception under modern operating conditions.

The TRIAD circuit was developed because of the increasing use of the handset, under all kinds

of conditions and by all types of people, presented a problem not present with the other types of telephones. The illustrations show just what these problems are.

It is well known to every telephone man that with the ordinary booster circuit all sounds picked up by the transmitter are carried direct to the receiver and then to the ear of the person talking. That is, he hears not only his own voice but all extraneous nearby sounds.

This effect is shown graphically in the illustration at the left. If the extraneous sounds get to the point where they interfere with his hearing, he generally changes his voice to overcome them, and thus further destroys the reception. If he is naturally a loud talker he can get farther from the mouthpiece.

The experienced subscriber using a phone with the old booster circuit has acquired the habit of putting his hand over the mouthpiece

to shut out the extraneous sounds while listening. Some desk phones have even been made with push buttons to cut out the transmitter. The illustration below shows this effect. Of course, this is only a makeshift for it still permits these sounds to annoy him when again talking, and still has the effect of making him talk too loud. In other words, he now hears better but he still destroys or injures his own transmission.

All of these things are present to some degree when a handset is used with the ordinary circuit, but now, as shown in the next illustration, the subscriber can't get farther away from the mouthpiece. If he raises his voice above the extraneous sounds, he not only suffers himself but he makes life miserable for the party he is talking to. With the modern types of handset transmitters this is magnified.

The subscriber, as shown in the next illustration, now has no recourse to his old stunt of putting his hand over the mouthpiece. And anyway, one of the chief advantages of the handset is that it is supposed to set one hand free. So, about all he can hope to do now is to clamp the receiver tighter to his ear (and probably cut down his hearing) and then cup his free hand around the mouthpiece.

While perhaps these problems have been exaggerated to illustrate the point, the fact remains that due to the type of construction and due to the development of finer transmitters in handsets, these problems are very real and must be met. It isn't very hard to rig up some so-called anti-side tone circuit, but it is difficult to do it without the sacrifice of transmission and without making the tone "lifeless" and the enunciation mushy. . . . The TRIAD circuit is the result of years of study and development —



it didn't just happen, although the sketch in the left hand column might make it appear simple. It is simple, now that it is perfected, but it does permit clear, sparkling transmission with little or no loss and it does handle those annoying outside noises.

As a further refinement the No. 106-A TRIAD circuit induction coil used in common battery Master-phones has been provided with an extra balancing tap for short loop subscribers. The coil is regularly



connected for maximum transmission on average battery supply values, but by moving the wire from terminal 6 to 7 on the coil, additional resistance may be cut in to balance the circuit for the subscriber on a minimum loop with a high battery supply.

Thus, the anti-side tone feature adjusts itself to long or short loops and provides the same clear cut, side tone-free transmission on short as well as long loops.

Ringing and Dialing Circuit Used in Kellogg X Type Masterphones

All Kellogg X type TRIAD circuit Masterphones are supplied with ringing condenser windings independent of the talking circuit. Thus all Masterphones are suited to either single party metallic, multi-party bridged, or divided ringing without alteration.

In harmonic codes the capacity of the ringer condenser is matched with the individual ringer characteristics, thus providing maximum ringing efficiency at all frequencies. As the higher frequency ringers have a better response with low capacity condensers, the use of $\frac{1}{2}$ microfarad windings in these cases, reduces the over-all capacity of party lines and makes for high efficiency dialing.

A further refinement in the ringer circuit is the ringer cut off in the switch. Thus, a subscriber on a party line removes both ringer and condenser before dialing, further increasing dialing efficiency.

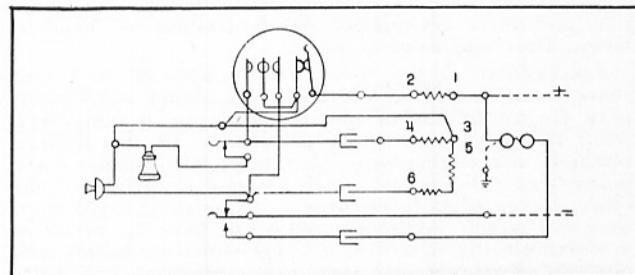

Schematic Diagram of "X" Type Masterphone Circuit

Telephone Section

Kellogg Masterphones

KELLOGG has the distinction of being the oldest manufacturer of handset telephones in the United States. It pioneered in the design, development and marketing of the first American-made instruments of this type, back in 1906. Since that time all engineering work on handsets has been a modification of the original Kellogg Grabaphone. This broad knowledge of handset design and long-experienced engineering development furnishes unequalled leadership upon which is based the Kellogg Masterphone line.

Kellogg Masterphones are available in a complete range of wall and desk type instruments for main station and extension use; and for magneto, common battery manual and dial service. All are small and compact with simple lines that harmonize with any surroundings, whether in home, office, factory, school, hospital, or wherever modern telephones are required.

Smart styling and easy handling are almost as important to today's telephone as good transmission, reception and ringing. Kellogg engineers were the first to recognize this trend and set the pace for beautiful, practical telephones.

THE famous Kellogg NON-POSITIONAL transmitter comes as standard equipment with all Masterphones. The balanced 4-conductor TRIAD (anti-side tone) circuit is also a standard Masterphone feature. These important factors, plus Kellogg's highly efficient, yet small sized ringers, condensers, induction coils, self-contained capsule type transmitter and receiver units and practical designing . . . all go to make these Masterphones the finest quality instruments obtainable.

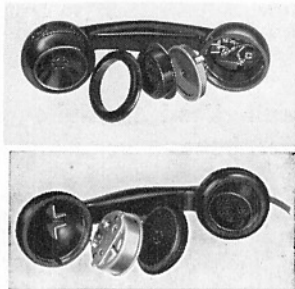

Masterphone Handpiece
with Capsule Type Transmitter and Receiver

The Masterphone handpiece was the first with streamlined, smooth-flowing lines, unmarred by projecting earcaps and mouthpiece rings; the first with no exposed metal parts, all Bakelite exterior and the first handpiece comfortable to hold and designed to fit the face. It was the first with self-contained capsule type transmitter and receiver units.

The first to employ bronze contact clips on these units in place of screw terminals. The first to provide a strong handpiece by eliminating the hole through the center and molding into the solid Bakelite handle two heavy bronze reinforcing conductor bars. It was the first handpiece to overcome costly maintenance.

Today this handpiece is standard with all Kellogg Masterphones whether wall type or desk type, which consequently provides uniform transmission and reception and most economical standardization of handles, transmitters and receiver units.

Forerunners to the trend which appeared in recent years toward smaller, less bulky telephone instruments were the availability of new materials on a commercial scale and new engineering principles. In the Kellogg research and engineering laboratory, new smaller components were developed which equaled or surpassed the older, larger parts in efficiency. These new, small parts were not merely miniature copies but were the result of new engineering advances, new principles of design, new material developments, new requirements . . . parts which were better, regardless of size.

Because of these highly efficient small parts, Kellogg was able to produce telephone housings so trim and compact that they experienced immediate acceptance. The unusual popularity of the Kellogg Combination Masterphones is the result of combining in the base of the telephone all of the parts formerly mounted in a separate desk set box. Most telephone installations today, for desk use, are of this Combination type.

In the design of parts and equipment, Kellogg engineers have earned a reputation for careful planning to provide for economical interchangeability. This is illustrated by the fact that with the exception of the condenser, all of the parts in the Masterphone Combination desk sets, the new small Masterphone wall sets and the Bakelite desk set boxes are interchangeable. Thus, a Combination Masterphone may be purchased less ringer, coil and condenser for use with a Bakelite desk set box. Parts from the box, with the exception of the condenser, may be transferred to the telephone to make a complete Combination Masterphone when such is required. This interchangeability feature alone makes it worthwhile to standardize on the Kellogg Masterphone line.



Side Mounting Masterphone
for Manual Service



Side Mounting Masterphone
for Dial Service

Kellogg Masterphones

Masterphone handsets are designed for easy handling. It is easy to hand the telephone across a desk. Only one hand is necessary, for the Masterphone is easy to grip and light to carry. Its compactness, low center of gravity and lightweight, yet rugged construction protect your investment.

The Kellogg wall Masterphones have some uses beyond the regular desk type handsets. They are equally efficient for the office or home. They may be placed over a table or desk leaving the surface free for writing. They may be placed high on the wall, out of reach of children, still permitting their use by a person of any height. Used with them is the Masterphone handpiece, same as used with all other Masterphones.

The deep, form-fitting cradle used with these wall sets is so designed that it is impossible to knock off the handpiece under normal conditions. Yet, it can be removed easily for use. Also for a convenient, firm and comfortable grip.

Kellogg Masterphones May Easily Be Picked Up with One Hand

it is in the normal position

Because parts have been standardized and are interchangeable Masterphones may be purchased with just as much equipment as needed at the time. To meet new conditions new parts may be ordered, or transferred from other telephones or desk set boxes.

Kellogg's long experience in the use of Bakelite for telephones is brought out in efficient yet beautiful design which has not only cut down the possibilities of breakage but makes all parts easily accessible. A screw driver is the only tool necessary to remove any part used in the Masterphone line of telephones. Even this is not necessary to remove the transmitter and receiver.

Handsets must stand abuse. Subscribers will drop them or knock them over in spite of all precautions. That's why Kellogg Masterphones are built so ruggedly and reinforced at every point of strain. A glance inside the base tells the story. Here, molded of solid Bakelite, are extra supports, inserts and extra wall thickness. These reinforcements are provided at every possible point of strain. For less maintenance use Masterphones.

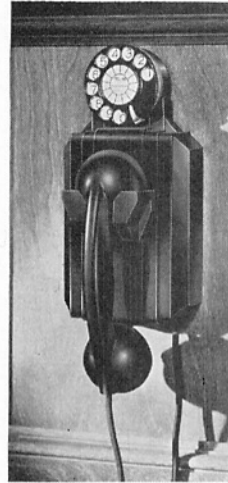
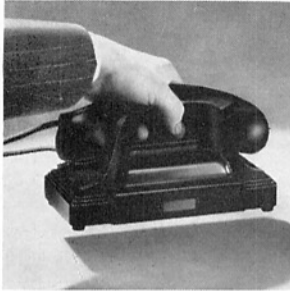

9917 Type Wall Masterphone



925 Type Desk Masterphone

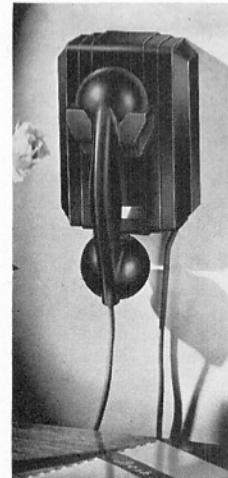

9900 Type Wall Masterphone



900 Type Desk Masterphone



Side Mounting Masterphone with Switching Key



The Masterphone Handpiece Cannot Be Knocked Down

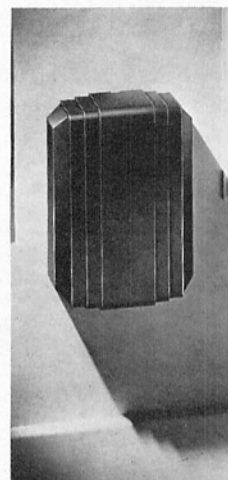

700 Type Desk Set Box



700 Type Masterphone with 700 Desk Set Box

Telephone Section

Kellogg Masterphone^{REGISTERED}s, Common Battery

925 Dial Type, Combination Sets

The 925 type Masterphone is available for dial service or for manual service. If furnished for manual service it may easily be converted to dial service by the addition of a dial. The base housing is made of black, satin-smooth Bakelite and with it is used the F-27-C Bakelite handset, equipped with the Kellogg patented NON-POSITIONAL transmitter. It is wired with the TRIAD anti-side tone circuit.

The base is 9½ inches long and 6 inches wide. With the handset in position, the set is 5½ inches high.

Ordering Information

Dial Is Furnished Only When Specified

No. 925-BAX, Common Battery

Complete, self-contained unit for use on single party lines or for code ringing service. Wired for TRIAD circuit. The ringer is provided with a biasing spring to prevent tapping of bells from stray impulses.

No. B-925-BAX, Common Battery, Divided Ringing

Same as 925-BAX but with three-conductor base cord and three-point connector block for divided ringing.

No. 925-HAX, Common Battery

Complete, self-contained unit, wired for TRIAD circuit, designed for harmonic ringing. No. 925-HAX-1 operates on a frequency of 33½ cycles; No. 925-HAX-2, 50 cycles; No. 925-HAX-3, 66⅔ cycles and No. 925-HAX-4, 16⅔ cycles. No. 925-HAX is also available for operation on a frequency of 25 cycles.

No. B-925-HAX, Common Battery, Divided Ringing

Same as No. 925-HAX but with three-conductor base cord and three-point connector block for divided ringing.

No. 925-HBX, Common Battery

Complete, self-contained unit, wired for TRIAD circuit and designed for harmonic ringing. No. 925-HBX-1 operates on a frequency of 30 cycles; No. 925-HBX-2, 42 cycles; No. 925-HBX-3, 54 cycles and No. 925-HBX-4, 66 cycles.

No. B-925-HBX, Common Battery, Divided Ringing

Same as No. 925-HBX, but with three-conductor base cord and three-point connector block for divided ringing.

No. 925-HCX, Common Battery

Complete, self-contained unit, wired for TRIAD circuit and designed for harmonic ringing. No. 925-HCX-1



operates on a frequency of 20 cycles and No. 925-HCX-2 on a frequency of 60 cycles.

No. B-925-HCX, Common Battery, Divided Ringing

Same as No. 925-HCX, but with three-conductor base cord and three-point connector block for divided ringing.

No. 925-LRX, Common Battery

Complete, self-contained unit, less ringer. For use as an extension set. Space is provided for adding a ringer later. Wired for TRIAD circuit.

No. B-925-LRX, Common Battery, Divided Ringing

Same as No. 925-LRX but with three-point connector block for divided ringing.

No. 925, Common Battery or Local Battery

For use with common battery TRIAD circuit desk set boxes, Nos. 610 or 700. For local battery service use four-conductor anti-sidetone desk set boxes Nos. 4328, 4362, etc.

No. 925-A, Common Battery or Local Battery

For common battery service, use with three-conductor booster circuit desk set boxes Nos. 602 or 429.

Also convertible to No. 925 for use with TRIAD circuit anti-sidetone desk set boxes by removing auxiliary designation clips and attaching a No. F-685-D four-conductor cord in place of the three-conductor base cord.

No. 930-C-LR, Local Battery

Masterphone with TRIAD local battery induction coil, four-conductor cord and condenser in receiver circuit. Makes an excellent extension talking set. Used with 2500 series of desk set boxes containing generators and ringers.

No. 930-LR, Local Battery

Same as No. 930-C-LR but less condenser.

Major Parts Which Apply to Specific Types

Other piece parts for 925 type are shown in the table on opposite page.

Telephone Code No.	Ringer	Induction Coil	†Condenser	Interior Conn. Rack	Base Cord	Connecting Block	Plunger Switch Plate Assembly	Shipping Weight Each, Lbs.
925-BAX	Biased	116-G	106-A	203	58729	F-665-D	24-A	62391 9
B-925-BAX	Biased	116-G	106-A	203	58729	F-640-D	24-B	62391 9
925-HAX	Harmonic	112-A	106-A	203 or 206	58729	F-665-D	24-A	62391 9
B-925-HAX	Harmonic	112-A	106-A	203 or 206	58729	F-640-D	24-B	62391 9
925-HBX	Harmonic	113-A	106-A	203 or 206	58729	F-665-D	24-A	62391 9
B-925-HBX	Harmonic	113-A	106-A	203 or 206	58729	F-640-D	24-B	62391 9
925-HCX	Harmonic	115-A	106-A	203 or 206	58729	F-665-D	24-A	62391 9
B-925-HCX	Harmonic	115-A	106-A	203 or 206	58729	F-640-D	24-B	62391 9
925-LRX	None	106-A	203	58729	F-665-D	24-A	62391 8	
B-925-LRX	None	106-A	203	58729	F-640-D	24-B	62391 8	
925	None	None	None	None	F-685-D	None	58737 7	
925-A	None	None	None	None	F-674-D	None	59469 7	
930-C-LR	None	109-A	199	60168	F-685-D	24-A	61212 8	
930-LR	None	109-A	None	60168	F-685-D	24-A	61212 8	

†No. 203 Condenser is equipped with a 1 MF ringer winding and should be used with biased or with 16⅔, 33⅓, 50, 20, 25, or 30 cycle harmonic ringers. No. 206 Condenser is equipped with a

½ MF ringer winding and should be used with 42, 54, 66 and 66⅔ cycle harmonic ringers.

Telephone Section

Kellogg Masterphones, Common Battery

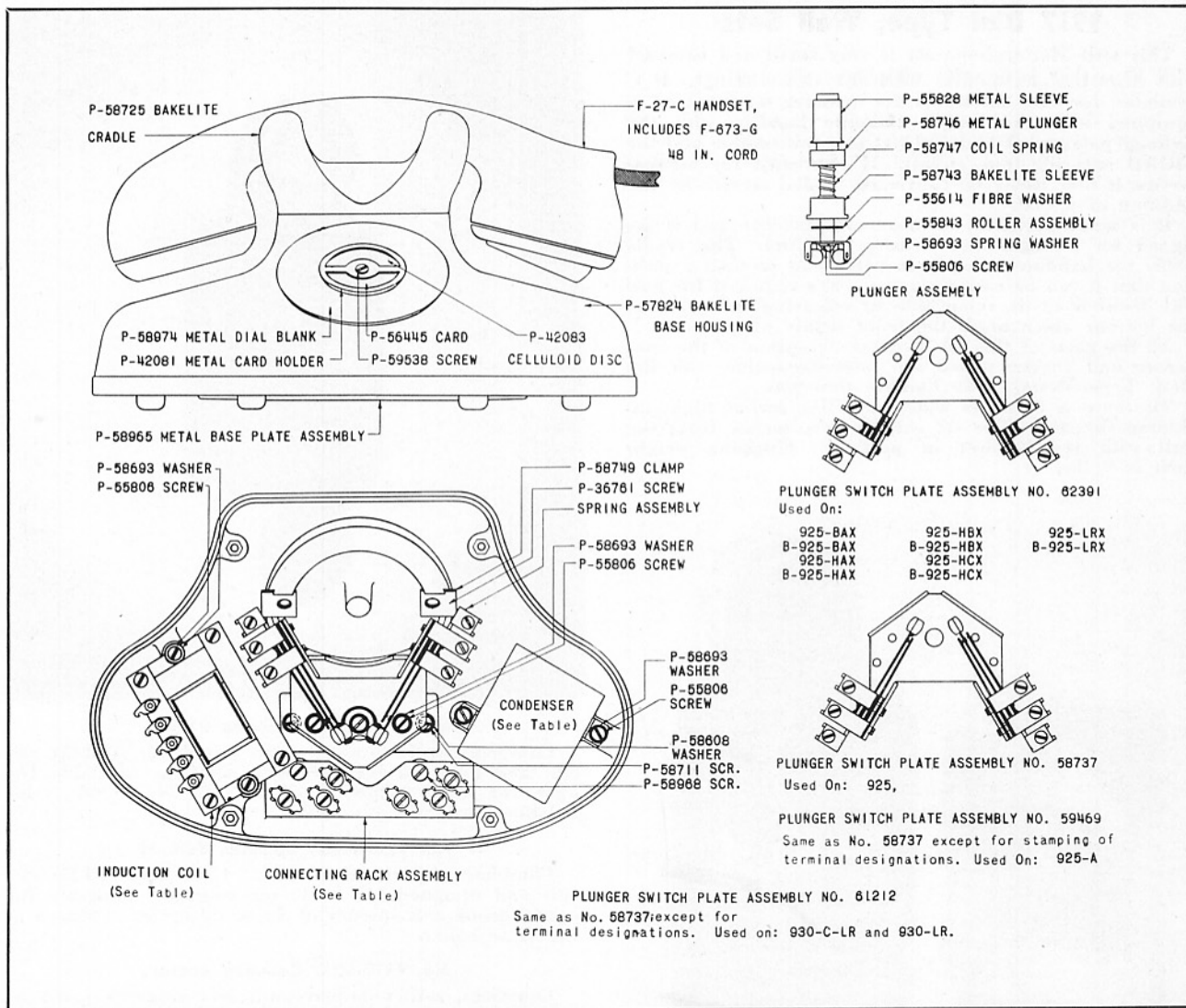

Parts Used in All 925 Type Masterphones

Part or Code No.	Description	Quantity Used	Part or Code No.	Description	Quantity Used
.....	Dial — Furnished and mounted only when specified. (Please specify type of dial required.)	1			
F-27-C	Handset, used with all Masterphones.	1			
	Detailed specifications on page 23.				
58724	Bakelite Base Housing	1			
58725	Bakelite Cradle	1			
58965	Metal Base Plate Assembly, Rubber Feet	1			
58964	Base Plate Retaining Screws	4			
	Dial Blank Number Plate				
	Parts are furnished when dial is not specified and mounted.				
58974	Metal Dial Blank	1			
42081	Metal Card Holder	1			
56445	Round Card	1			
42083	Round Celluloid Disc	1			
59538	Screw	1			
55352	Washer	1			
	Dial Mounting Parts				
58749	Clamp	2			
36761	Screw	2			
				Plunger Switch Parts	
			58746	Chromed Metal Plunger	1
			55828	Chromed Metal Sleeve	1
			58747	Coil Spring	1
			58743	Bakelite Sleeve	1
			55843	Roller Assembly	1
			55806	Roller Assembly Screw	1
			55614	Fiber Washer	1
			58693	Spring Washer	1
				Miscellaneous Mounting Screws and Washers	
			58711	Screw to Fasten Cradle to Housing	2
			58608	Washer	2
			55806	Screw to Mount Plunger Switch Assembly	2
			58693	Washer	2
			55806	Screw to Mount Condenser	2
			58693	Washer	2
			55806	Screw to Mount Induction Coil	2
			58693	Washer	2
			58968	Screw to Mount Connecting Rack	2

Telephone Section

Kellogg Masterphone[®]s, Common Battery

9917 Dial Type, Wall Sets

This wall Masterphone set is very small and compact with lines that harmonize with any surroundings. It is available for dial service or for manual service, and is equipped with the F-27-C Bakelite handset with the Kellogg patented NON-POSITIONAL transmitter and the TRIAD anti-side tone circuit. If furnished for manual service it may easily be converted to dial service by the addition of a dial.

It is made of black, satin-smooth Bakelite and is designed for strength and wearing qualities. The cradle holds the handpiece firmly in place and in such a position that it can be easily grasped when required for use. The front is easily removable by releasing the catch at the bottom which holds the front firmly in place.

All the parts of this set with the exception of the condenser and trigger switch are interchangeable with the Desk Type Masterphone Combination Sets.

The base is 5 inches wide and 10¼ inches high, including the dial. The set extends 4¾ inches from the wall with the handset in position. Shipping weight each is 9 lbs.

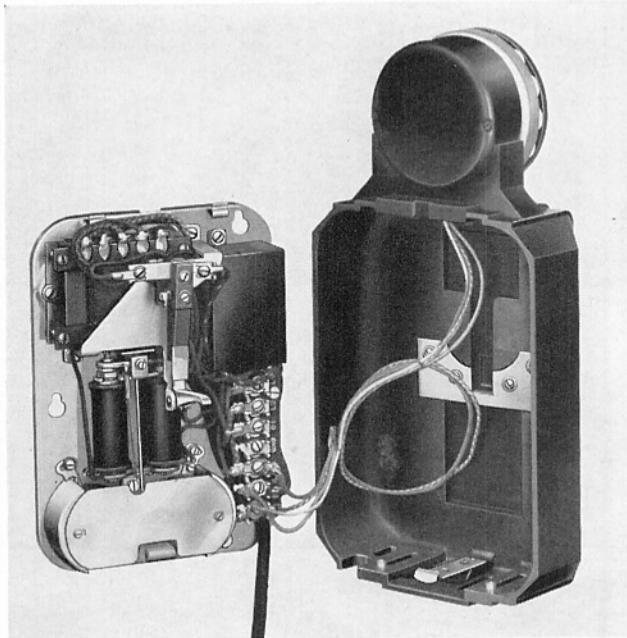

Interior View, Complete Assembly

Ordering Information

Dial Is Furnished Only When Specified

All 9917 "X" type Masterphones are suitable for either metallic or divided ringing as they are provided with a condenser of suitable capacity, permanently wired into the ringer circuit.

No. 9917-BAX, Common Battery

Complete, self-contained unit for use on single party lines or for code ringing service. Wired for TRIAD circuit. The ringer is provided with a biasing spring to prevent tapping of bells from stray impulses.

No. 9917-HAX, Common Battery

Complete, self-contained unit, wired for TRIAD circuit and designed for harmonic ringing. Available for operation on a frequency of 33⅓, 50, 66⅔, or 16⅔ cycles as shown in the table at right. (25 cycles also available.)

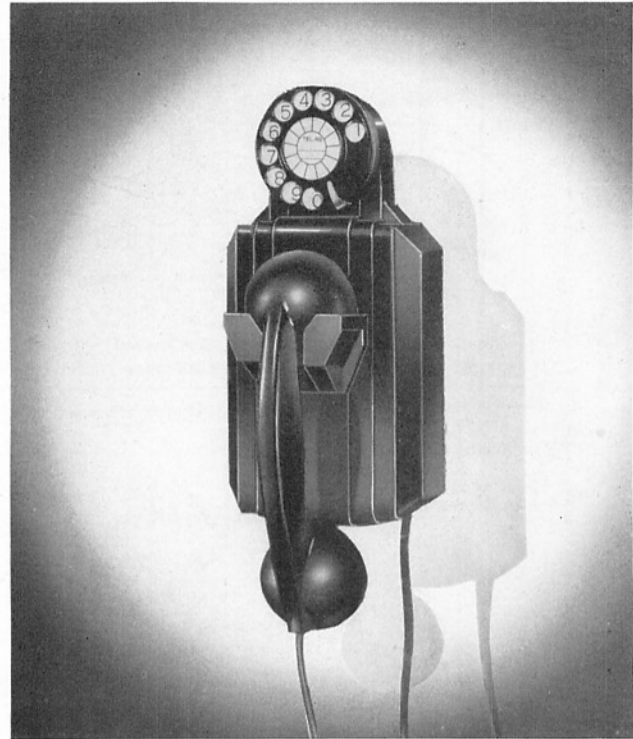

No. 9917-HBX, Common Battery

Complete, self-contained unit, wired for TRIAD circuit and designed for harmonic ringing. Available for operation on a frequency of 30, 42, 54, or 66 cycles as shown in the table below.

No. 9917-HCX, Common Battery

Complete, self-contained unit, wired for TRIAD circuit and designed for harmonic ringing. Available for operation on a frequency of 20 or 60 cycles as shown in the table below.

No. 9917-LRX, Common Battery

Complete, self-contained unit, less ringer for use as an extension set. Space is provided for adding a ringer later. Wired for TRIAD circuit.

Major Parts Which Apply to Specific Types

Other piece parts for type 9917 are shown in table on opposite page.

Telephone Code No.	Description	Ringer	Frequency in Cycles	Con- denser	Shpg. Wt. Each, Lbs.
9917-BAX	Biased	116-G	204	9
9917-HAX-1	Harmonic	112-A-1	33⅓	204	9
9917-HAX-2	Harmonic	112-A-2	50	204	9
9917-HAX-3	Harmonic	112-A-3	66⅔	207	9
9917-HAX-4	Harmonic	112-A-4	16⅔	204	9
9917-HBX-1	Harmonic	113-A-1	30	204	9
9917-HBX-2	Harmonic	113-A-2	42	207	9
9917-HBX-3	Harmonic	113-A-3	54	207	9
9917-HBX-4	Harmonic	113-A-4	66	207	9
9917-HCX-1	Harmonic	115-A-1	20	204	9
9917-HCX-2	Harmonic	115-A-2	60	207	9
9917-LRX	204	9

Kellogg Masterphones, Common Battery

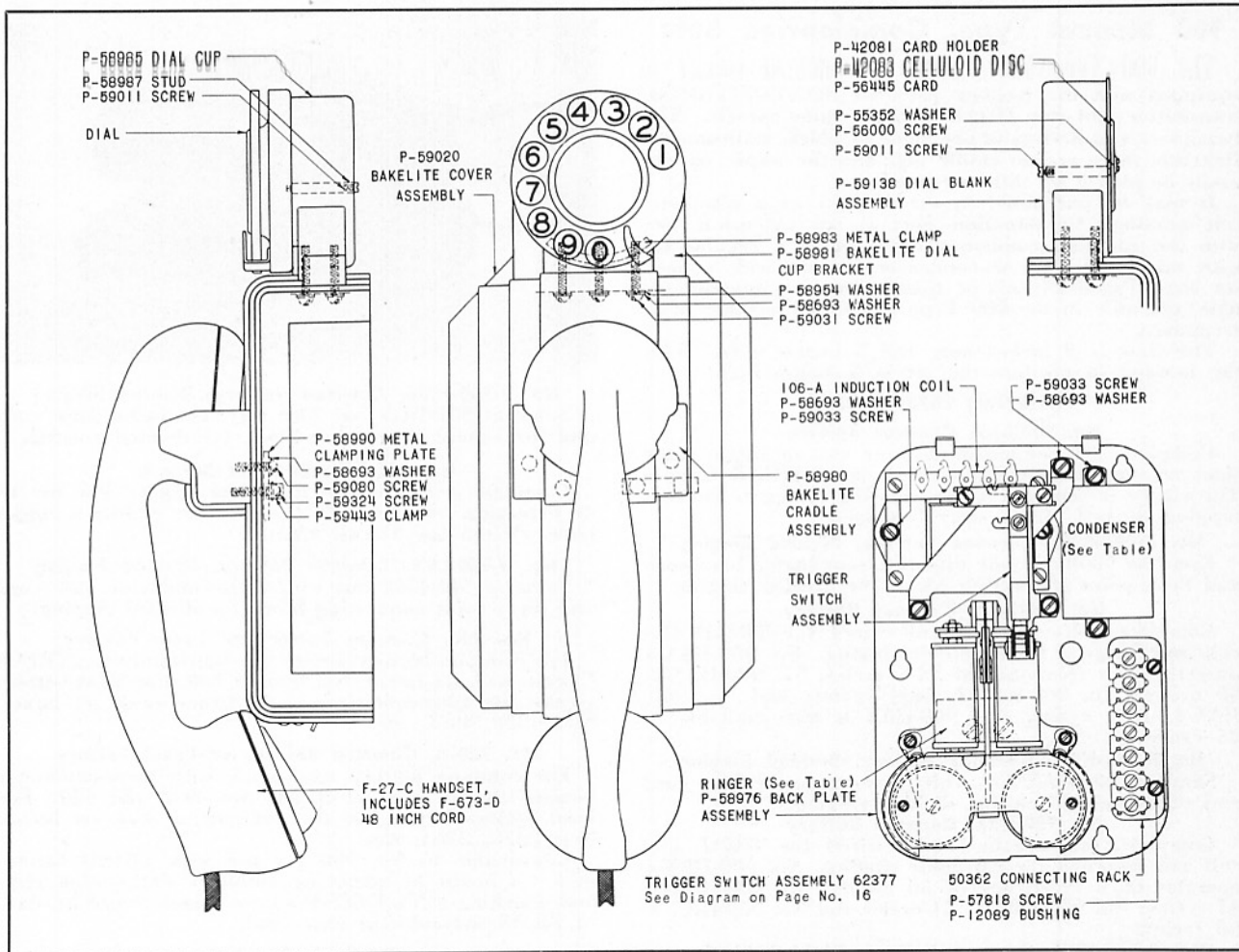

Parts Used in All 9917 Type Wall Masterphones

Piece Part or Code No.	Description	Quantity Used	Piece Part or Code No.	Description	Quantity Used
.....	Dial is furnished and mounted only when specified. (Please specify type desired.)				
F-27-C	Handset used with all Masterphones.....	1			
	Detailed specifications on Page 23				
58976	Base Plate	1			
50362	Connecting Rack	1			
106-A	Induction Coil	1			
62377	Trigger Switch Assembly.....	1			
59020	Bakelite Cover	1			
58980	Bakelite Cradle Assembly	1			
	Cradle Mounting Parts				
58990	Metal Clamping Plate.....	1			
59080	Cradle Mounting Screw.....	2			
59324	Cradle Mounting Screw.....	2			
58693	Spring Washer	4			
59443	Clamp for Dial Wires.....	1			
	Dial Bracket and Number Plate				
58981	Bakelite Dial Cup Bracket.....	1			
58985	Dial Cup	1			
58983	Metal Clamp	1			
59031	Screw	3			
58954	Washer	3			
58693	Spring Washer	3			
				Dial Blank Number Plate	
				Parts not furnished when dial is specified and mounted.	
			59138	Metal Dial Blank.....	1
			56445	Round Card	1
			42083	Round Celluloid Disc	1
			42081	Metal Card Holder.....	1
			56000	Screw	1
			55352	Spring Washer	1
				Dial Mounting Parts	
			59011	Screw	2
			58987	Dial Mounting Stud.....	2
				Miscellaneous Mounting Screws and Washers	
			59033	Screw for Trigger Switch.....	3
			58693	Washer	3
			59033	Screw for Mounting Condenser.....	2
			58693	Washer	2
			59033	Screw for Induction Coil.....	2
			58693	Washer	2
			57818	Screw for Connecting Rack.....	2
			12089	Connecting Rack Bushing.....	2

Telephone Section

Kellogg Masterphon^{es}, Common Battery

900 Manual Type, Combination Sets

The 900 Type Masterphone for manual service is equipped with the Kellogg patented NON-POSITIONAL transmitter and the TRIAD anti-side tone circuit. The handpiece and deskstand are made of black, satin-smooth Bakelite, there are no cradle lugs and the whole set can easily be picked up with one hand.

It may be purchased in three ways: as a complete, self-contained Combination Set; as an extension set; with the coil and condenser only; or as a regular set with no ringer, coil or condenser for use with a desk set box. Practically all of these parts are interchangeable, not only in the 900 Type but with the other Masterphones.

The base is 9 inches long and 5 inches wide. With the handset in position the set is 5 inches high.

Ordering Information

No. 900-BAX, Common Battery

Complete, self-contained unit for use on single party lines or for code ringing service, wired TRIAD Circuit. The ringer is provided with a biasing spring to prevent tapping of bells from stray impulses.

No. B-900-BAX, Common Battery, Divided Ringing

Same as 900-BAX but with three-conductor base cord and three-point connecting block for divided ringing.

No. 900-HAX, Common Battery

Complete, self-contained unit wired for TRIAD Circuit and designed for harmonic ringing. No. 900-HAX-1 operates on a frequency of 33 $\frac{1}{3}$ cycles, No. 900-HAX-2, 50 cycles; No. 900-HAX-3, 66 $\frac{2}{3}$ cycles; and No. 900-HAX-4, 16 $\frac{2}{3}$ cycles. No. 900-HAX is also available in 25 cycles.

No. B-900-HAX, Common Battery, Divided Ringing

Same as 900-HAX but with three-conductor base cord and connecting block for divided ringing.

No. 900-HBX, Common Battery

Complete, self-contained unit, wired for TRIAD Circuit and designed for harmonic ringing. No. 900-HBX-1 operates on a frequency of 30 cycles; No. 900-HBX-2, 42 cycles; No. 900-HBX-3, 54 cycles and No. 900-HBX-4, 66 cycles.

No. B-900-HBX, Common Battery, Divided Ringing

Same as 900-HBX but with three-conductor base cord and three-point connecting block for divided ringing.

No. 900-HCX, Common Battery

Complete, self-contained unit wired for TRIAD Circuit and designed for harmonic ringing. No. 900-HCX-1 operates on a frequency of 20 cycles and No. 900-HCX-2 on a frequency of 60 cycles.

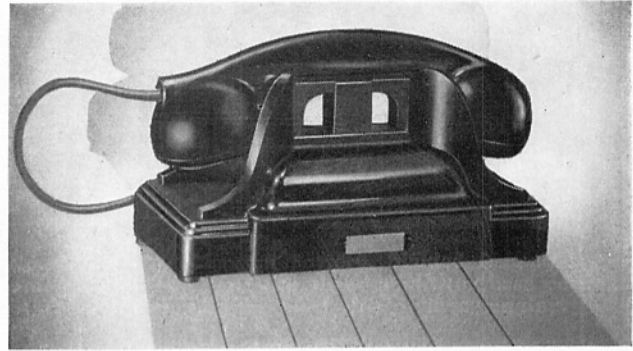

No. B-900-HCX, Common Battery, Divided Ringing

Same as 900-HCX but with three-conductor base cord and three-point connecting block for divided ringing.

No. 900-LRX, Common Battery

Complete self-contained unit, less ringer. For use as an extension set. Space is provided for adding a ringer later. Wired for TRIAD Circuit.

No. B-900-LRX, Common Battery, Divided Ringing

Same as 900-LRX but with three-conductor base cord and three-point connecting block for divided ringing.

No. 900, Common Battery or Local Battery

For common battery service use four-conductor TRIAD Circuit desk set boxes, No. 610 or 700. For local battery service use four-conductor anti-sidetone desk set boxes, Nos. 4328, 4362, etc.

No. 900-A, Common Battery or Local Battery

For common battery service use with three-conductor booster circuit desk set boxes, Nos. 602 and 429. For local battery service use three-conductor desk set boxes, Nos. 2328, 2361, etc.

Convertible to No. 900 for use with TRIAD Circuit desk set boxes by removing auxiliary designation clips and attaching a No. F-685-D four-conductor cord in place of the three-conductor base cord.

No. 950-C-LR, Local Battery

Masterphone with TRIAD local battery induction coil, four-conductor cord, and condenser in receiver circuit. Makes an excellent extension set. May be used with No. 2500 series of desk set boxes containing generators and ringers.

No. 950-LR, Local Battery

Same as No. 950-C-LR but less condenser.

Major Parts Which Apply to Specific Types

Other piece parts for 900 type are shown on the opposite page.

Telephone Code No.	Ringer	Induction Coil	†Condenser	Interior Conn. Rack	Base Cord	Connecting Block	Plunger Switch Plate Assembly	Shipping Weight Each, Lbs.
900-BAX	Biased	116-C	106-A	209	60168	F-665-D	24-A	62378 8
B-900-BAX	Biased	116-C	106-A	209	60168	F-640-D	24-B	62378 8
900-HAX	Harmonic	112-A	106-A	209 or 210	60168	F-665-D	24-A	62378 8
B-900-HAX	Harmonic	112-A	106-A	209 or 210	60168	F-640-D	24-B	62378 8
900-HBX	Harmonic	113-A	106-A	209 or 210	60168	F-665-D	24-A	62378 8
B-900-HBX	Harmonic	113-A	106-A	209 or 210	60168	F-640-D	24-B	62378 8
900-HCX	Harmonic	115-A	106-A	209 or 210	60168	F-665-D	24-A	62378 8
B-900-HCX	Harmonic	115-A	106-A	209 or 210	60168	F-640-D	24-B	62378 8
900-LRX	None	106-A	209	60168	F-665-D	24-A	62378 7	
B-900-LRX	None	106-A	209	60168	F-640-D	24-B	62378 7	
900	None	None	None	None	F-685-D	None	59105 7	
900-A	None	None	None	None	F-674-D	None	58700 7	
950-C-LR	None	109-A	193	60168	F-685-D	24-A (2)	61211 7	
950-LR	None	109-A	None	60168	F-685-D	24-A (2)	61211 7	

† No. 209 Condenser should be used with biased and with 16%, 33 $\frac{1}{3}$, 50, 20, 25 and 30 cycle harmonic ringers.
No. 210 Condenser is used with 42, 54, 66 and 66 $\frac{2}{3}$ cycle harmonic ringers.

Kellogg Masterphones, Common Battery

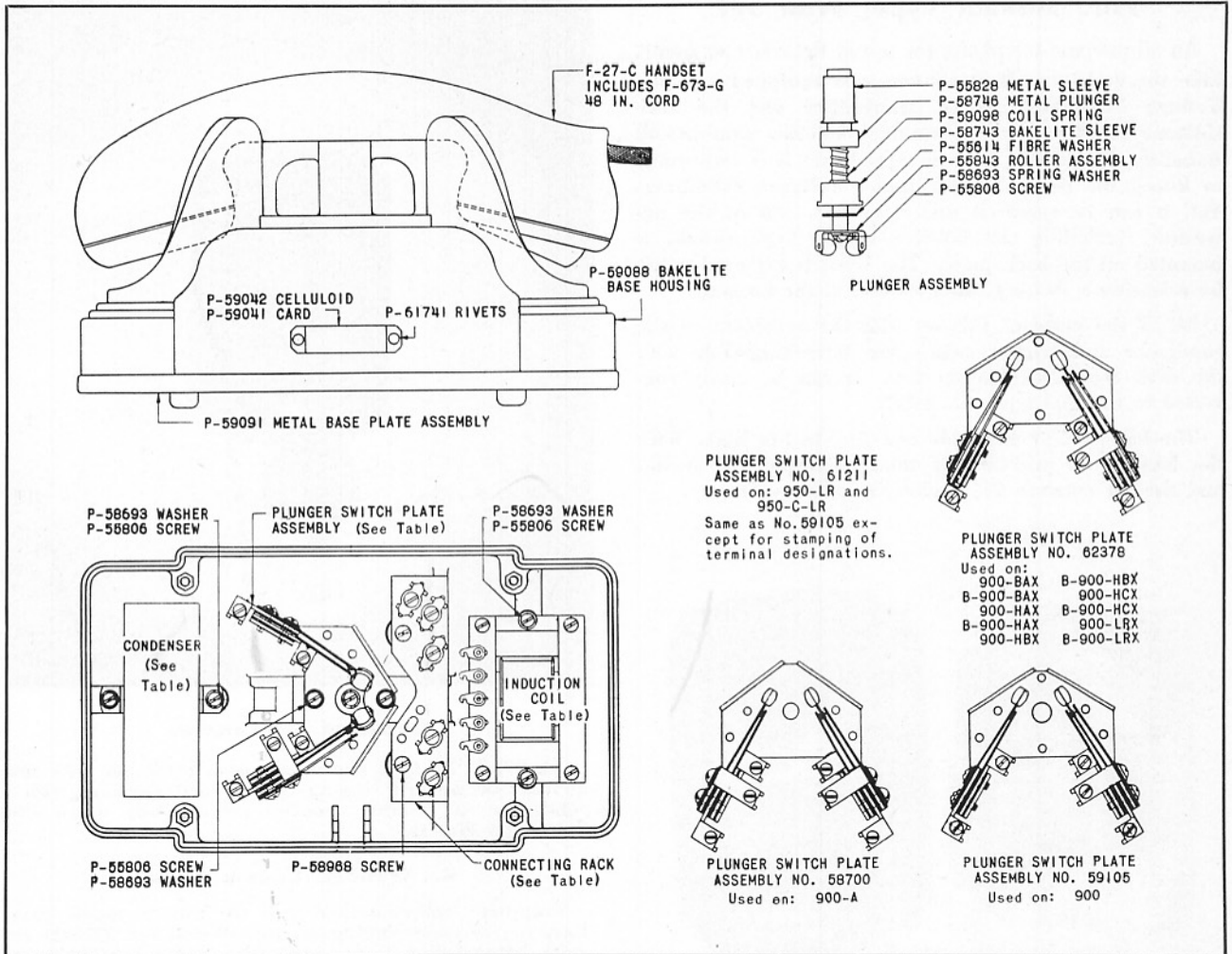

Parts Used in All 900 Type Masterphones

Piece Part or Code No.	Description	Quantity Used	Piece Part or Code No.	Description	Quantity Used
F-27-C	Handset used with all Masterphones.....	1	59098	Coil Spring	1
	Detailed specifications on Page 23		58743	Bakelite Sleeve	1
59088	Bakelite Base Housing.....	1	55843	Roller Assembly	1
59091	Metal Base Plate Assembly with Rubber Feet	1	55806	Roller Assembly Screw.....	1
58964	Base Plate Retaining Screw.....	4	55614	Fibre Washer	1
			58693	Spring Washer	1
Number Plate Parts			Miscellaneous Mounting Screws and Washers		
59042	Celluloid	1	55806	Screw to Mount Plunger Switch Assembly..	2
59041	Card	1	58693	Washer	2
61741	Rivet	2	55806	Screw to Mount Condenser.....	2
			58693	Washer	2
Plunger Switch Parts			55806	Screw to Mount Induction Coil.....	2
59097	Chromed Metal Plunger	1	58693	Washer	2
55828	Chromed Metal Sleeve.....	1	58968	Screw to Mount Connecting Rack.....	2

Telephone Section

Kellogg Masterphones, Common Battery

9900 Manual Type, Wall Set

An all purpose telephone for use in the office or home. Like the desk type Masterphone it is equipped with the Kellogg NON-POSITIONAL transmitter and the anti-sidetone TRIAD circuit. It is made of black, satin-smooth Bakelite. The cradle is so designed that it is impossible to knock off the handpiece under ordinary conditions. Yet, it can be removed easily for use. All of the apparatus, including the positive trigger type switch, is mounted on the back plate. The front is removed easily by releasing a locking catch located at the bottom.

All of the parts of this set with the exception of the condenser and trigger switch are interchangeable with the desk type Combination sets. It can be easily converted to the dial type, No. 9917.

The base is 5 inches wide and 7¼ inches high. With the handset in position the total height is 9¾ inches and the set extends 4¾ inches from the wall.

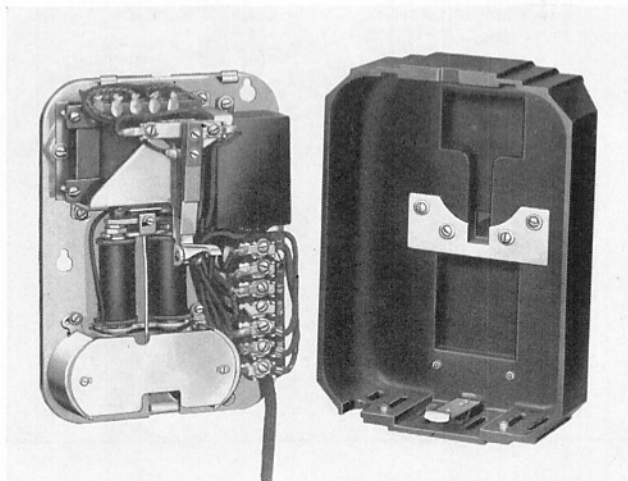

Interior View, Complete Assembly

Major Parts Which Apply to Specific Types

Other piece parts for type 9900 Masterphones are shown in table on opposite page.

Telephone Code No.		Ringer	Cycles	Condenser	Shipping Wt. Ea. Lbs.
9900-BAX	Biased	116-G	204	8
9900-HAX-1	Harmonic	112-A-1	33⅓	204	8
9900-HAX-2	Harmonic	112-A-2	50	204	8
9900-HAX-3	Harmonic	112-A-3	66⅔	207	8
9900-HAX-4	Harmonic	112-A-4	16⅔	204	8
9900-HBX-1	Harmonic	113-A-1	30	204	8
9900-HBX-2	Harmonic	113-A-2	42	207	8
9900-HBX-3	Harmonic	113-A-3	54	207	8
9900-HBX-4	Harmonic	113-A-4	66	207	8
9900-HCX-1	Harmonic	115-A-1	20	204	8
9900-HCX-2	Harmonic	115-A-2	60	207	8
9900-LRX	204	8

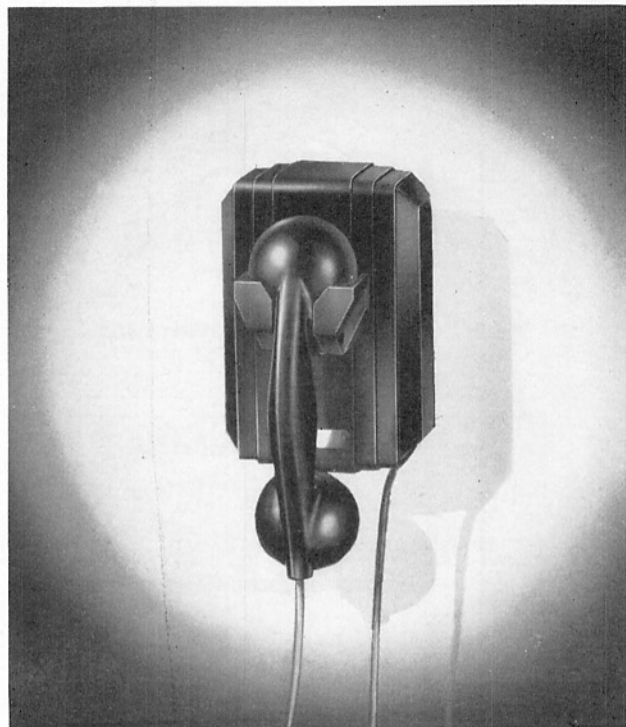

Ordering Information

All 9900 "X" type Masterphones are suitable for either metallic or divided ringing as they are provided with a condenser of suitable capacity permanently wired into the ringer circuit.

No. 9900-BAX, Common Battery

Complete, self-contained unit for use on single party lines or for code ringing service. Wired for TRIAD circuit. The ringer is provided with a biasing spring to prevent tapping of bells from stray impulses.

No. 9900-HAX

Complete, self-contained unit, wired for TRIAD circuit and designed for harmonic ringing. Available for operation on a frequency of 33⅓, 50, 66⅔ or 16⅔ cycles as shown in the table in the left-hand column.

No. 9900-HBX, Common Battery

Complete, self-contained unit, wired for TRIAD circuit and designed for harmonic ringing. Available for operation on a frequency of 30, 42, 54 or 60 cycles as shown in the table in the left-hand column.

No. 9900-HCX, Common Battery

Complete, self-contained unit, wired for TRIAD circuit and designed for harmonic ringing. Available for operation on a frequency of 20 or 60 cycles as shown in the table in the left-hand column.

No. 9900-LRX, Common Battery

Complete, self-contained unit, less ringer for use as an extension set. Space is provided for adding a ringer later. Wired for TRIAD circuit.

Kellogg Masterphones, Common Battery

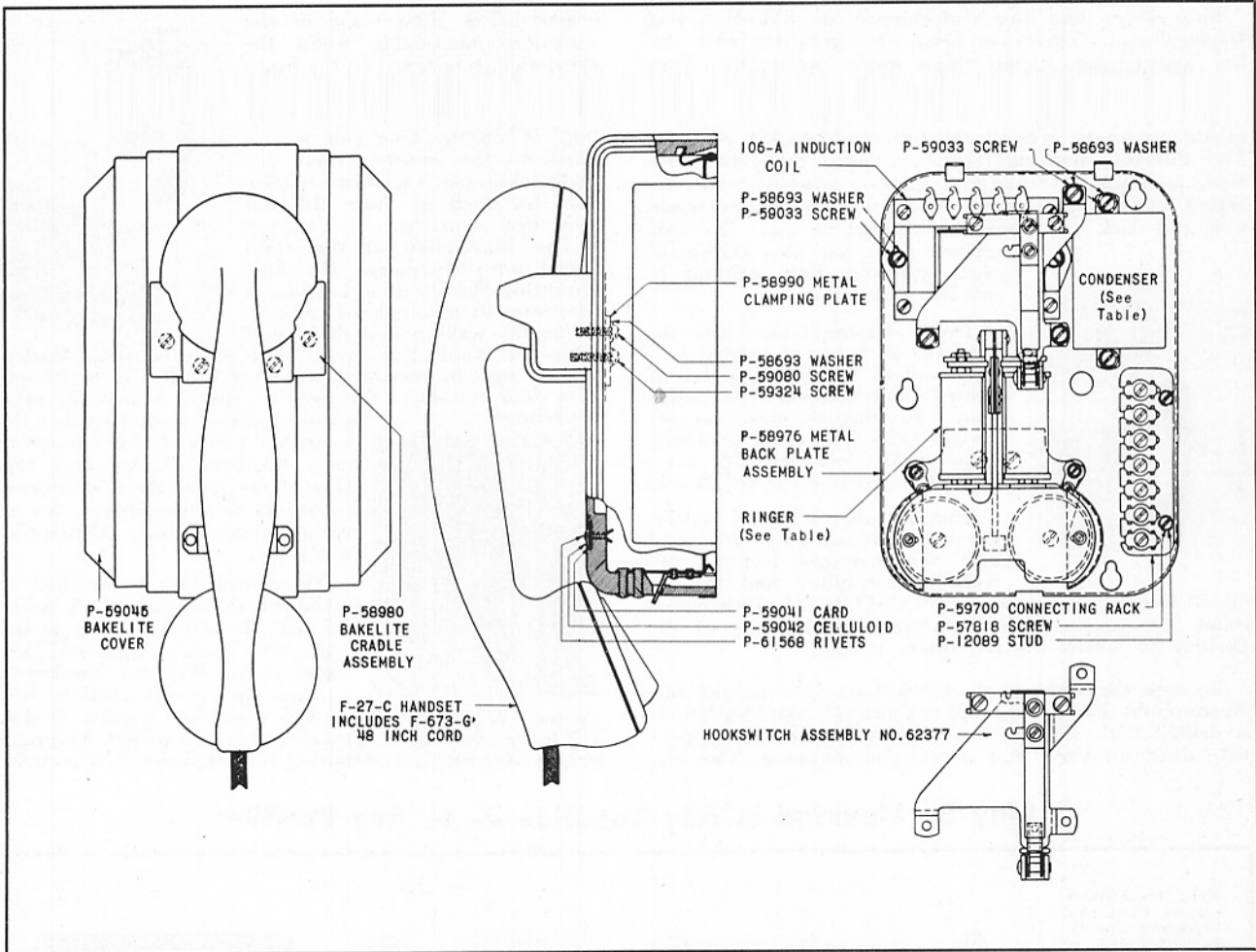

Parts Used in All 9900 Type Wall Masterphones

Piece Part or Code No.	Description	Quantity Used	Piece Part or Code No.	Description	Quantity Used
F-27-C	Handset used with all Masterphones	1			
	Detailed specifications on Page 23				
58980	Bakelite Cradle Assembly	1			
59045	Bakelite Cover	1			
58976	Back Plate	1			
106-A	Induction Coil	1			
62377	Trigger Switch Assembly	1			
59700	Connecting Rack	1			
	Cradle Mounting Parts				
58990	Metal Clamping Plate	1			
59080	Cradle Mounting Screw	2			
59324	Cradle Mounting Screw	2			
58693	Spring Washers	4			
				Number Plate Parts	
			59041	Card	1
			59042	Celluloid	1
			61568	Rivets	2
				Miscellaneous Mounting Screws and Parts	
			59033	Screw for Mounting Trigger Switch	3
			58693	Washer	3
			59033	Screw for Mounting Condenser	2
			58693	Washer	2
			59033	Screw for Mounting Induction Coil	2
			58693	Washer	2
			57818	Screw for Mounting Connecting Rack	2
			12089	Connecting Rack Bushing	2

Telephone Section

Kellogg Side-Mounting Masterphones

Subscribers like the convenience of Side-Mounting Masterphones. Their low price, low installing cost and low maintenance make them more profitable. They mount anywhere because the universal bracket has over fifty different positions to fit extended table and desk tops, moldings, overhanging shelves, paneled walls, recessed cabinets and other locations where conventional wall and desk sets would be difficult to use. The subscriber even has the choice of eight different dial positions to suit his preference.



These Masterphones may be used for all types of service . . . as complete talking sets, or, as talking and ringing sets when used with desk set boxes or extension bells. The small steel case is practically indestructible . . . an ideal telephone for rough use.

Like all other types of Masterphones these sets come equipped with the standard Kellogg all-Bakelite handpiece and the famous Kellogg patented NON-POSITIONAL transmitter

which assures the finest transmission regardless of the position in which the handpiece is held.

Because the right angle bracket used to mount this Masterphone has a long and a short side, and each side is drilled with similar mounting holes, there are over fifty different ways that it may be mounted. The dia-

grams below show some of the variations obtainable when the short side is fastened to the housing. When the long side is fastened to the housing there are eight additional variations obtainable for each of four different mounting positions.

The illustration at the right shows how convenient the Side Mounting Masterphone is to users who want their telephones mounted on the wall so that desks and tables are kept clear. Also, these Side-Mounting Masterphones may be mounted on either the left or right side of a desk or table. The installer simply selects the most convenient mounting position for the bracket so that the instrument extends far enough to clear the over-hanging desk top. One of the more than 50 bracket mounting arrangements is sure to make a neat, handy, efficient installation.

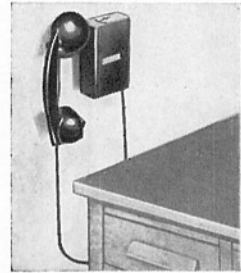

The metal case is finished in satin-smooth, durable black baked enamel. It measures 3 1/4 inches wide, 5 1/8 inches high and 1 3/4 inches deep. With the handset in position the overall width is 6 3/4 inches. The long side of the mounting bracket is 2 3/4 x 2 inches and the short side is 1 3/4 x 2 inches. Shipping weight of each Side-Mounting Masterphone is 8 pounds.

May Be Mounted in Any Location — In Any Position

Many installations require that the bracket be fastened to the Masterphone housing in this position. The four diagrams shown at the right illustrate how simply and easily the instrument can be raised, lowered or brought forward to suit specific conditions.

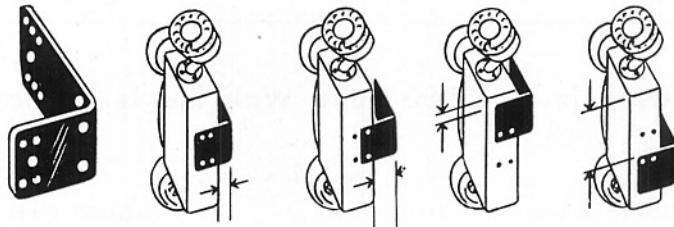

Other installations may require that the bracket be used in this position for proper mounting. Here again four illustrations show how the instrument can be raised, lowered or brought forward to extend above, below or beyond mounting surface.

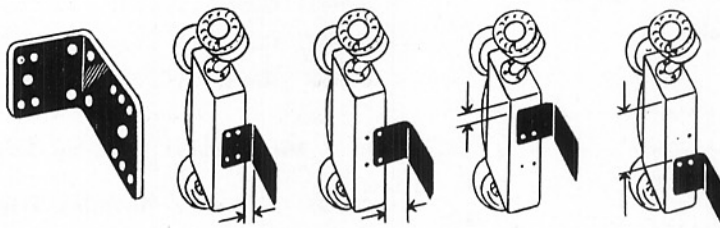

Here the bracket fastens to the side of the Masterphone housing for a front-mounting arrangement. These four diagrams show the same variations as above in the placing of the instrument, but with the bracket differently positioned to meet still other requirements.

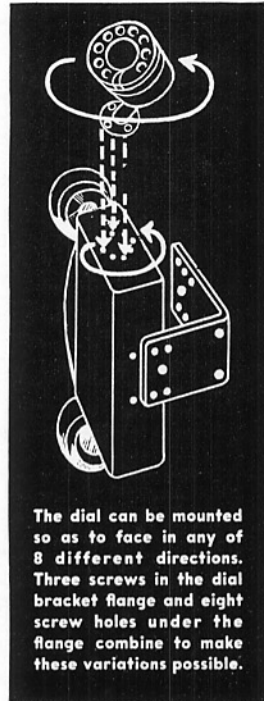
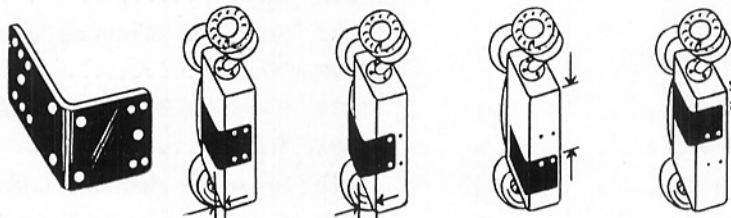

The dial can be mounted so as to face in any of 8 different directions. Three screws in the dial bracket flange and eight screw holes under the flange combine to make these variations possible.

Kellogg Side-Mounting Masterphones

For Dial Service

Dial Is Furnished Only When Specified
Piece Parts Are Shown on Page 20



No. 9740, Talking Set
Complete talking set, wired for TRIAD circuit. When bells are required order No. 705 Bakelite or No. 605 steel desk set box. Model 9740 may be used with any desk set box or extension bell containing a ringer and condenser.

No. 9741, Less Coil and Condenser
Furnished less induction coil and condenser. Adaptable to desk set boxes using either 2 winding (booster) or 3 winding (TRIAD) induction coils. When ordering new boxes we recommend No. 700 Bakelite or No. 610 steel TRIAD circuit desk set boxes.

For Manual Service

Piece Parts Are Shown on Page 20

No. 9720, Common Battery
Complete talking set, wired for TRIAD circuit. When bells are required order No. 705 Bakelite or No. 605 steel desk set box. Model 9720 may be used with any desk set box or extension bell containing a ringer and condenser.



No. 9735, Common Battery or Local Battery
Furnished less induction coil and condenser. Adaptable to desk set boxes using either 2 winding (booster) or 3 winding (TRIAD) induction coils. When ordering new boxes we recommend No. 700 Bakelite or No. 610 steel TRIAD circuit desk set boxes.

This set may also be used with magneto desk set boxes for local battery service.

No. 9830, Local Battery

Furnished with local battery TRIAD circuit induction

coil for magneto extension use. May be used as a complete telephone by connecting to the ringer and generator of an existing desk set box. When new boxes are ordered we recommend the No. 2500 line which is described in the Magneto Section of this catalog.

With Switching Key, Manual Service

No. 9736, Common or Local Battery

This Masterphone is the same as No. 9735 with the addition of a two-way switching key convenient to the subscriber's hand. This key combining the functions of a telephone and key box, can be used to switch one line to either of three extension telephones. It is often used in systems having two trunks and a separate inter-communication circuit. Because this Masterphone contains no induction coil or condenser it can be used with any common battery or magneto desk set box. Separate screw terminals and connecting racks are furnished for the telephone and the key unit, inside the housing.

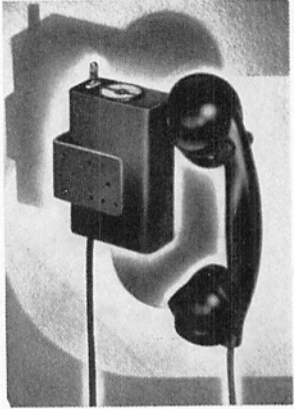

The diagram below shows the circuit arrangement for this type of phone.

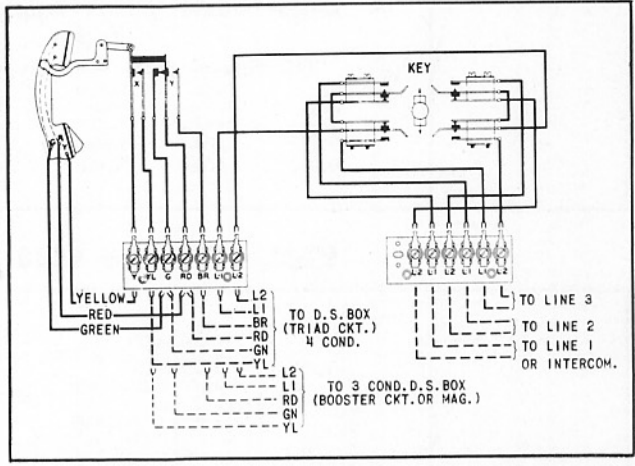

Front Mounting Wall Masterphone

An ideal, two-wire common battery unit without ringer, combining the patented Kellogg NON-POSITIONAL transmitter and the TRIAD anti-side tone circuit for best transmission. The small steel box is finished in a durable black baked enamel. The case is 4 inches wide, 5 1/2 inches high and 2 inches deep. With the handset in position the set extends 5 3/4 inches from the wall.



No. 9710, Common Battery

Complete talking set, wired for TRIAD circuit. When bells are required order No. 705 Bakelite or No. 605 steel desk set

box. Model 9710 may be used with any desk set box or extension bell containing a ringer and condenser.

No. 9837, Local Battery

Furnished with local battery TRIAD circuit induction coil for magneto extension use. May be used as a complete telephone by connecting to the ringer and generator of an existing desk set box. When new boxes are ordered we recommend the No. 2500 line which is described in the magneto section of this catalog.

Major Parts

Telephone Code No.	Induction Coil*	Condenser	Hookswitch Assembly	Hand-set
9710	103-A	186	158	F-27-C
9837	105-A	None	168	F-27-C

*Includes Connecting Rack

Telephone Section

Kellogg Side-Mounting Masterphones 9740 and 9741 — For Dial Service

DIAL CAN BE MOUNTED IN ANY OF 8 POSITIONS IN STEPS OF 45 DEGREES.

F-27-C HANDSET INCLUDES F-673-G 48 INCH CORD

P-59048 SCREW
164 HOOKSWITCH ASSEMBLY
P-58853 CONNECTING RACK
106-A INDUCTION COIL

DIAL

P-58987 STUD
P-59011 SCREW
P-59525 DIAL MOUNTING ARM AND COVER ASSEMBLY
P-59526 SCREW
CONDENSER (See Table)
P-59524 MOUNTING FRAME ASSEMBLY
P-58869 SCREW
P-58858 SCREW
96 NAME PLATE
P-58860 MOUNTING BRACKET
P-58869 SCREW
P-58857 METAL COVER ASSEMBLY
P-58858 SCREW
P-58840 SCREW

P-59138 DIAL BLANK ASSEMBLY
P-42081 CARD HOLDER
P-42083 CELLULOID PROTECTOR
P-56445 CARD
P-55352 WASHER
P-56000 SCREW

Parts Used in All 9740 and 9741 Side Mounting Masterphones

Part or Code No.	Description	Quantity Used
..... Dial furnished and mounted only when specified. (Please specify type of dial required.)		
	F-27-C Handset, Parts, page 23.	1
	58860 Mounting Bracket	1
	59525 Dial Mtg. Arm & Cap.	1
	58987 Dial Mounting Stud	2

Dial Blank Number Plate
Parts are not furnished when dial is specified and mounted. Part numbers on page 10.

Miscellaneous Mounting Screws

58840	Screw (Conn. Rack)	2
58858	Screw (Bracket & Cov.)	5
58869	Screw (9740 Only)	3
59048	Screw (Hookswitch)	3
59526	Screw (Dial Bracket)	3
59011	Screw (Dial Plate Mtg.)	2

Major Parts Which Apply to Specific Types

Tel. Code No.	Hook-switch Assem.	Induction Coil	Conn. Rack Assem.	Condenser
9740	164	106-A	58853	187
9741	164	None	58853	None

Other piece parts shown in table at right

9720, 9735 and 9830 — For Manual Service

P-56000 SCREW
P-42083 CELLULOID DISC
P-56445 CARD
P-42081 CARD HOLDER

CONDENSER (See Table)
P-58867 MTG. FRAME ASSEM.
P-58857 METAL COVER ASSEMBLY
P-58860 MOUNTING BRACKET
P-58869 SCREW
P-58840 SCREW
P-58858 SCREW

P-59048 SCREW
HOOKSWITCH (See Table)
F-27-C HANDSET INCLUDES F-673-G 48 INCH CORD
P-58853 CONNECTING RACK
INDUCTION COIL (See Table)

Major Parts Which Apply to Specific Types

Other piece parts are shown in table below

Tel. Code No.	Induction Coil	Condenser	Hook-switch Assem.
9720	106-A	187	164
9735	None	None	164
9830	109-A	None	169

Parts Used in All 9720, 9735 and 9830 Side Mounting Masterphones

Part or Code No.	Description	Quantity Used
F-27-C	Handset Used with All Masterphones, Specifications, page 23.	1
58860	Mounting Bracket	1
58853	Connecting Rack Assembly	1
42081	Metal Card Holder	1
42083	Round Celluloid Disc	1
56445	Round Card	1

Miscellaneous Mounting Screws

56000	Screw	1
58840	Screw	2
58858	Screw	5
58869	Screw (On 9720 & 9830 Only)	3
59048	Screw	3

Kellogg Masterphones, Common Battery

730 Dial Type, TRIAD Circuit

When used with the Kellogg 700, 610 or 439 desk set box the 730 Masterphone combines the use of the patented Kellogg NON-POSITIONAL transmitter and the TRIAD anti-side tone circuit to give the best in transmission.

The 730 Masterphone also makes an ideal extension set by wiring to the main station with quadruplex wire.

For manual or dial service. Manual type is easily converted to dial. Base and handset are Bakelite.

Dimensions: Base is 5¼ inches in diameter and with the handset in position the height is 4½ inches. Shipping weight each is 3 lbs.

725 Dial Type, Booster Circuit

Identical in construction to the 730 Masterphone except provided with a three-conductor desk set cord for the booster circuit. Used with 602 desk set box.

Parts Used in 730 and 725 Masterphones

Piece Part or Code No.	Description	Quantity Used
.....	Dial Furnished and Mounted Only When Specified (Please Specify Type of Dial Required)	1
F-27-C	Handset, Used with All Masterphones. Detailed Specifications on Page 23.....	1
41976	Base Housing	1
55899	Cradle	1
55843	Roller Bracket Assembly.....	1
55828	Bushing	1
55837	Spring	1
55846	Sub Base Assembly.....	1
35104	Base Plate Assembly.....	1
55829	Bushing	1
55855	Plunger Assembly	1

Miscellaneous Mounting Screws, Washers and Nuts

4477	Nut	1
48565	Nut	2
55806	Screw	3
19430	Screw	2
36761	Screw—Furnished Only When Dial Is Specified	3
55614	Washer	1
55850	Washer	1
58693	Spring Washer	3

Parts Used with No. 730 Only

57725	Spring and Bracket Assembly.....	1
F-685-D	Cord	1

Parts Used with No. 725 Only

F-674-D	Cord	1
---------	------------	---



No. 730 Masterphone and 700 Desk Set Box

Dial Blank Number Plate

Following parts are not furnished when dial is specified and mounted.

Piece Part No.	Description	Quantity Used
42081	Metal Card Holder.....	1
56445	Round Card	1
42083	Round Celluloid Disc.....	1
56437	Metal Dial Blank.....	1
56442	Clamp	1
55352	Washer	1
56000	Screw	1
56462	Screw	2

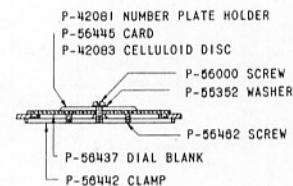
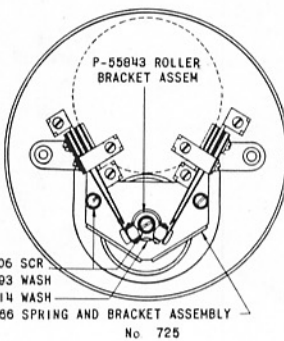
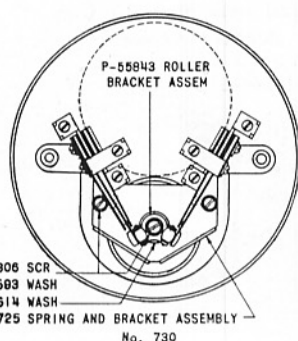
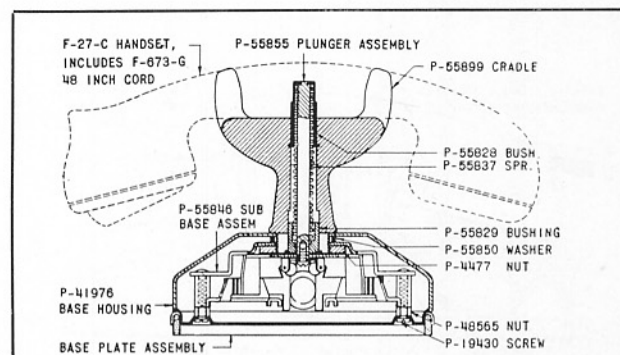

Telephone Section

Kellogg Masterphones, Common Battery

710 Manual Type, TRIAD Circuit



No. 710 Masterphone and 700 Type Desk Set Box

The Kellogg 710 Desk Masterphone combines the use of the patented NON-POSITIONAL transmitter and the TRIAD anti-side tone circuit to give the best in transmission. The black, satin-smooth Bakelite handset and base of this Masterphone are designed with simplicity, beauty and efficiency.

For common battery service use with four-conductor TRIAD circuit desk set boxes 700, 610 or 439.

For local battery service use with four-conductor desk set boxes 4328, 4362, etc.

The base is 9½ inches long and 4½ inches wide. The height with the handset in position is 4¾ inches. Shipping weight is 3 lbs.

No. 700-A Manual Type, Booster Circuit

The Kellogg 700-A Desk Masterphone can be used for common battery or local battery service with any standard bell box arranged for the conventional three-conductor booster circuit. It is identical to the 710 Masterphone in other respects.

For common battery service use desk set boxes 602 or 429. For local battery service use desk set boxes 2328, 2361, etc.

No. 700-A supersedes No. 700. Parts are interchangeable and 700-A is convertible to No. 710.

The base is 9½ inches long and 4½ inches wide. The height with the handset in position is 4¾ inches. Shipping weight is 3 lbs.

Parts Used in 700-A and 710 Masterphones

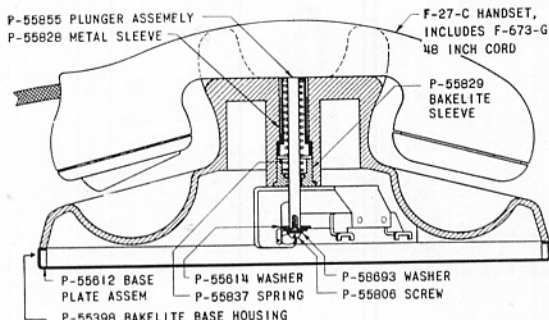

Piece Part or Code No.	Description	Quantity Used
F-27-C	Handset used with all Masterphones.	1
	Detailed specifications on Page 23	
55398	Bakelite Base Housing	1
55612	Felt Covered Metal Base Plate Assembly. . .	1
55855	Plunger Assembly	1
55843	Roller Bracket Assembly.	1
55828	Metal Sleeve	1
55837	Spring	1
55829	Bakelite Sleeve	1
Miscellaneous Mounting Screws and Washers		
55614	Washer	1
58693	Spring Washer	3
55806	Screw	3
Parts Used with No. 700-A Only		
58700	Spring and Bracket Assembly.	1
F-674-D	Cord	1
Parts Used with No. 710 Only		
57718	Spring and Bracket Assembly.	1
F-685-D	Cord	1

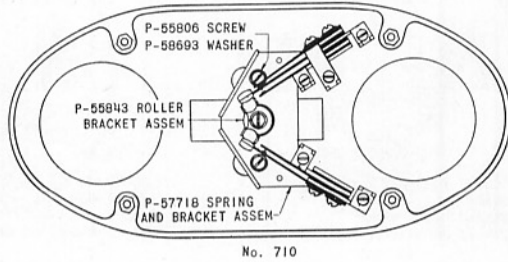
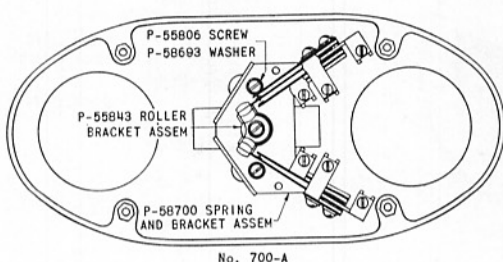

Bakelite Desk Set Boxes and Masterphone Handsets

Bakelite Desk Set Boxes

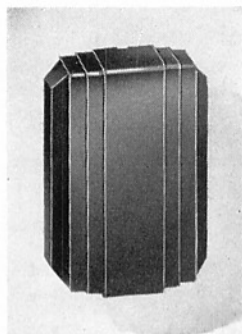

This smart, compact box is of black, durable Bakelite and contains the same small parts as used in Combination Masterphones. All of the apparatus is mounted on the base plate, compact but readily accessible. The cover can be completely removed by releasing a positive locking catch at the bottom. It measures only 7¼ inches high, 5¼ inches wide and 2¼ inches deep. Shipping weight each is 5 lbs.

Ordering Information and Major Parts

Type 700

Contains anti-sidetone coil, ringer and condenser for use with four conductor telephones Nos. 710, 900, 925, 305, 9735 and 9741.

Telephone Code No.		Ringer	Frequency in Cycles	Condenser
700-BA	Biased	116-G	204
700-HA-1	Harmonic	112-A-1	33½	189
700-HA-2	Harmonic	112-A-2	50	189
700-HA-3	Harmonic	112-A-3	66%	189
700-HA-4	Harmonic	112-A-4	16%	189
700-HB-1	Harmonic	113-A-1	30	189
700-HB-2	Harmonic	113-A-2	42	189
700-HB-3	Harmonic	113-A-3	54	189
700-HB-4	Harmonic	113-A-4	66	189
700-HC-1	Harmonic	115-A-1	20	189
700-HC-2	Harmonic	115-A-2	60	189
700-LR	None	189

Type 705

Contains ringer and condenser, for use with two conductor telephone or as extension bells.

Telephone Code No.		Ringer	Frequency in Cycles	Condenser
705-BA	Biased	116-G	191
705-HA-1	Harmonic	112-A-1	33½	191
705-HA-2	Harmonic	112-A-2	50	191
705-HA-3	Harmonic	112-A-3	66%	191
705-HA-4	Harmonic	112-A-4	16%	191
705-HB-1	Harmonic	113-A-1	30	191
705-HB-2	Harmonic	113-A-2	42	191
705-HB-3	Harmonic	113-A-3	54	191
705-HB-4	Harmonic	113-A-4	66	191
705-HC-1	Harmonic	115-A-1	20	191
705-HC-2	Harmonic	115-A-2	60	191

Piece Parts Used in All 700 and 705 Desk Set Boxes

Piece Part No.	Description	Quantity Used
59046	Bakelite Cover Assembly.....	1
58976	Back Plate Assembly.....	1
50362	Connecting Rack Assembly (700 only)....	1
53922	Connecting Rack Assembly (705 only)....	1
106-A	Induction Coil (Used in Type 700).....	1
Miscellaneous Mounting Screws and Washers		
58693	Washer for Connecting Rack.....	2
12089	Stud for Connecting Rack.....	2
59033	Screw for Mounting Condenser.....	2
57818	Screw for Mounting Connecting Rack....	2

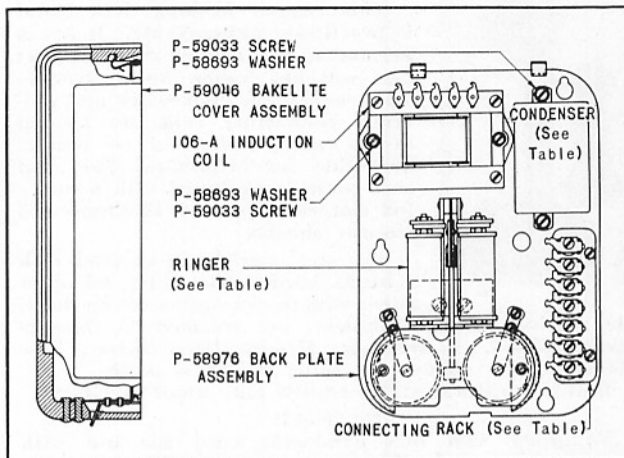

Masterphone Handset

This all-Bakelite handset is used as standard equipment with all Kellogg Masterphones. Other handsets for special applications are shown on Page No. 34.

The Kellogg patented NON-POSITIONAL transmitter is furnished in all these handsets and the receiver is of the bi-polar type using a cobalt magnet which has more magnetic saturation and longer life.

Both transmitter and receiver are of the capsule type, eliminating cord terminals and screws and as two brass bars molded into the Bakelite handle serve as conductors, to the transmitter and receiver, the cord connections are simple. Shipped with cords attached.

Length is 9 inches. Shipping weight each is 1½ lbs.

Major Parts

F-27-C Three Conductor Handset

Part No.	Description	Quantity Used	Part No.	Description	Quantity Used
55367	Handset Body Assembly	1	55369	Ring	1
55919	Receiver Assembly	1	58028	Ear Cap	1
57340	Transmitter Assembly	1	58015	Diaphragm	1
62505	Mouthpiece	1	F-673-G	Cord	1
			60788	Cord Attachment Screw	3



Telephone Section

DESK STANDS and DESK SET BOXES, Common Battery



This rugged Kellogg desk stand is practically unbreakable. It has a permanent transmitter adjustment that will not loosen up in service. The trouble-free hookswitch and universal connecting rack are located in the roomy base, and are readily accessible for inspection. The steel base plate is equipped with a heavy felt rim which protects furniture and absorbs shocks.

The steel upright is covered with a black, hard rubber tube. All other parts, with the exception of the Bakelite receiver and mouthpiece, are finished in durable black enamel. Dimensions: Height, 10 $\frac{3}{4}$ inches; base diameter, 5 $\frac{1}{4}$ inches. Shipping weight is 6 lbs.

Dial is furnished and mounted only when specified.

No. F-301

Equipped with three-conductor cord for use with booster circuit desk set boxes.

Desk Stands, Dial Type

No. 305

Same as F-301 except equipped with four-conductor cord for use with TRIAD anti-side tone desk set boxes, and with the new Bakelite transmitter front unit containing the Kellogg NON-POSITIONAL transmitter.

Major Parts

Piece No.	Part Description	Quantity Used	Piece No.	Part Description	Quantity Used
53586	Hookswitch Assembly	1	F-41-A	Receiver	1

Parts Used in No. F-301 Only

121-C	Transmitter	1	50360	Conn. Rack	1
43194	Spring Assem.	1	F-640-D	Cord	1

Parts Used in No. 305 Only

121-C	Transmitter	1	50825 &		
59130	Spring Assem.	1	59121	Conn. Rack	2
			F-685-D	Cord	1

Steel Desk Set Boxes



Heavy drawn steel box finished in durable black baked enamel. Special hinges allow cover to be completely removed. All parts are easily accessible and quickly removable with an ordinary screw driver. Connecting racks are clearly marked for convenience. Universal type terminals are used.

Dimensions: 3 $\frac{1}{2}$ inches deep; 9 inches high; 7 inches wide. Shipping weight each is 7 lbs.

Ordering Information and Major Parts

Type 602

For 3-conductor telephones, 700-A, 900-A, 925-A, 9735 and 9741.

Telephone Code No.		Ringer	Frequency, Cycles	Induction Coil	Con-denser
F-602-BA	Biased	79-A	99-A	177
F-602-HA-1	Harmonic	72-A-1	33 $\frac{1}{2}$	99-A	177
F-602-HA-2	Harmonic	72-A-2	54	99-A	177
F-602-HA-3	Harmonic	72-A-3	66 $\frac{2}{3}$	99-A	177
F-602-HA-4	Harmonic	72-A-4	16 $\frac{2}{3}$	99-A	177
F-602-HB-1	Harmonic	73-A-1	30	99-A	177
F-602-HB-2	Harmonic	73-A-2	42	99-A	177
F-602-HB-3	Harmonic	73-A-3	54	99-A	177
F-602-HB-4	Harmonic	73-A-4	66	99-A	177
F-602-HC-1	Harmonic	74-A-1	20	99-A	177
F-602-HC-2	Harmonic	74-A-2	60	99-A	177

Type 605

For use with 2-conductor telephones or as an extension bell. Space is provided for the addition of a No. 99-A coil.

Telephone Code No.		Ringer	Frequency, Cycles	Induction Coil	Con-denser
F-605-BA	Biased	79-A	none	177
F-605-HA-1	Harmonic	72-A-1	33 $\frac{1}{2}$	none	177
F-605-HA-2	Harmonic	72-A-2	50	none	177
F-605-HA-3	Harmonic	72-A-3	66 $\frac{2}{3}$	none	177
F-605-HA-4	Harmonic	72-A-4	16 $\frac{2}{3}$	none	177
F-605-HB-1	Harmonic	73-A-1	30	none	177
F-605-HB-2	Harmonic	73-A-2	42	none	177
F-605-HB-3	Harmonic	73-A-3	54	none	177

Telephone Code No.		Ringer	Frequency, Cycles	Induction Coil	Con-denser
F-605-HB-4	Harmonic	73-A-4	66	none	177
F-605-HC-1	Harmonic	74-A-1	20	none	177
F-605-HC-2	Harmonic	74-A-2	60	none	177
F-605-LR	none	none	177

Type 610

Contains TRIAD anti-side tone coil, for use with 4-cond. telephones 900, 925, 710, 305, 9735 and 9741.

Telephone Code No.		Ringer	Frequency, Cycles	Induction Coil	Con-denser
610-BA	Biased	79-A	103-A	185
610-HA-1	Harmonic	72-A-1	33 $\frac{1}{2}$	103-A	185
610-HA-2	Harmonic	72-A-2	50	103-A	185
610-HA-3	Harmonic	72-A-3	66 $\frac{2}{3}$	103-A	185
610-HA-4	Harmonic	72-A-4	16 $\frac{2}{3}$	103-A	185
610-HB-1	Harmonic	73-A-1	30	103-A	185
610-HB-2	Harmonic	73-A-2	42	103-A	185
610-HB-3	Harmonic	73-A-3	54	103-A	185
610-HB-4	Harmonic	73-A-4	66	103-A	185
610-HC-1	Harmonic	74-A-1	20	103-A	185
610-HC-2	Harmonic	74-A-2	60	103-A	185
610-LR	none	103-A	185

Piece Parts Used in All Type 602, 605 and 610

Piece Part No.	Description	Quantity Used	Piece Part No.	Description	Quantity Used
46940	Metal Cover	1	43588	Cord Fastener	1
48024	Back Plate Assembly	1	55261	Hinge	2
47057	Lock Bracket	1	56152	Cond. & Coil Mtg. Bracket	2

For Mounting Ringer

14762	Washer	2	3491	Screw	2
59477	Spring Washer	2			

For Mounting Lock and Hinge

47394	Screw	1	5376	Screw for Mtg. Brackets	4
772	Screw	2	27787	Ind. Coil Screw	2
24741	Screw	4			

For Mounting Conn. Rack in No. 605 Box

56655	Bushing	2	56657	Conn. Rack (Specify Stamping)	1
6218	Screw	2			

Strap and screw for mounting extra condenser for divided ringing in No. 602 Box are available.

KELLOGG TELEPHONES, Common Battery

Wall Type Telephones — Dial or Manual

The Kellogg 9817 Type Wall Masterphone with handset combines the use of the Kellogg patented NON-POSITIONAL transmitter and the balanced TRIAD anti-side tone circuit. The 817 type is equipped with the older regular transmitter and receiver. Both may be used for dial or manual service and when equipped for manual service may easily be converted to dial service. No. 817 may easily be converted to 9817 by the addition of the proper parts. Housing is metal, finished with black, baked enamel.

Dimensions: 6½ in. wide, 9 in. high and 3½ in. deep. Shipping weights: No. 9817, 11 lbs.; No. 817, 8 lbs.

Ordering Information

For divided ringing, order with a No. 176 Condenser, No. 47021 Holder and No. 32409 Screw.

No. 9817-BA and F-817-BA

For use on single party lines or for code ringing service. Wired for TRIAD circuit. The ringer is provided with a biasing spring to prevent tapping of bells from stray impulses.

No. 9817-HA and F-817-HA

Wired for TRIAD circuit, designed for harmonic ringing. Nos. 9817-HA-1 and F-817-HA-1 operate on a frequency of 33½ cycles; Nos. 9817-HA-2 and F-817-HA-2, 50 cycles; Nos. 9817-HA-3 and F-817-HA-3, 66⅔ cycles and Nos. 9817-HA-4 and F-817-HA-4, 16⅔ cycles.

No. 9817-HB and F-817-HB

Wired for TRIAD circuit, designed for harmonic ringing. Nos. 9817-HB-1 and F-817-HB-1 operate on a frequency of 30 cycles; Nos. 9817-HB-2 and F-817-HB-2, 42 cycles; Nos. 9817-HB-3 and F-817-HB-3, 54 cycles, and Nos. 9817-HB-4 and F-817-HB-4, 66 cycles.

No. 9817-HC and F-817-HC

Wired for TRIAD circuit, designed for harmonic ringing. Nos. 9817-HC-1 and F-817-HC-1 operate on a frequency of 20 cycles and Nos. 9817-HC-2 and F-817-HC-2 on a frequency of 60 cycles.

No. 9817-LR and F-817-LR

Complete telephone, less ringer, for use as an extension set. Space is provided for adding a ringer later. Wired for TRIAD circuit.

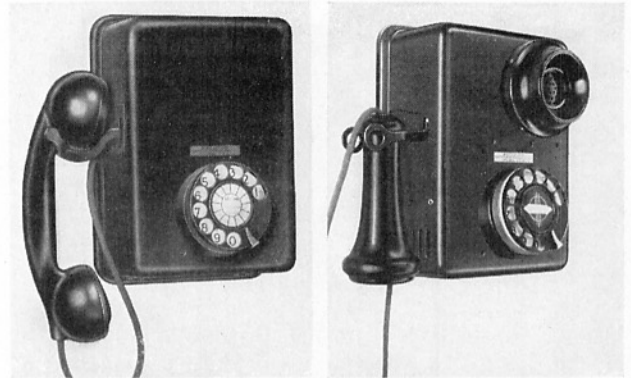

9817 Type

817 Type

Ringers Used with 9817 and 817 Masterphones

9817 Type	817 Type	Ringer No.	Frequency
9817-BA	F-817-BA	79-A
9817-HA-1	F-817-HA-1	72-A-1	33½ Cycles
9817-HA-2	F-817-HA-2	72-A-2	50 Cycles
9817-HA-3	F-817-HA-3	72-A-3	66⅔ Cycles
9817-HA-4	F-817-HA-4	72-A-4	16⅔ Cycles
9817-HB-1	F-817-HB-1	73-A-1	30 Cycles
9817-HB-2	F-817-HB-2	73-A-2	42 Cycles
9817-HB-3	F-817-HB-3	73-A-3	54 Cycles
9817-HB-4	F-817-HB-4	73-A-4	66 Cycles
9817-HC-1	F-817-HC-1	74-A-1	20 Cycles
9817-HC-2	F-817-HC-2	74-A-2	60 Cycles
9817-LR	F-817-LR	None

Parts Used in All No. 9817 Masterphones

Piece Parts for 817 type sets are the same as for the 9817 type except that 817 uses Cover Assembly No. 46963, Transmitter No. 121-C, Hookswitch No. 171, Transmitter Arm No. 39, and Receiver No. F-41-A.

Dial is furnished and mounted only when specified.

Piece Part or Code No.	Description	Quantity Used	Piece Part or Code No.	Description	Quantity Used
F-27-C	Handset used with all Masterphones. Detailed specifications on page 34.1	1	46956	Hinge	2
56368	Metal Cover Assembly	1	56152	Bracket	2
47390	Back Assembly	1	30483	Escutcheon Assembly	1
47057	Lock Bracket	1		Dial Blank Number Plate	
157	Hookswitch	1	56437	Dial Blank	1
103-A	Induction Coil	1	42081	Card Holder	1
43588	Cord Fastener	1	42082	Card	1
185	Condenser	1	42083	Celluloid Disc	1
50825	Conn. Rack Assembly (Dial)	1	56442	Clamp	1
47037	Cable Clamp	2	56462	Screw	2
			56000	Screw	1
				For Dial Connecting Rack	
51346	Washer	2	15098	Nut	2
44763	Screw	2		For Mounting Ringer	
			14762	Washer	2
			59477	Spring Washer	2
				For Cable Clamp	
3785	Screw	1	8992	Nut	1
				For Lock and Hinge	
47394	Screw	1	24741	Screw	4
7722	Screw	2		Miscellaneous Screws	
60024	For Mounting Hookswitch	2	5376	For Cond. Mtg. Bracket	4
27787	For Mounting Ind. Coil	2	36761	For Mtg. Dial	3

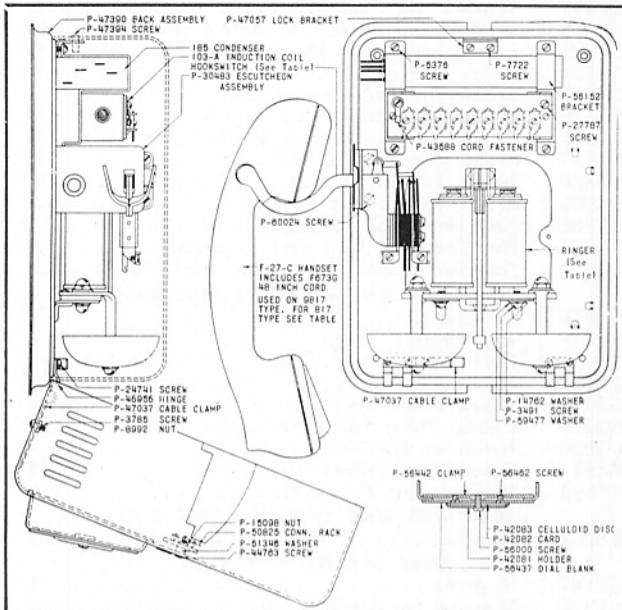

Telephone Section

WEATHERPROOF TELEPHONES, Common Battery

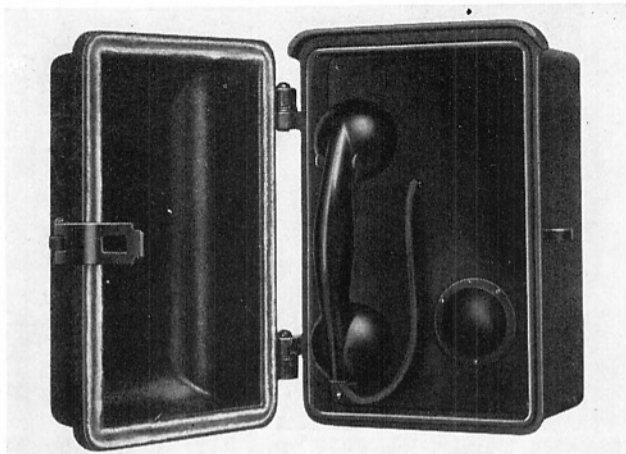

No. 4900 with Masterphone **NON-POSITIONAL** Handset

This Kellogg Outdoor Telephone is specially designed to meet requirements for an efficient, dependable common battery set at a low price. It is available with Kellogg Bakelite front, transmitter and receiver or with the Kellogg Masterphone **NON-POSITIONAL** handset. These sets are wired for either manual or dial type service. For dial service the dial blank may be removed and a dial installed.

These telephones are contained in a ventilated, cast-iron housing, the door of which is provided with a hasp that can be securely locked with an ordinary padlock. The top of the housing is tapped for standard 1/2-inch pipe fittings. The inner panel which mounts the switch-hook can be quickly removed by loosening four screws, giving easy access to all parts.

The inner rim of the housing is channeled and lined with an oil-impregnated felt gasket which fits over the ridge on the edge of the housing, thus sealing the case against moisture. All parts subject to damage by moisture are protected and treated with moistureproof finishes.

The coil mounts the connecting rack and both are fastened to a sliding Bakelite shelf. The Kellogg standard ringer used is of the biased armature type with 3-inch brass gongs and adjustable gong posts.

For special applications such as the operation of sirens, signal lights or loud-ringing bells from local power circuits, a variety of relay equipment is available. Ample space is provided in the ringer compartment for this auxiliary equipment.

Simplified wiring and rubber insulation is used throughout. There is no cabling. Four holes in the back of the housing are provided for mounting.

The overall dimensions are 12 1/4 in. high, 9 3/4 in. wide and 8 in. deep. Shipping weight is 40 lbs.

Ordering Information

For Manual or Dial Service — Common Battery

Dial furnished and mounted only when specified.

No. 4900, furnished with handset and **NON-POSITIONAL** transmitter and wired for **TRIAD** circuit.

No. 4901-A, furnished with Bakelite front **NON-POSITIONAL** transmitter and receiver and wired for booster circuit.

No. 4902, furnished with handset and **NON-POSITIONAL** transmitter and wired for **TRIAD** circuit. Equipped with resistor for use as emergency fire protection equipment. The resistor assures the telephone always being in working condition.

No. 4903, furnished with Bakelite front **NON-POSITIONAL** transmitter and receiver and wired for **TRIAD** circuit. Equipped with two condensers for divided ringing.

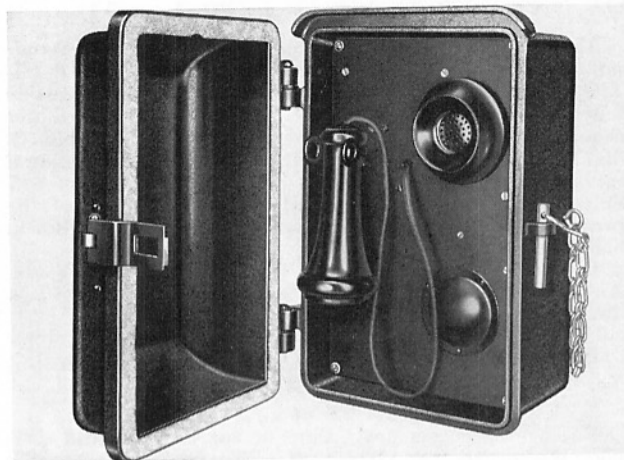

No. 4901 with Standard Receiver and Transmitter

Major Parts Which Apply to Specific Types

Telephone Code No.	Inner Door	Induction Coil	Con-denser	Hook-switch
4900	60037	103-GA	186	170
4901-A	57811	103	186	170
4902	62382	103-GA	186	170
4903	62486	103-GA	186 and 67	177

Parts Used in All Weatherproof Telephones

Piece Part or Code No.	Description	Quantity Used
57808	Screen	1
2922	Holder	1
57679	Felt Gasket	1
57813	Bracket for Mounting Ringer	2
108-GA	Ringer	1
5062	Cord Fastener	1
50636	Dial Blank	1
51346	Bushing for Connecting Rack	2
60013	Connecting Rack Assembly	1
Miscellaneous Washers, Screws and Nuts		
5445	Washer for Induction Coil	4
59477	Washer for Ringer	8
58693	Washer for Ind. Coil and Cond.	4
57021	Screw for Inner Door and Ringer Bkt.	6
5812	Screw for Hookswitch	4
57197	Screw for Induction Coil	2
15532	Screw for Ringer	2
57818	Screw for Connecting Rack	2
56957	Screw for Dial Blank	3
57820	Screw for Condenser	2
55806	Screw for Screen	2
44300	Nut for Hookswitch	4
36035	Nut for Ind. Coil and Condenser	4
57682	Nut for Conn. Rack and Dial Blank	5
Used with Nos. 4901 and 4903 Only		
60016	Transmitter	1
9227	Transmitter Front	1
F-41-GA	Receiver	1
29779	Mouthpiece	1
60018	Bracket for Transmitter	2
60019	Clamp Ring for Transmitter	1
60020	Insulator for Transmitter	1
5891	Screw for Transmitter	4
58694	Washer for Transmitter	4
Used with Nos. 4900 and 4902 Only		
F-27-EC	Handset	1
Used with No. 4902 Only		
62487	Resistor	1
61310	Washer for Resistor	5

Kellogg Masterphones, Magneto

Desk Masterphones, 925 Type

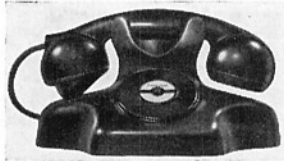

A complete, local battery talking set, convertible to common battery service, dial or manual, by changing the induction coil and adding ringer and condenser and dial. Used with 2500 series of desk set boxes (listed below) to make a complete telephone or with any available desk set box containing serviceable ringer and generator.

It is made of polished black Bakelite and with it is used the Masterphone F-27-C handset, equipped with the Kellogg patented, NON-POSITIONAL transmitter and high efficiency receiver. It is wired with the TRIAD anti-side tone local battery circuit. Furnished with a four-conductor cord for battery and line connections. The base is 9 inches long and 6 inches wide and with the handset in position the set is 5½ inches high.

For complete piece part information and diagrams, refer to pages 10 and 11.

No. 930-C-LR

Masterphone with TRIAD local battery induction coil No. 109-A, four-conductor cord, and condenser No. 199 in receiver circuit.

No. 930-LR

Same as 930-C-LR but less condenser.

Desk Masterphones, 900 Type

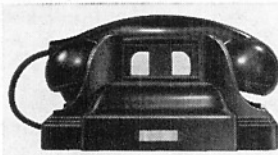

This is essentially the same telephone as the 930-LR listed above except that it is not convertible to dial service. Finished in polished black Bakelite, complete with TRIAD anti-side-tone induction coil and F-27-C handset

with NON-POSITIONAL transmitter unit. Used with 2500 series desk set boxes listed below or with any available boxes containing serviceable ringers and generators. Either this set or the 930-LR offers an excellent means of utilizing old boxes and at the same time, providing the latest in high efficiency transmission and reception. The 950-LR Masterphone is easily converted to common battery service by changing the induction coil and adding a ringer and condenser.

For complete piece part information and diagrams refer to pages 14 and 15.

No. 950-C-LR

Masterphone with TRIAD local battery induction coil, No. 109-A, four-conductor cord, and condenser No. 193.

No. 950-LR

Same as No. 950-C-LR but less condenser.

Magneto Desk Set Boxes

These boxes were specially designed for use with the 950-LR, 930-LR, 9830 and 9837 Masterphones. They contain no induction coils but are equipped with the Kellogg sensitive non-adjustable ringer and powerful three or five-bar generators. Three binding posts are provided for line and ground connections and four for cord or wire terminals from the Masterphone. Cabinets are built of solid oak, durably finished and measure 10¼ in. high, 8 in. wide and 6 in. deep.



Kellogg Side-Mounting Masterphones



No. 9830
Side Mounting

Subscribers like the convenience of Side Mounting Masterphones. Their low price, low installing cost and low maintenance make them more profitable. They mount anywhere because the universal bracket has over fifty different positions to fit extended table and desk tops, moldings, overhanging shelves, paneled walls, recessed cabinets and other locations where conventional wall and desk sets would be difficult to use.

Like all other types of Masterphones these sets come equipped with the standard F-27-C Kellogg all Bakelite handset and the famous Kellogg NON-POSITIONAL transmitter which

assures the finest transmission regardless of the position in which the handset is held.

With the 9830 side-mounting Masterphone you can convert your present desk set boxes into complete, modern wall telephones. Simply screw the bracket onto the side of the cabinet, run four wires from the terminal rack to the cord binding posts in the desk set box, remove the old induction coil and the job is complete.

Furnished with local battery TRIAD circuit induction coil. May be used as a complete telephone with 2500 series desk set boxes, containing ringer and generator or with available desk set boxes containing serviceable ringers and generators.

For complete piece part information and diagrams see pages 18, 19 and 20.

The baked black enameled steel case is 3¼ inches wide, 5½ inches high and 1¼ inches deep. With the handset in position the set is 6¾ inches wide. The long side of the mounting bracket is 2¾ x 2 inches and the short side is 1¾ x 2 inches.

Front-Mounting Extension Set



No. 9837
Front Mounting

An ideal extension set, furnished less ringer. With this set is furnished the Kellogg F-27-C Bakelite handset with the Kellogg patented NON-POSITIONAL transmitter. The TRIAD anti-side-tone local battery circuit is used for best transmission. The small drawn steel box, finished in durable black enamel, is 4 inches wide, 5½ inches high and 2 inches deep.

May be used as a complete telephone with 2500 series desk set boxes containing ringer and generator, or with available desk set boxes containing ringers and generators. For complete piece part information refer to page 19.

No. 2528, 1000 Ohm Ringer, 3 Bar Generator
For local lines with one or more phones and for lightly loaded farm lines.

No. 2561, 1600 Ohm Ringer, 5 Bar Generator
For long and heavily loaded lines.

No. 2562, 2500 Ohm Ringer, 5 Bar Generator
For long and heavily loaded lines.

Major Parts

Code No.	Generator	Ringer	Shipping Weight
F-2528	15	78-A	14 lbs.
F-2561	53	78-D	17 lbs.
F-2562	53	78-G	17 lbs.

Telephone Section

Kellogg Masterphones, Magneto

Desk Masterphones, 925 Type

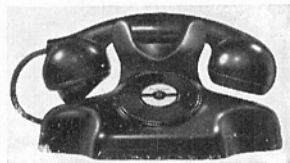

This set, No. 925-A, is similar in appearance to the 930-LR listed on page 27 but has no induction coil and is equipped with a three-conductor cord for attachment to standard three-conductor magneto desk set boxes containing two winding induction coils, generators and ringers. This is an excellent set for use with late type desk set boxes similar to the 2300 series listed below, but we recommend the purchase of the 930-LR Masterphone with its built-in anti-side tone induction coil for the most satisfactory all-around service. 925-A is convertible to dial service.

The base is 9½ inches long and 6 inches wide. With the handset in position the set is 5½ inches high.

For complete piece part information and diagram refer to pages 10 and 11.

Ordering Information — No. 925-A

For magneto service use three-conductor desk set boxes Nos. 2328, 2361, etc. Convertible to No. 925 for use with TRIAD anti-side tone circuit, common battery desk set boxes by removing auxiliary designation clips and attaching a No. F-685-D four-conductor cord in place of the three-conductor base cord.

Desk Masterphones, 700 Type



No. 700-A is a beautiful Bakelite set of the most pleasing design for use with desk set boxes containing two winding induction coil, ringer and generator, and equipped with a three-conductor cord. This set is not convertible to the complete

self-contained type but may be converted to the 710 four-conductor common battery model for use with anti-side tone desk set boxes, by changing the cord and removing auxiliary designations from the terminals.

Magneto Desk Set Boxes



We recommend these boxes for use with existing three-conductor handset telephones and desk stands. For those who purchase complete sets we recommend the 2500 series listed on the preceding page in connection with either the 950-LR or 930-LR, 9830 and 9837 sets equipped with anti-side tone induction coils.

The mounting space required is 10¼ in. by 8 in. The overall depth of the oak cabinet is 6 in. Shipping weight with 3-bar generator is 14 lbs. and with 5-bar, 17 lbs.

No. F-2328, 1000 Ohm Ringer, 3-Bar Generator

For local lines and for lightly loaded farm lines.

No. F-2361, 1600 Ohm Ringer, 5-Bar Generator

For long and heavily loaded lines.

Desk Masterphones, 900 Type

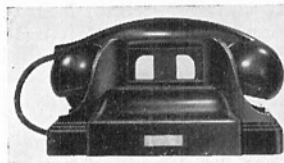

This set, No. 900-A, is essentially the same as the 925-A except that it is not convertible to dial service. It is equipped with transmitter, receiver, switch and three-conductor cord for use with 2328 series or other standard three-conductor desk set boxes. Unless available boxes contain late type induction coils we recommend the 950-LR set on page 27 for the most modern transmission and reception.

For complete piece part information and diagrams refer to pages 14 and 15.

Ordering Information — No. 900-A

For local battery service use three-conductor desk set boxes Nos. 2328, 2361, etc. Convertible to No. 900 for use with TRIAD anti-side tone circuit desk set boxes by removing auxiliary designation clips and attaching a No. F-685-D four-conductor cord in place of the three-conductor base cord.

Magneto Desk Stands



This rugged Kellogg desk stand is offered for those who prefer the pedestal type of desk telephone. It is equipped with transmitter, receiver, switch and three-conductor cord for use with the 2300 series of desk set boxes listed below. It is also convertible to dial operation by adding a dial and connecting it with a suitable three-conductor desk set box or it may be used for common battery manual operation by connecting it to the proper box.

Equipped with Bakelite transmitter front and mouthpiece unit, containing the Kellogg NON-POSITIONAL transmitter.

Ordering Information — No. 301

Equipped with three-conductor cord for use with booster circuit desk set boxes. For parts used see page 24.

No. F-2370, 1600 Ohm Ringer, 5-Bar Generator
Furnished with a ½ MF condenser in the receiver circuit. Will ring through heavily loaded lines even if receivers are down.

No. F-2362, 2500 Ohm Ringer, 5-Bar Generator
For long and heavily loaded lines.

No. F-2371, 2500 Ohm Ringer, 5-Bar Generator
Furnished with a ½ MF condenser in the receiver circuit. Will ring through heavily loaded lines even if receivers are down.

Major Parts

Code No.	Generator	Ringer	Induction Coil	Condenser
F-2328	15	78-A	108-A	none
F-2361	53	78-D	108-A	none
F-2370	53	78-D	108-A	28
F-2362	53	78-G	108-A	none
F-2371	33	78-G	108-A	28

Kellogg Telephones, Magneto

Wall Type Masterphones



This Kellogg Wall Type Masterphone consists of a standard Kellogg oak cabinet and a moulded Bakelite handset suspended on a special Masterphone hookswitch. This F-27-C handset is the same as that used with other Masterphones and is equipped with the Kellogg patented NON-POSITIONAL transmitter.

The ringer is the Kellogg non-adjustable, non-sticking type. Permanent magnets are of high quality steel, and

carefully wound high impedance coils with cores of soft annealed iron are used.

Kellogg generators are ruggedly constructed to withstand hard usage, and will give many years of service without attention. The 3-bar generator is designed for local lines having one or more telephones, or for lightly loaded rural lines. The 5-bar generator supplies ample current for long and heavily loaded rural lines. The mounting space required for this Wall Masterphone is 7½ inches by 10 inches.

A battery saver is not supplied with the 5809-M Masterphone unless specified.

Ordering Information

No. 5809-M, 1000 Ohm Ringer, 3-Bar Generator

For local lines with one or more phone and for lightly loaded farm lines.

No. 5812-M, 1600 Ohm Ringer, 5-Bar Generator

For long and heavily loaded lines.

No. 5816-M, 1600 Ohm Ringer, 5-Bar Generator

Condenser in receiver circuit. For ringing through heavily loaded lines even if receivers are down.

No. 5859-M, 2500 Ohm Ringer, 5-Bar Generator

For long and heavily loaded lines.

No. 5880-M, 2500 Ohm Ringer, 5-Bar Generator

Condenser in receiver circuit. For ringing through heavily loaded lines even if receivers are down.

Major Parts

Telephone Code No.	Ringer	Generator	Condenser	Shipping Weight Each, Lbs.
5809-M	78-A	15	none	15½
5812-M	78-D	53	none	18½
5816-M	78-D	53	200	18½
5859-M	78-G	53	none	18½
5880-M	78-G	53	200	18½

Parts Used in All of This Type Masterphone

Part No.	Description	Quantity Used
F-27-C	Handset	1
105-A	Induction Coil	1
165	Hookswitch	1

Compact Type Wall Telephones

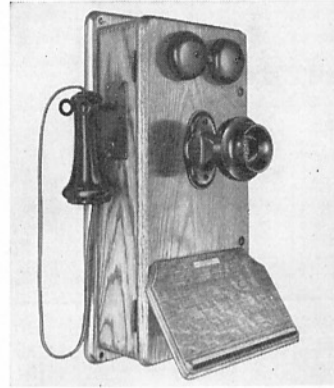

Kellogg compact type wall sets are complete with battery compartment and writing shelf. The transmitter and receiver are of the same high quality as those used in the Kellogg desk stand.

The ringer is Kellogg's famous non-adjustable, non-sticking type. Permanent magnets of high quality steel and carefully wound; high impedance coils assure response to the weakest current. The hookswitch assures

positive contact and will remain free from rattle.

The generator is ruggedly constructed to withstand hard usage and will give many years of service without attention. The 3-bar generator is designed for local lines having one or more telephones or for lightly loaded farm lines. The 5-bar generator will supply ample current for even the longest and most heavily loaded lines.

The attractive oak cabinet is compact, yet all parts contained within it are conveniently located and easily accessible.

The length is 19 inches; depth, 9¾ inches; width of backboard, 8¾ inches; width, including hookswitch and crank, 11¼ inches.

Ordering Information

No. 4809, 1000 Ohm Ringer, 3-Bar Generator

For local lines with one or more phones and for lightly loaded farm lines.

No. 4812, 1600 Ohm Ringer, 5-Bar Generator

For long and heavily loaded lines.

No. 4816, 1600 Ohm Ringer, 5-Bar Generator

Condenser in receiver circuit. For ringing through heavily loaded lines even if receivers are down.

No. 4880, 2500 Ohm Ringer, 5-Bar Generator

Condenser in receiver circuit. Same as No. 4816 except for ringer.

No. 4820, 1600 Ohm Ringer, 5-Bar Generator

Condenser and secret calling button with special pulsating and alternating current generator for secret signalling.

Major Parts

Telephone Code No.	Ringer	Generator	Condenser	Shipping Weight Each, Lbs.
4809	78-A	15	none	26
4812	78-D	53	none	29
4816	78-D	53	184	29
4820	78-D	59	184	29
4880	78-G	53	184	29

Parts Used in All Compact Types

Part No.	Description	Quantity Used
105-A	Induction Coil	1
F-41-A	Receiver	1
129	Hookswitch	1
121-C	Transmitter	1
50	Transmitter Arm	1

Telephone Section

KELLOGG TELEPHONES for SPECIAL APPLICATIONS

Kellogg Railway Telephones

These telephones and associated apparatus are specially designed for high efficiency and low transmission losses. Rugged apparatus and simple construction make for long

life and low maintenance cost under the hard service conditions of railway train dispatching.

F-2945 Wall Telephone



No. F-2945

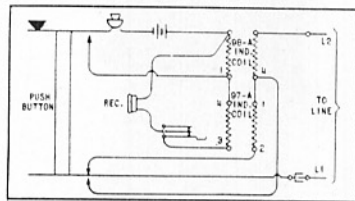

Schematic Circuit

The Kellogg F-2945 telephone is of the compact wall type, equipped with a five-bar generator, and a low wound, watch-case type receiver with leather-covered head band. It has sufficient space for three dry cells in the oak cabinet.

The circuit is designed to insulate the operator from any high potential line current. This is accomplished by the transformer being wired across the line ahead of the operator. Such arrangement permits a great number of telephones to be permanently bridged across the line, any or all of which may have their receiver off the hook without materially affecting the transmission efficiency.

The Kellogg F-2945 telephone is widely used at sidings, along right of ways, or similar places for the purpose of permitting conductors and trainmen to get into quick communication with dispatchers.

This telephone is drilled and wired for, but not equipped with a ringer unless specified.

Size is 23 inches high, 9 3/4 inches wide and 5 1/4 inches deep. Shipping weight is 30 lbs.

Major Parts

Part No.	Description	Quantity Used	Part No.	Description	Quantity Used
2	Head Band	.1	97-A and	Induction	
121-L	Transmitter	.1	98-A	Coil	.1
80-A	Receiver	.1	171	Condenser	.1
59	Push Button	.1	F-677-TR	Cord	.1
53	Generator	.1	50	Trans. Arm	.1
109	Hookswitch	.1			

No. 1 Type Foot Switch

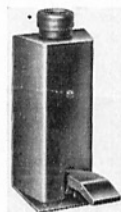

A sturdy, reliable unit covered with a black enameled steel cover. The malleable iron foot pedal is held in the non-operating position by a durable coil spring. Contact springs and terminals are insulated from the housing and foot pedal with Bakelite and micarta. Spring assemblies are mounted on the back of the housing, safe from water, snow or mud which might find entrance through the pedal slot.

The housing is 6 1/2 in. high, 3 in. wide and 2 3/8 in. deep. Including the pedal, the depth is 5 1/8 in. The shipping weight is 4 lbs.

Code No. Spring Combination

1-A		One make contact.
1-B		One make and one make and break contact.
1-C		One break, two make and one make and break contact.

F-601 Telephone — For Mounting

on Extension Arm

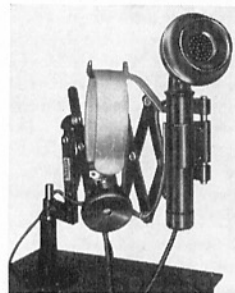

F-601 Telephone with ZA-25 Extension Arm

Particularly designed for railroad use. A low wound, watch-case type receiver with leather-covered head band is furnished unless otherwise specified. For use with desk set boxes containing special high efficiency transmission circuits, shown below. The terminals and hookswitch assembly are easily accessible. Standard spade tipped receiver and desk stand cords are furnished unless pin tips are specified. All parts are specially insulated.

Telephone Extension Arms

Two types are available, the ZA-29 and ZA-30 which raises, lowers, contracts or swivels and the ZA-25 and ZA-26 which extends in and out and swivels only. This extension arm is strong and durable and holds the telephone firmly and conveniently. Mounting brackets are listed below. Finish is black enamel.

Cat. No.	Length of Bracket,		Shipping Weight
	Extended		
ZA-29	32 in.		6 1/2 lbs.
ZA-30	36 in.		7 lbs.
ZA-25	34 in.		5 1/2 lbs.
ZA-26	38 in.		5 3/4 lbs.

Mounting Brackets

For attaching extension arms in various positions.

- No. ZA-36 For top of flat top desk.
- No. ZA-40 For side of desk or for wall mounting.
- No. ZA-38 For side of roll top desk.
- No. ZA-42 For window ledge, railing, etc.

No. 2413 Desk Set Box



Uses the same high efficiency circuit as is used in the F-2945 telephone. Equipped with a push button on the side of the oak cabinet. Arranged to operate with the No. F-601 bracket telephone or with a similar instrument of high efficiency. Nos. 97-A and 98-A Induction Coils, a No. 171 Condenser and a No. 53 Push Button are used.

Box is 7 in. high, 6 in. wide and 3 in. deep. Shipping weight is 7 lbs.

No. F-2414 Desk Set Box

Same as No. F-2413, except that it is not provided with push button and requires the use of No. 1-B foot switch.

No. F-4421 Generator Box

Usually used in connection with either the F-2413 or F-2414 desk set boxes and the F-601 telephone for signalling purposes when the dispatcher is not on the line.

Consists of a heavy duty 5-bar, No. 53 generator mounted in an oak cabinet. The cabinet is 10 1/4 in. high, 8 in. wide and 6 in. deep. Shipping weight is 17 lbs.

KELLOGG TELEPHONES for SPECIAL APPLICATIONS

Extra heavy duty telephones for use by power companies, oil field operators, pipe lines, railways, lumbering, irrigation and water systems, construction projects,

state and national parks, forestry service and other industries requiring high efficiency telephones.

Insulated Wall Type Telephones



The Kellogg F-1983 wall telephone is provided with the Kellogg standard magneto telephone circuit. All coil windings are vacuum impregnated for protection against moisture. The wiring is of braided rubber covered wire. All metal parts are insulated.

Dimensions: height, 10 $\frac{3}{4}$ in.; width, 8 $\frac{1}{2}$ in.; depth, 6 $\frac{1}{4}$ in. Shipping weight is 23 lbs.

Major Parts, No. F-1983

Part No.	Description	Part No.	Description
55-G	Ringer	F-41-A	Receiver
121-L	Transmitter	53	Generator
41	Trans. Arm.	103	Hookswitch
		108-A	Induction Coil

Heavy Duty, Wall Type Telephones



Three Dry Cell Cabinet Type

These two instruments are designed for heavy duty service and are widely used in oil fields, forestry service and by electric power companies.

No. 6884

Equipped with a 6-bar generator, 2500 ohm ringer and TRIAD circuit with insulated primary and secondary. Replaces No. 2884.

No. 6886

Equipped with a 5-bar generator, 2500 ohm ringer with 3-inch gongs, TRIAD circuit and No. 200, 1 MF condenser in the receiver circuit.

Size is 23 in. high, 9 $\frac{1}{4}$ in. wide and 5 $\frac{1}{4}$ in. deep. Shipping weight is 29 lbs.

Major Parts

Telephone Code No.	Ringer	Generator	Transmitter	Hook-switch	Receiver	Induction Coil
6884	78-G	75	121-C	163	F-41-A	111-A
6886	55-G	53	121-C	163	F-41-A	105-A

No. 5845 Wall Type Masterphone

Enclosed in oak finished cabinet. Equipped with No. 43-C handset and wired with the TRIAD anti-side tone circuit. Separate primary and secondary circuit.



Major Parts, No. 5845

Part No.	Description	Quantity Used
78-G	Ringer (2500 Ohm)	1
75	Generator (6 Bar)	1
F-43-C	Handset	1
165	Hookswitch	1
111-A	Induction Coil	1
200	Condenser	1
61217	Connecting Rack Assembly	1

Heavy Duty Masterphones

No. 951-LR

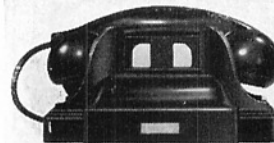

Similar to set No. 950-LR, shown on page 15, except it is wired with insulated primary and secondary circuits and is equipped with a 4-conductor handset and a No. 111-A induction coil.

May be used with No. F-2515 desk set box.

No. 951-C-LR

Same as No. 951-LR with condenser in receiver circuit.

No. F-2515 Desk Set Box

Equipped with a No. 78-G, 2500 ohm ringer and a No. 75, 6-bar generator.

Heavy Duty Pedestal Type Desk Sets

This desk type oil field telephone No. 90-A, may be used with No. 4415 desk set box shown below and gives the same service as the No. 6884 wall set described above.

The desk stand is 11 in. high and the desk set box is 10 $\frac{1}{4}$ in. high, 3 $\frac{3}{4}$ in. wide and 6 $\frac{1}{4}$ in. deep. The shipping weight of the stand is 5 lbs. and the box is 15 lbs.

No. 4415 Desk Set Box

Primary and secondary circuits insulated. No. 78-G, 2500 Ohm Ringer, No. 75, 6-Bar Generator and No. 108-A, Induction Coil, are used in this desk set box.

Masterphones

No. 952-LR

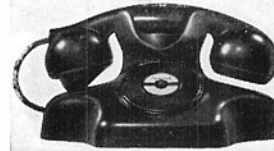

Equipped with special springs to operate central office drop. Uses a No. 109-A induction coil and a No. F-720-D desk set cord. Similar to 900 series of Masterphones shown on page 15.

No. 952-SA

Same as No. 952-LR but with No. 110-A, 1000 Ohm ringer.

Composite Wall Telephone

The No. F-2869 composite wall telephone is housed in a compact oak cabinet with dry battery compartment for 2 No. 6 dry cells and writing shelf. It has no generator or ringer but is designed to be used with a No. 5-A howler, and the signalling vibrator is operated with a push-button. Contains No. 121-L transmitter on No. 50 arm; No. 99 switch hook; No. 16-C retardation coil, 2 No. 25 condensers; No. 28 condenser, No. 14 push button; No. 66A induction coil interrupter; and No. F-41-A receiver. Baseboard 19 inches by 3 $\frac{3}{4}$ inches. Over-all depth, 9 $\frac{3}{8}$ inches.

Howlers

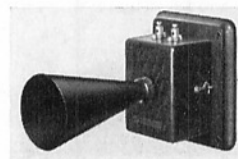

The No. 5-A Howler is used with composite telephones for railroad dispatching service. It consists of a heavy adjustable unit, wound to 1700 ohms and mounted in a compact oak cabinet. Dimensions of base, 5 $\frac{1}{8}$ x 6 inches. Overall height, including horn, 9 inches.

Note: Loud Ringing Bells are shown on page 33. Industrial Signals are shown on pages 82 and 83 of the Line Supplies Section.

Telephone Section

PORTABLE TELEPHONES

Linemen's 1025 Test Set

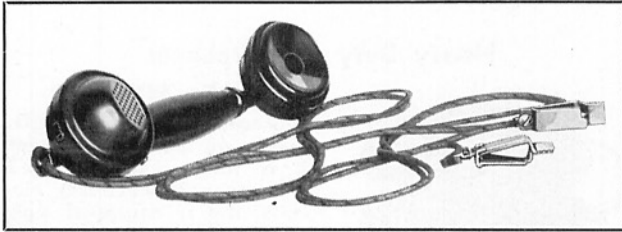

The Kellogg 1025 compact, easy-to-carry linemen's testing and talking set is designed for use on common battery lines. It is a very desirable accessory to the line-man's repair kit. When used as a talking set Central can be reached by simply "clipping" in at the main frame, the terminal rack, or out on the line.

The set consists of a Kellogg No. 19 handset with transmitter and receiver in series and two single conductor cords, 62 inches long, equipped with two No. 27 Universal test clips. The handset is made entirely of metal, black enameled with the exception of the hard rubber ear cap. Equipped with the famous Kellogg NON-POSITIONAL transmitter unit.

Shipping weight is 3 lbs.

Piece Parts

Part No.	Description	Quantity Used	Part No.	Description	Quantity Used
36181	Receiver Assem.	1	36263	Handle	1
43754	Trans. Back	1	43864	Cord Assem.	2
36230	Trans. Cup Ins.	1	27	Mueller Universal Clip	2
115-L	Trans. Assembly	1	36189	Screw	4
36260	Trans. Front	1			

Kellogg 3001 Type Portable Telephone

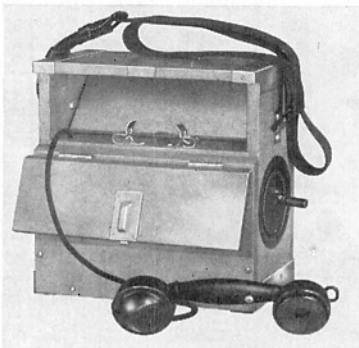

The Kellogg No. 3001 Portable Telephone meets every service requirement where a simple rugged set is required. It will talk and ring over the longest and most heavily loaded line. It is durable and compact — built to withstand hard usage, yet light enough to be easily transported in trouble cars. The net weight is 19 pounds.

This telephone is equipped with a metal handset, which contains the NON-POSITIONAL transmitter and a high-grade receiver unit. Battery current is supplied by a standard 3-cell flashlight battery. A button in the handset cuts in the battery when talking.

This set is equipped with a Kellogg standard 2500 ohm ringer, a powerful 5-bar generator, one-half microfarad condenser, and an accurately balanced induction coil. Connections to the line are made direct to two heavy contact clips.

The cabinet is varnished birch with heavy brass reinforcements, equipped with a 54-inch adjustable carrying strap, 1 1/8 inches wide.

Dimensions: 10 1/4 in. high, 10 in. wide, 5 in. deep. Shipping weight, 29 pounds. Shipped less battery.

Major Parts

No. Part	Description	Quantity Used	Part No.	Description	Quantity Used
86	Generator	1	32-L	Handset	1
F-108-A	Induction Coil	1	28	Condenser	1
109-G	Ringer	1	39420	Crank Assem.	1

Kellogg 3025 Type Lightweight Portable Telephone

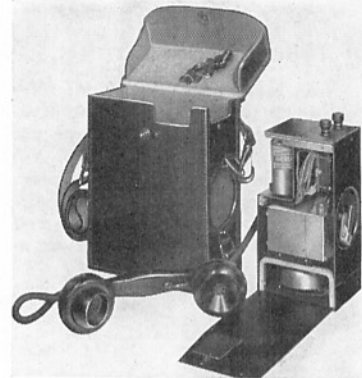

This instrument is very compact and light, is easily set up and will talk and ring efficiently over long, heavily loaded lines. It weighs only 10 pounds, including the leather case and strap, yet it is ruggedly built for hard service. It comes with a standard Kellogg Masterphone handset of moulded Bakelite construction, containing a capsule

type receiver with cobalt steel magnet, a high efficiency NON-POSITIONAL transmitter and a thumb-operated switch in the handle for use in cutting in the talking current. Two heavy brass bars moulded throughout the length of the solid Bakelite handle reinforce the handle and carry the current between both ends.

All equipment, including the condenser, coil, generator, buzzer and space for two standard flashlight batteries (Eveready No. 950 or equal), is contained in an aluminum alloy housing with a Bakelite top piece. The generator is rugged and compact and has an unusually high output. The folding crank is outside of the case which permits the telephone to be used in bad weather with the case entirely closed.

Size is 9 3/8 in. high, 8 1/8 in. wide and 3 7/8 in. deep. Shipping weight 10 1/2 pounds.

Ordering Information

Code No.	Description
3025	Complete with Ringer and Generator
3025-LR	Less Ringer
3025-LG	Less Generator
3025-LRG	Less Ringer and Generator

Major Parts

Part No.	Description	Quantity Used	Part No.	Description	Quantity Used
F-44-L	Handset	1	61485	Cord Assembly	1
61847			109-A	Ind. Coil	1
& 15911	Crank Assem.	1	118-G	Ringer	1
950	Dry Cells	2	202	Condenser	1
105	Generator	1	61858	Case Assembly	1

No. 1016 Test Set

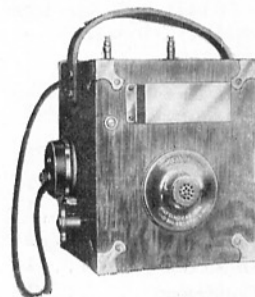

The Kellogg 1016 test set is a complete portable telephone, sturdily constructed and will talk and ring over the longest and most heavily loaded lines. It is equipped with a powerful Kellogg 5-bar generator, 1600 ohm ringer, long distance transmitter, head receiver, induction coil, hookswitch and two No. 4 dry cells. The oak cabinet is strongly reinforced with metal corners.

Size is 8 in. high, 7 in. wide and 8 3/4 in. deep. The shipping weight is 18 pounds. Net weight is 15 pounds.

WEATHERPROOF TELEPHONES and LOUDRINGING BELLS

Kellogg Weatherproof Telephones

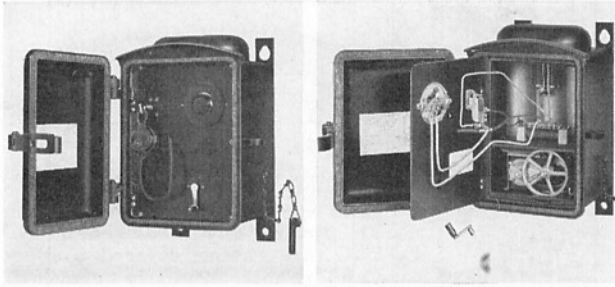

This rugged telephone is designed for outdoor locations where a magneto telephone is required. It represents the best in transmission, reception and ringing efficiency. The set is sealed against the entrance of rain or snow, but the cast-iron housing is ventilated to prevent condensation of moisture. All parts are treated to resist corrosion; the housing is painted black.

The housing has a cast-in shelf for three dry batteries. Ample space is provided for the standard Kellogg 5 or 6-bar generator which mounts on a sliding Bakelite shelf and is easily removed for inspection. A Kellogg standard non-adjustable 2500-ohm ringer is used and the 3-inch adjustable brass gongs extend through the top of the housing, protected by a heavy steel hood. The silicon steel induction coil which mounts the connecting rack is fastened to another sliding Bakelite shelf and also provides space for a condenser when specified. The highly efficient Kellogg transmitter and the watch case type receiver with cobalt steel magnets are both mounted on the inner door. Simplified wiring is used throughout. The inner door swings out, giving free access to all parts.

There is a hole in top of case, tapped for standard 1/2-inch pipe fitting. Slotted screw holes in the mounting straps permit the setting of the upper lag screws before the housing is hung in place. The entire telephone may be handled and installed by one man. The cast-iron door is equipped with reinforced hinges and a heavy-duty clasp . . . can be locked with a standard padlock.

Dimensions: Height is 14 1/8 inches; width, 11 5/8 inches; depth, 10 1/4 inches. The shipping weight of No. 4883 is 69 pounds and No. 4888, 73 pounds. Horizontal mounting centers, 7 5/16 inches, vertical 14 1/4 inches.

Ordering Information

No. 4883, With 5-Bar Generator, 2500 Ohm Ringer.
No. 4888, With 6-Bar Generator, 2500 Ohm Ringer.

Major Parts, No. 4883

Part No.	Description	Quantity Used
56981	Inner Door Assembly	1
55-G	Ringer	1
53	Generator	1
121-L	Transmitter	1
159	Hookswitch	1
81-A	Receiver	1
682-TR	Receiver Cord	1
100-A	Induction Coil	1

Major Parts, No. 4888

Same as No. 4883 except that 6-bar generator, No. 75, is used.

Weatherproof Loudringing Bells

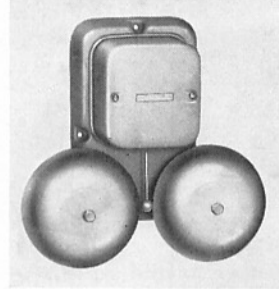

For indoor or outdoor use with either common battery or magneto service. Especially adapted for taxi stands, coal yards, lumber yards, police or fire alarms and all other places where loudringing weatherproof bells are required. These bells are completely weatherproof and operate perfectly under any climatic condition. They are sturdily constructed, dependable and efficient and guaranteed to give many years of satisfactory service with practically no maintenance.

Either straight line or harmonic ringers can be furnished with these bells. The rugged, 6-inch cadmium plated steel gongs are easily adjusted. The housing consists of a heavy cast iron base with a removable cast-iron cover, all finished with a durable coat of gray zinc paint.

These bells can be mounted in a few minutes with three ordinary screws or bolts. Outside mounting holes eliminate removing the cover upon installation. Size overall is 13 in. wide, 12 1/2 in. high and 4 1/2 in. deep. The shipping weight is 14 pounds each.

Ordering Information

No. 65-SA. 1000 Ohm Ringer, straight line type. No condenser unless specified.

No. 65-SD. 1600 Ohm Ringer, straight line type. No condenser unless specified.

No. 65-SG. 2500 Ohm Ringer, straight line type. No condenser unless specified.

No. 65-HB. Harmonic Ringer, frequency of 30, 42, 54 or 66 cycles. Furnished with No. 12, 1 MF condenser.

No. 65-HA. Harmonic Ringer, frequency of 33 1/2, 50, 66 2/3 or 16 2/3 cycles. Furnished with No. 12, 1 MF condenser.

When a condenser is required with straight line ringers order one No. 12 condenser, one No. 3460 mounting strap and two No. 57238 screws.

Magneto Extension Bells

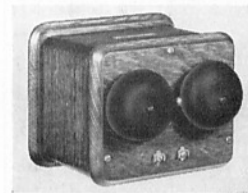

The Kellogg 37 type magneto extension bell consists of a small, neat oak cabinet with ringer and two binding posts. The ringer is the No. 78 non-adjustable armature type and is extremely efficient. It responds to the weakest current, yet will not freeze or stick. Coils are accurately wound with highest grade copper wire. The brass bells are finished in heavy, black enamel. Cabinet is 5 1/2 in. high, 6 3/8 in. wide and 4 3/4 in. high. Shipping weight is 3 pounds each.

Ordering Information

Code No.	Resistance	Description
37-SA	1000 Ohms	Straight Line
37-SD	1600 Ohms	Straight Line
37-SG	2500 Ohms	Straight Line
37-BA	1000 Ohms	Biased Ringer
37-HB	Harmonic	30, 42, 54 or 66 cycles

Condensers are not supplied with these bells.

Telephone Section

KELLOGG HANDSETS

Kellogg Masterphone Handsets

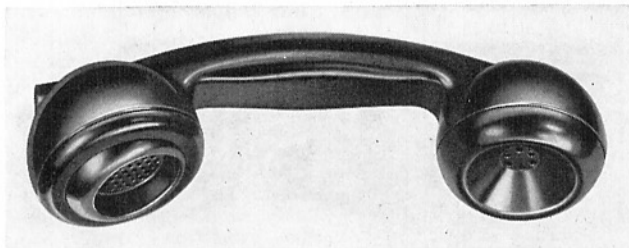

These Kellogg handsets are all-Bakelite and are equipped with patented NON-POSITIONAL transmitters and bi-polar type receivers, using cobalt magnets.

Both transmitters and receivers are of the capsule type with bayonet clips. Two brass bars molded into the Bakelite handle serve as conductors to the receiver and also act as reinforcements for the Bakelite handle. Cord connections are easily made in the transmitter cup. These handsets are shipped with cords attached.

The length of these handsets is 9 inches and the shipping weight of each is 1½ lbs.

Ordering Information

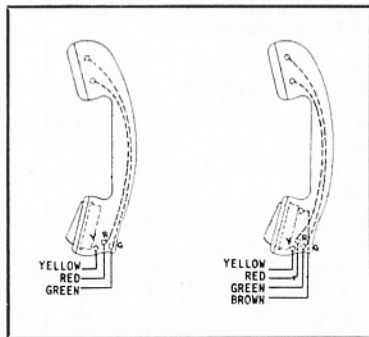

Wiring Diagrams: No. F-27-C is shown at left and Nos. F-39-C, F-40-C and F-43-C at right.

No. F-27-C

Standard handset for Masterphones. 3-conductor cord. For complete piece parts see page 23.

No. F-39-C

A four-conductor handset with transmitter and receiver conductors separate. Fits No. 145 plug — for use as operator's handset. Also available with cord to fit Nos. 182 or 139 operator's plug. Specify type of plug used.

No. F-40-C

A four-conductor set, for attachment to wall telephones in place of the transmitter and receiver, without changes in the internal wiring. See Conversion Kits on page 37.

No. F-43-C

Used with No. 5845 telephones. Same as F-40-C, except cord conductor lengths are 6½ in. on telephone end. Used in telephones where the complete separation of receiver and transmitter circuits is required.

The above sets are available with low resistance transmitters for special applications. When ordering substitute "L" for "C" in the code No. of the handset required.

Major Parts

Nos. F-27-C, F-39-C, F-40-C and F-43-C use the same parts except for the cord. Nos. F-39-C, F-40-C and F-43-C have one clip omitted from the transmitter. Complete piece part information is shown on page 23.

Code No. of Handset	Transmitter	Receiver	Cord	Use
F-27-C	57340	55919	F-673-G	Masterphones
F-39-C	57340	55919	F-698-G	Operator's Handset
F-40-C	57340	55919	F-699-G	Conversion Unit
F-43-C	57340	55919	F-734-G	4-Conductor Handset

Bakelite Handset — With Switch



No. 44-C Handset

Equipped with switch in handle for use with the No. 3025 Portable telephone. Four-conductor cord No. F-735-G with rubber covered conductors and rubber sheath is furnished.

This No. 44-C handset is all Bakelite and has the capsule type NON-POSITIONAL transmitter and bi-polar receiver, the same as No. F-27-C.

Length of handset is 9 in. and shipping weight is 1½ lbs.

Major Parts — Handset 44-C

Part No.	Description	Quantity Used	Part No.	Description	Quantity Used
60942	Body Assembly	1	60849	Term. Assem.	1
55919	Receiver Assem.	1	60939	Screw	1
62505	Mouthpiece	1	61179	Screw	2
55369	Ring	1	60788	Screw	1
58028	Ear Cap	1	57340	Transmitter	1
58015	Diaphragm	1		Assembly	1
60943	Switch Assembly	1	F-735-G	Cord	1

Metal Handsets

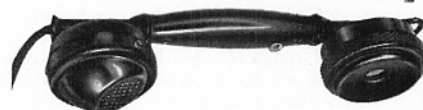

No. 22-C Handset

These metal handsets use the same high efficiency, NON-POSITIONAL, capsule type transmitter and bi-

polar, capsule type receiver as are used in the regular Bakelite handsets. They are somewhat smaller and more compact, adapting them to some uses where space is not available for the slightly larger Bakelite sets and the transmitter has screw connections instead of clips. These handsets are shipped with cords attached.

The finish is black, baked enamel. Length of handset is 8½ in. and shipping weight is 1½ lbs.

Major Parts

Code No. of Handset	Cord	Transmitter	Receiver	Description
19-L	F-664-G	115-L	36181
22-C	F-621-G	115-C	44405	Switch in Handle
32-C	F-688-G	115-C	44405	Switch in Handle, Used in No. 3000 Telephone

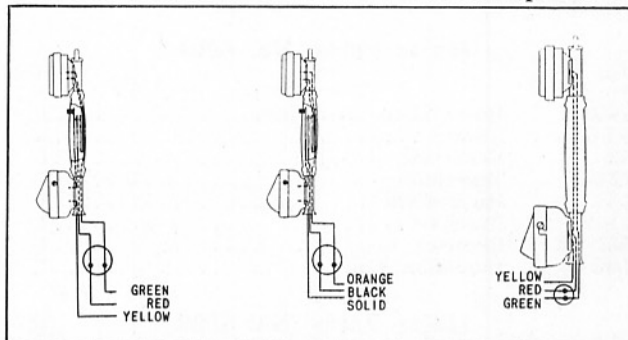

Wiring Diagrams: No. 19-L is shown at left, No. 22-C in the center and No. 32-C at right.

KEY BOXES and WALL OUTLET PLUGS and JACKS

Bakelite Key Boxes

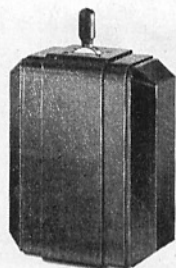

A compact, attractive key box that makes an ideal installation for any location. Made of moulded Bakelite, the sturdy housing will retain its rich, black lustre permanently. It contains all the equipment and mounts on a nickel-plated steel back plate. A simple, positive locking catch rigidly secures the housing to this back plate.

This key box can be mounted in any position — flat, upright, or on its side. The back plate is simply attached to the wall or desk with two screws. Since all of the

equipment is in the housing, connections are easily and conveniently made before the unit is snapped into place.

All wires in the unit terminate in soldered tips fastened under screw terminals on the connecting racks. The racks are clearly numbered and easy to get at. There are extra terminals on each rack which can be used to terminate bell, buzzer or other circuits that are independent of the switching key. These extra terminals can also be used where special spring arrangements are desired. Line wires enter the key box through an opening in the bottom.

Standard Kellogg keys are used in these key boxes. They are rugged and simple and have long, heavy, evenly shaped and properly tempered springs of nickel silver; precious metal contacts; heavy "T" shaped brass frame to which the springs are rigidly mounted; long life cam and pivot rollers upon which depend smooth operation without wear; felt dust protecting cushion, and extra heavy insulations. All Kellogg springs are heavily insulated with micarta and withstand the most severe breakdown test.

These key boxes are 5½ in. high, 3¾ in. wide, and 1½ in. deep. Shipping weight each is 1 lb.

No. 12 — Two-Way

Wired to switch a telephone to either of two incoming lines. The key locks in two positions. Circuit diagram is shown below.

No. 13 — Three-Way

Similar to No. 12, except it switches a telephone to one of three lines. The key locks in all three positions. Often used with systems having two trunks and a separate circuit for intercommunication. Circuit diagram is shown below.

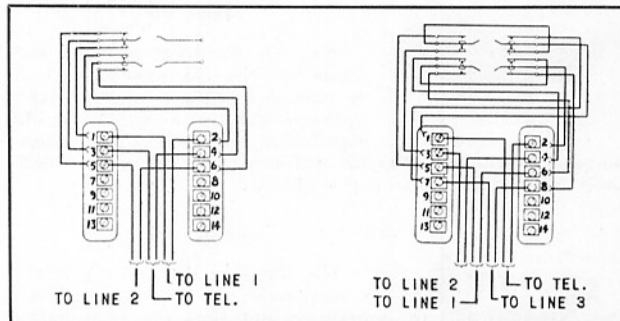

Wiring diagram at left shows switching arrangement for No. 12, Key Box and right-hand diagram shows No. 13.

Major Parts

No. 12			No. 13		
Part No.	Description	Quantity Used	Part No.	Description	Quantity Used
60287	Cover Assembly	1	60287	Cover Assembly	1
60286	Conn. Rack		60286	Conn. Rack	
	Odd Nos.	1		Odd Nos.	1
60283	Base Assembly	1	60283	Base Assembly	1
1028	Key	1	1030	Key	1
60457	Conn. Rack		60457	Conn. Rack	
	Even Nos.	1		Even Nos.	1

Wall Outlet Plugs and Jacks

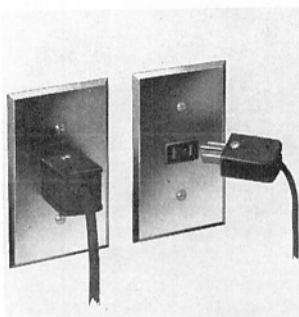

Flush Mounting Type

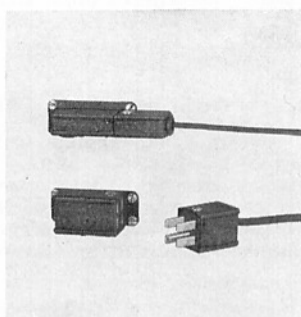

Surface Mounting Type

Plug and jack outlets for portable telephones provide extra profit to the telephone company and more convenient service to the subscriber. They are extremely economical and are easily installed wherever desired. They enable the subscriber to carry the telephone from room to room and in addition to the rental of these outlets each installation can result in the sale of one or more portable telephones at regular extension rates.

The jacks come in two styles, for flush and for surface mounting. Both types are available for 2, 3 or 4 conductors. Corresponding plugs are the same for both types. The plugs are polarized and cannot be incorrectly inserted in the jacks. They provide for a tie cord and

take standard spade cord tips. Plug bodies are of molded plastic with metal covers, durably finished in black.

Plug body for 3 and 4-conductor is 1 x 1 x 1¼ inches and for 2-conductor, 1 x 1¼ x ½ inches.

Flush Mounting Type

Brushed brass mounting plates are the same size as conventional electric outlet plates and are furnished with each flush mounting jack. The simple jack assembly fits standard electric switch or outlet boxes. Line wires solder to jack terminals or can be fastened to terminals with No. 6 screws and nuts. Ordering information below.

Surface Mounting Type

Easily and inexpensively installed. They fasten to any convenient location with wood screws. The width and height of the jack housing are the same as the width and height of the plug. The plug is inserted at the side for minimum projection.

Ordering Information

2-Conductor

Code No.	Description	Price
402	Jack complete with flush-mounting plate	.85
412	Jack for surface mounting	.95
302	Plug for use with either of above jacks	.35

3- and 4-Conductor

404	Jack complete with flush-mounting plate	.95
414	Jack for surface mounting	1.05
304	Plug for use with either of above jacks	.45

Telephone Section

BINDING POSTS, CONNECTOR BLOCKS, etc.

Binding Posts

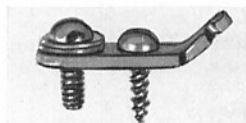

No. 11

No. 11 binding post is made of tin-plated brass. Its small size adapts it to a wide variety of uses. It is made to take spade tips. One No. 4482 wood screw is furnished for mounting. Dimensions of the base are $\frac{5}{16}$ inch by 1 inch.

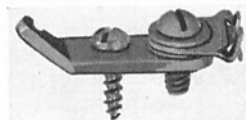

No. 76

No. 76 binding post is the same as No. 11 except that it is provided with a clip to take spike or pin tips as well as spade tips. The clip makes this binding post more desirable for universal use. One No. 4482 wood mounting screw is furnished.

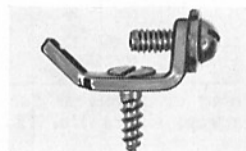

No. 59

No. 59 is of the same general construction as No. 11 binding post except that the connection is made at right angles to the base. One No. 11033 wood mounting screw is furnished. Dimensions of the base are approximately $\frac{5}{16}$ inch by $\frac{3}{4}$ inch.

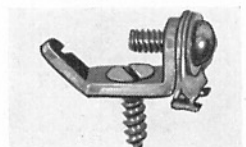

No. 63

No. 63 is identical with No. 59 except that it is provided with a clip to take spike or pin tips. A very satisfactory binding post for universal use. One No. 11033 mounting screw is furnished.

Telephone Tools



No. 9

Flat wrench for $\frac{1}{4}$ and $\frac{3}{8}$ inch ringer nuts.



No. 10

Flat wrench for $\frac{1}{4}$ and $\frac{3}{8}$ inch ringer nuts.



No. 59

Flat wrench for $\frac{3}{8}$ and $\frac{5}{8}$ inch ringer nuts.

No. 52



Desk stand spring adjuster.



No. 71

Used for removing the Masterphone transmitter ring and receiver cap. Also valuable aid in removing caps from other types of receivers.

Kellogg Connector Blocks

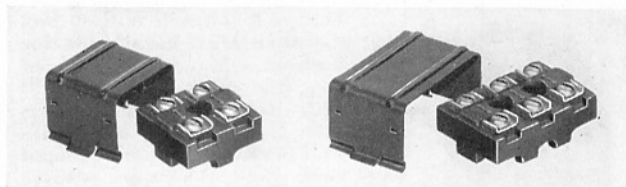

No. 25-A, Rack and Cover — Two Point

No. 25-B, Rack and Cover — Three Point

Kellogg Connector Blocks are one-piece, made of moulded Bakelite and take every type of cord tip and all sizes of wire. When used for connecting the telephone cord to the line wire leads, connections may be made quickly and easily, eliminating the nuisance of soldering and taping.

The blocks may be attached in any position and in almost any place with ordinary wood screws. Counter-sunk screw holes eliminate the possibility of shorts across the screw heads. The neat, compact appearance of these blocks makes them unobtrusive wherever they are used.

As all metal parts are Everdur mounted in Bakelite, there can be no rust, corrosion or shorts. The connector bars are moulded right in the Bakelite so that they cannot loosen and come off. Lugs act as reinforcements and provide means to fasten stay cords. Deep slots in the Bakelite base hold cord tips in position, guard against lateral movement of cord tips and prevent loosening of screws.

Furnished with or without "Snap-on" Everdur cover. Specify when ordering.

Ordering Information

No.	Description
25-A	Two-Point Block for connecting up two wires. Less Cover.
58887	Cover for 25-A.
25-B	Three-Point Block for connecting up three wires. Less Cover.
58889	Cover for 25-B.

Transmitter Type Number Plates

No. 88 number plate is held in place by two transmitter back screws, 5191. It is made of steel, heavily black enameled. Clear, transparent celluloid is used to protect the white card which is furnished blank. Mounting holes are at a 90 degree angle. Mounts on most standard makes of transmitters.

Battery Saver



The principle of the Kellogg No. 1 battery saver is extremely simple. It stops the receiver hook after it has closed the receiver contact, but before the battery contact has been closed, thus permitting reception without the use of batteries. Pressing the stop lever releases the receiver hook which closes the battery contact permitting complete conversation. Net weight is 3 ozs.

CONVERSION KITS

Surplus idle wall telephones, accumulating in the stockroom, can be quickly and easily converted to modern attractive wall Masterphones and placed in profitable service. Each Masterphone conversion gives new "sales appeal" to the instrument. It puts idle wall phones into service.

A Masterphone Conversion Kit consisting of a few parts, together with an ordinary screw driver, a pair of long nose pliers, a hammer and a soldering iron are the only things necessary to complete the job.

Kit No. 1

For converting No. 801 wall telephones to wall Masterphone handset instruments.

Consists of:

- 1 No. F-27-C Handset, NON-POSITIONAL Trans.
- 1 No. 154 Hookswitch Assembly
- 1 Form 1438 Designation Strip
- 1 Number Plate Assembly including:
 - 1 No. 42081 Holder
 - 1 No. 56437 Dial
 - 1 No. 56445 No. Plate
 - Blank
 - 1 No. 42083 Protector
 - 1 No. 56000 Screw
- 1 No. 56442 Clamp
- 2 No. 56462 Screws

Kit No. 1-A

Same as Kit No. 1 except furnished with No. P-62116 Cover Plate instead of Number Plate Assembly.

Consists of:

- 1 No. F-27-C Handset, NON-POSITIONAL Trans.
- 1 No. 154 Hookswitch Assembly
- 1 Form 1438 Designation Strip
- 1 No. 62116 Cover Plate

This kit is especially recommended for conversion of No. 803 and 807 dial type steel wall telephones.

Kit No. 2

For converting No. 742 wall telephones to wall Masterphone handset instruments. Consists of the same parts as used in Kit No. 1 except for the designation strip which is Form No. 1439, especially marked for No. 742 instruments.

Kit No. 2-A

Same as Kit No. 2 except has No. 62116 Cover Plate instead of Number Plate Assembly.

Consists of:

- 1 No. F-27-C Handset, NON-POSITIONAL Trans.
- 1 No. 154 Hookswitch
- 1 Form 1439 Designation Strip
- 1 No. 62116 Cover Plate

Kit No. 10

Same as Kit No. 7 except provided with No. 62116 Cover Plate instead of ES-2410. For use with steel sets having transmitter arm lugs embossed in cover. Specially adapted to convert Nos. 803 and 807 dial type wall telephones to wall Masterphone handset instruments.

Consists of:

- 1 No. 40-C Handset, NON-POSITIONAL Trans.
- 1 No. 56280 Switch Hook Lever
- 1 No. 62116 Cover Plate



These pictures show Kellogg No. 801 wall type telephone before and after conversion to modern wall Masterphone handset type instrument. Conversion Kit No. 1 was used.

Kit No. 6

For converting all makes of desk set boxes to the Kellogg TRIAD circuit to correspond to Kellogg No. 610 desk set boxes. The mounting space required for these parts is $4\frac{1}{2} \times 3 \times 2\frac{1}{2}$ inches.

Consists of:

- 1 No. 103-A Induction Coil
- 1 No. 185 Condenser
- 2 No. 56152 Condenser Brackets
- 4 No. 5376 Screws
- 2 No. 27787 Screws
- 1 Circuit Label No. 21070

Kit No. 7

For converting wall magneto telephones into wall Masterphone handset instruments. The conversion may be made without removing the telephone from the wall.

Consists of:

- 1 No. 40-C Handset, NON-POSITIONAL Transmitter
- 1 No. 56280 Switch Hook Lever
- 1 ES-2410 Cover Plate

Kit No. 8

Same as Kit No. 7 with the addition of a complete hookswitch assembly, No. 155 to replace present hookswitch assembly not adapted to the Masterphone switch hook lever.

Consists of:

- 1 No. 40-C Handset, NON-POSITIONAL Transmitter
- 1 No. 155 Hookswitch Assembly
- 1 ES-2410 Cover Plate

Kit No. 9

For converting magneto sets to common battery sets. With this kit it is possible to convert your magneto set to common battery by removing the induction coil and condenser and rewiring the instrument according to circuit No. 21045 included with the kit.

Consists of:

- 2 No. 56152 Brackets
- 1 No. 177 Condenser
- 2 No. 27787 Screws
- 1 No. 99-A Induction Coil
- 4 No. 6011 Screws
- 1 Circuit Label No. 21045

Kit No. 11

For converting No. 817 TRIAD circuit steel wall telephones to No. 9817 wall Masterphone handset instruments.

Consists of:

- 1 No. F-27-C Handset, NON-POSITIONAL Trans.
- 1 No. 56280 Switch Hook Lever
- 1 No. 62116 Cover Plate

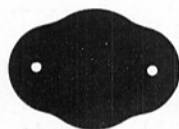

No. ES-2410
Cover Plate



No. 62116
Cover Plate

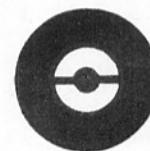

Number Plate
Assembly

Telephone Section

KELLOGG CONDENSERS

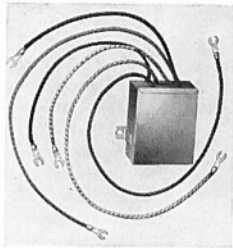

Kellogg condensers are manufactured in Kellogg's own plant by the most modern processes and with the best materials obtainable and under the supervision of Kellogg's own engineers. The foil and paper are the finest the market affords. The impregnating compound is

a special formula developed after years of laboratory research. To insure long life a special sealing compound is used. This compound will not crack at 0 degrees nor flow at 150 degrees Fahrenheit.

Kellogg condensers are made to meet the maximum voltage that may be required in the class of work for which they are designed, and are modern and compact with no sacrifice in efficiency.

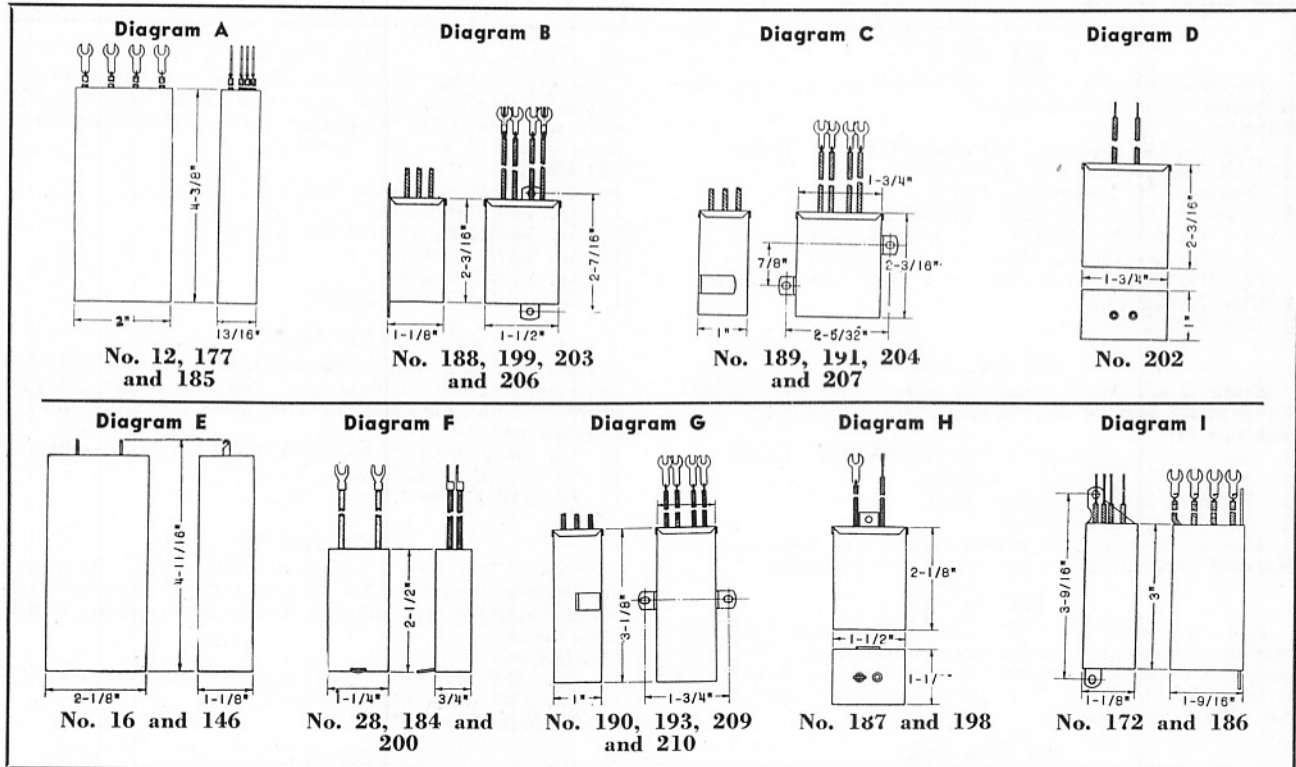

The diagrams above are to show dimensions and mounting information only

In the following table "Solder Lugs" refers to fixed terminals as shown in Diagram E. "Spade" refers to flexible leads terminating in Spade Tips as shown in Diagram F, G, etc. "Bare" refers to flexible leads terminating in bare wires as shown in Diagram I.

"Miscellaneous Telephones" refers to wall and desk telephones still in service but no longer of current manufacture.

Condenser No.	Diagram	Used In	Windings	Capacity MF	No. of Leads	Type of Tips
12	A	Misc. Telephones	1	1	2	Sold'r Lugs
16	E	Misc. Telephones	1	2	2	Sold'r Lugs
28	F	Misc. Telephones	1	1/2	2	Sold'r Lugs
53	..	97 Desk Stand	1	2	2	Sold'r Lugs
146	E	1	1	2	Sold'r Lugs
171	..	2945 Tel.	1	1/2	2	Sold'r Lugs
172	I	4900 Ser. Tel., F-429 D. S. Box	1	1	2	Spade
177	A	F-602 D. S. Box	1	1	2	Spade
184	F	3800, 4800 & 5800 Series Tels.	1	1/2	2	Spade
185	A	817, 9817 Tels., 610 D. S. Box	2	1-2	4	Spade
186	I	9710 Tel.	2	1-2	4	Spade
187	H	9720, 9740 Tels.	2	1-1 1/2	4	Spade (3)
188	B	925 Series Tel.	2	1-1 1/2	4	Spade
189	C	9900, 9917 Tels., 700 D. S. Box	2	1-1 1/2	4	Spade (3)
190	G	900 Ser. Tel.	2	1-1 1/2	4	Spade
191	C	705 D. S. Box	1	1	2	Spade
193	G	950-LR Tel.	1	1	2	Spade
198	H	9830 Tel.	1	1	2	Spade (1)
199	B	930-LR Tel.	1	1	2	Spade
200	F	6888 Tel.	1	1	2	Spade
202	D	3025 Tel.	1	1	2
203	B	925-X Series	3	1-1-1 1/2	6	Spade
206	B	Telephones	3	1-1-1 1/2	6	Spade
204	C	9917-X & 9900-X	3	1-1-1 1/2	6	Spade (4)
207	C	Ser. Tels.	3	1-1-1 1/2	6	Spade (4)
209	G	900-X Series	3	1-1-1 1/2	6	Spade
210	G	Telephones	3	1-1-1 1/2	6	Spade

KELLOGG INDUCTION COILS

For Magneto Telephones

No. 108-A

A two winding local battery induction coil of the latest design for well balanced transmission and reception. Used in Kellogg 2800 series telephones and 2300 series desk set boxes. Replaces No. 28-C induction coil but is also an excellent replacement in all types of magneto wall and desk telephones using two winding coils. Dimensions are 4¼ in. long, 1 in. deep and 1 in. high.



No. F-108-A

A two winding local battery induction coil, same as No. 108-A, except arranged for mounting in No. 3001 type portable telephones. Dimensions are 3¾ in. long, 1 ⅜ in. deep and 1 in. high.

No. 100-A

A combined two winding local battery induction coil and 7 point connecting rack providing for line and cord terminals. This coil is used in Kellogg 3800-M series of magneto wall Masterphones. Makes a convenient replacement unit for rebuilt old type telephones and desk set boxes. Dimensions are 4¼ in. long, 1½ in. deep and 1¼ in. high. Distance between mounting centers is 3¾ in.



No. 105-A

A three winding local battery induction coil for use with the Kellogg TRIAD anti-side tone circuit, equipped with 8 point connecting rack. Used in the Kellogg 4800 series of wall telephones and 5800 series of magneto wall Masterphones. May also be used to advantage in converting old telephones to the TRIAD circuit. Similar to No. 100-A, illustrated above. Dimensions are 4¼ in. long, 1½ in. deep and 1¼ in. high.

No. 109-A

A three winding, closed core, local battery induction coil with 5 point connecting rack, used in Nos. 950-LR, 930-LR, and 9837 Kellogg TRIAD circuit Masterphones. Dimensions are 3 in. long, 1 in. deep and 2¼ in. high.

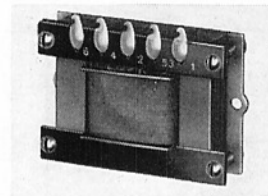

No. 111-A

A three winding, closed core, local battery induction coil with separate primary and secondary circuits. Has 6 point connecting rack. For use in No. 951-LR Masterphones with 4-conductor handsets. Similar to No. 109-A, illustrated above. Dimensions are 3 in. long, 1 in. deep and 2¼ in. high.

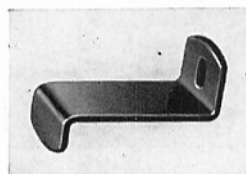

Piece No.	Thickness of Condenser	Piece No.	Thickness of Condenser
5771	¾ inch	27928	1½ inches
5772	1⅜ inches	4854	2⅜ inches

For Common Battery Telephones

No. 79-A

A two winding, common battery induction coil used in booster circuit, Nos. 801 and 803 wall telephones and No. 600 desk set boxes. Dimensions are 4½ in. long, 1 ⅜ in. deep and 1 in. high. Distance between mounting centers is 3⅞ in.



No. 51-A

A two winding, common battery induction coil used in the base of No. 97 desk stands wired with booster circuit. Similar in design to No. 79-A but with flexible leads. Size, 4½ in. long, 1 in. deep, 1 ⅜ in. high.

No. 99-A

A two winding, local battery induction coil, similar to No. 79-A but equipped with 7 point connecting rack. Used in Kellogg Nos. 805 and 807 wall telephones and No. 602 desk set boxes employing "simplified wiring". Dimensions are 4¼ in. long, 1½ in. deep and 1¼ in. high. Distance between mounting centers is 3²⁵/₃₂ in.

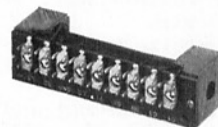

No. 103-A

A three winding, common battery induction coil with 9 point connecting rack, used in Nos. 817 and 9817 steel wall telephones and No. 610 desk set boxes wired with the Kellogg TRIAD anti-side tone circuit. Similar to No. 99-A, illustrated above. Size, 4¼ in. long, 1½ in. deep and 1¼ in. high.

No. 106-A

A three winding, closed core, common battery induction coil, with 6 point connecting rack. Used in all Kellogg common battery, moulded Bakelite handset Masterphones. Furnished with two screw connections to obtain greater side tone reduction when required. Dimensions are 3 in. long, 1 in. deep and 2¼ in. high.

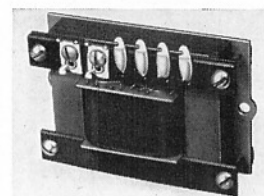

Induction Coils for Railway and Dispatching Telephones

No. 97-A and 98-A

These two induction coils are furnished as a set for use in high impedance dispatching telephones No. F-2945 and in Nos. F-2413 and F-2414 railroad dispatching desk set boxes. No. 97-A is 4¾ in. long, 1 ⅝ in. high and 1½ in. deep. No. 98-A is 3¾ in. long, 1¼ in. high and 1 in. deep.

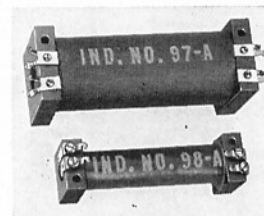

Condenser Mounting Brackets

Telephone Section

KELLOGG GENERATORS

Kellogg Generators

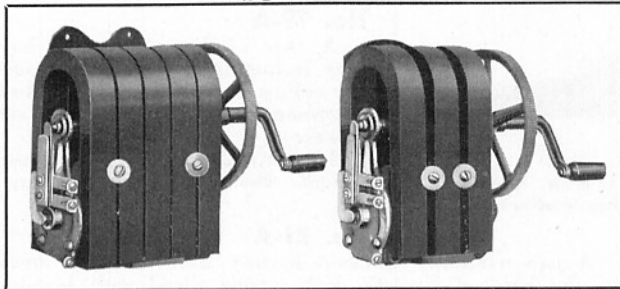

No. 53, 5 Bar

No. 15, 3 Bar

The secret of the Kellogg generator's extraordinary strength lies not only in its permanent magnet, but in the superior design of its revolving electro-magnet or armature, upon which the wire is wound.

The Kellogg armature is of the shaftless type, allowing plenty of winding space and the maximum amount of iron in the core.

All generator parts are well protected from rust and corrosion. Magnets are given a heavy coating of special blue paint. The gear, pinion, shaft field and screws are all nickel plated, dull finish.

Ordering Information

Code No. of Generator	No. of Bars	Height	Size Overall, Inches Length	Width
15	3	5 3/4	6 1/2	4
53	5	5 3/4	8	4
75	6	5 3/4	9	4

Note: Pulsating current generators can be furnished on request.

Parts Used in All No. 15, 53 and 75 Generators

Part No.	Description	Quantity Used	Part No.	Description	Quantity Used
42687	Spring Assembly	1	12172	End Bracket Assembly	1
3272	Stop Collar	1	12175	End Bracket Assembly	1
3266	Spring	1	5019	Washer	2
4453	Escutcheon	1	6130	Screw (No. 15 and 53 Only)	1
15911	Crank Assembly	1			
3265	Collar Assembly	1			
3267	Gear Assembly	1			
3273	Pinion	1			

Major Parts

Code No. of Generator	Magnet	Armature Assembly	Mounting Bracket	Shaft Assembly	Shaft Ins.
15	3276 (3)	12973	51527	7732
53	13459 (2)	12974	13461	51515	7732
	13462 (2)				
	29992 (1)				
75	57856 (3)	53965	39918	51525	7732
	57857 (3)				

No. 51527 Shaft Assembly consists of one No. 51512 sleeve, one No. 51513 Pin and one No. 51526 Shaft.

No. 51515 Shaft Assembly consists of one No. 51512 sleeve, one No. 51513 Pin and one No. 51514 Shaft.

No. 51525 Shaft Assembly consists of one No. 51512 sleeve, one No. 51513 Pin and one No. 51524 Shaft.

Parts for four bar Generators (No. 22, etc.) will be found in list of parts for either No. 15 or 53 Generators.

No. 104 Generator

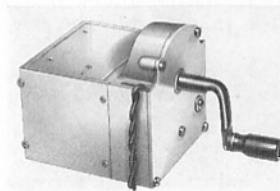

The new design, materials and type of construction embodied in this rugged, compact generator bring a great reduction in both size and weight. Yet its output is equal to the old style large generators. It has a "no-load" voltage of 100 volts, and will ring fifty 2500 ohm bells

through 1500 ohms resistance, and five 2500 ohm bells through 19,000 ohms resistance. The entire generator is housed in a dust-proof aluminum case which seals it and the oilless bearings and gears from dust and moisture. It operates smoothly and is ruggedly designed to give maximum life.

No. 104 Generator is 3 1/4 inches high, 3 1/4 inches long (with crank, length is 5 1/2 inches) and 2 7/8 inches wide. Shipping weight is 3 1/2 lbs.

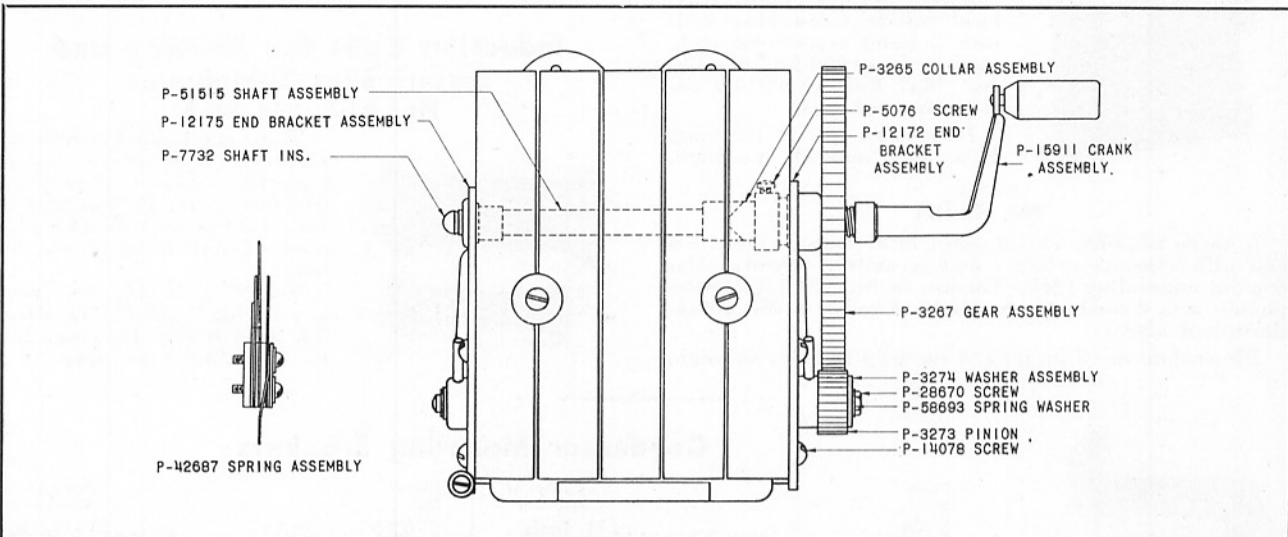

No. 53, 5 Bar Generator

KELLOGG HOOKSWITCHES

Kellogg Hookswitches are mounted on steel frames. The springs are of heavy nickel silver and assembled with a steel reinforcing spring insuring positive contact. The hook is easily removed by simply pushing the spring forward. Phenol fibre insulations are used. Kellogg hookswitches are simple in construction, yet reliable in operation.

Kellogg hookswitches are divided into two main classes: for regular hand receivers and for handsets. Each of these two classes is available: with escutcheon plate for mounting on wood sets, with bracket for mounting on the base of steel sets or with neither escutcheon plate nor bracket for mounting directly on steel sets.

With Escutcheon Plate — For Hand Receivers

Battery saver latch shown on Nos. 103, 156 and 163 hookswitches furnished only when specified.

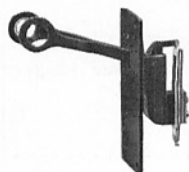

No. 103

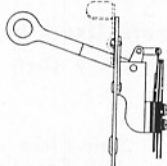

No. 156

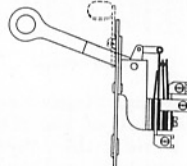

No. 163

With Bracket — For Hand Receivers



No. 113

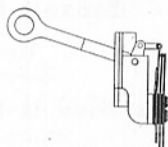

No. 145



No. 150

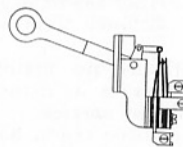

No. 151

With Escutcheon Plate — For Handsets

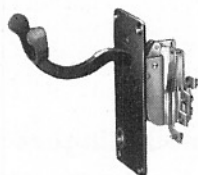

No. 165

Same as No. 163 shown above, except that switch hook lever No. 56280 for handsets is used instead of No. 46811 for regular receivers.

With Bracket — For Handsets

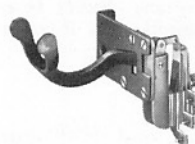

No. 157

With Neither Bracket Nor Escutcheon Plate — For Handsets

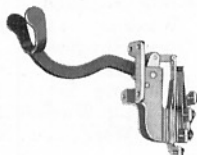

No. 168

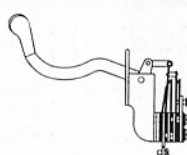

Nos. 158 and 170

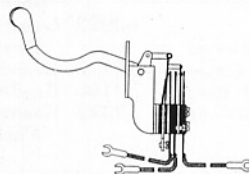

No. 164

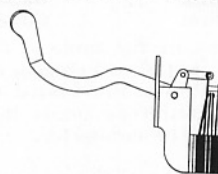

No. 169

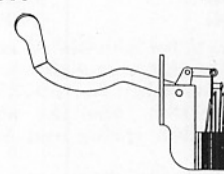

No. 109 Hookswitch

Designed for head band receivers used with No. 2945 telephones. Uses switch hook lever No. 31011, shown below.

No. 159 Hookswitch

Designed for receiver No. 81-A, used with No. 4883 telephones. Uses switch hook lever No. 27871, shown below.

Switch Hook Levers



No. 46811
For regular receivers.



No. 56280
For handsets.

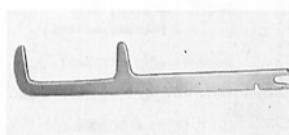

No. 31011
For headband receivers,
used with No. 2945
telephones, etc.



No. 27871
For No. 81-A receiver
used with No. 4883
telephones.

Telephone Section

KELLOGG RINGERS

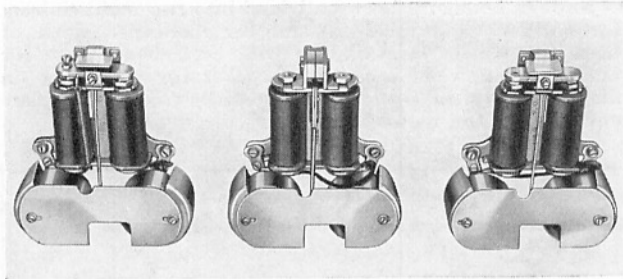

Biased

Non-Biased

Harmonic

The new, small, efficient, one-piece Kellogg ringers are mounted as a complete unit on the baseplate of the telephone which acts as a sounding board. Besides this, there have been developed gongs of new design and materials and a resonance chamber which permits concentration and utilization of all sound waves, directed through holes in the base.

The result is a pleasing tone, whether far or near, and a penetration of sound at greater distance than with the older type of ringer.

Kellogg ringers require practically no maintenance. Armatures hold their positive, accurate adjustment and almost never require setting while in service.

Kellogg ringers are available in three types, harmonic, biased and non-biased. The harmonic type operates on a number of frequencies as is shown at right. The biased type is equipped with a spring to prevent tapping of the bell due to stray impulses.

The ringer is easily mounted and is interchangeable in all the wall and desk type Masterphones. Note: Harmonic and biased type ringers are supplied with flexible leads terminating in spade tips.

Non-Biased Ringers

Non-Biased ringers are used in 930 and 950 type Magneto Masterphones when ringers are required.

Code No.	Resistance	Part No. of Coil Assembly
110-A	1000 Ohm	59147
110-D	1600 Ohm	60587
110-G	2900 Ohm	60588

Parts for non-biased ringers are the same as for biased ringers shown at right except that biased ringers use armature assembly No. 59185 while the non-biased type uses No. 59189. Also the non-biased type omits the use of No. 61368 spring and No. 61949 connector.

Harmonic Ringers

Code No.	Frequency in Cycles	Part No. of Coil Assembly	Code No.	Frequency in Cycles	Part No. of Coil Assembly
112-A-1	33 1/3	58942	113-A-3	54	58942
112-A-2	50	58942	113-A-4	66	58942
112-A-3	66 2/3	58942	114-A-1	25	58943
112-A-4	16 2/3	58943	115-A-1	20	58943
113-A-1	30	58942	115-A-2	60	58942
113-A-2	42	58942			

Parts Used in Harmonic Ringers Only

For other piece parts used in all one-piece ringers see table below.

Part No.	Description	Quantity Used
58879	Pole Piece	2
61231	Nut for Coil Assembly	4
58942 or 58943	Coil Assembly — See Table Above	1

Biased Ringers

Code No.	Type	Part No. of Coil Assembly
116-G	Biased	60588

Parts Used in Biased Ringers

Part No.	Description	Quantity Used
59185	Armature Assembly	1
59167	Armature Support Assembly	1
59172	Magnet Extension	1
59441	Adjusting Screw and Nut Assembly	2
59140	Screw and Nut Assembly	1
58941	Nut for Coil Assembly	1
61367	Magnet and Heel Plate Assembly	1
61368	Spring	1
61949	Connector	1

Parts Used in All Small Ringers

Part No.	Description	Quantity Used	Part No.	Description	Quantity Used
62021	Gong and Support Assembly	1	62024	Gong Supp. Scr.	4
62022	Gong and Support Assembly	1	58944	Gong Support Washer	4
59320	Resonator Plate	1	24801	Gong Support Washer	4
59180	Resonator Screw	2	58869	Mounting Screw	2
59312	Resonator Washer	2	58945	Mount'g Washer	2
			59447	Lead Wire	2

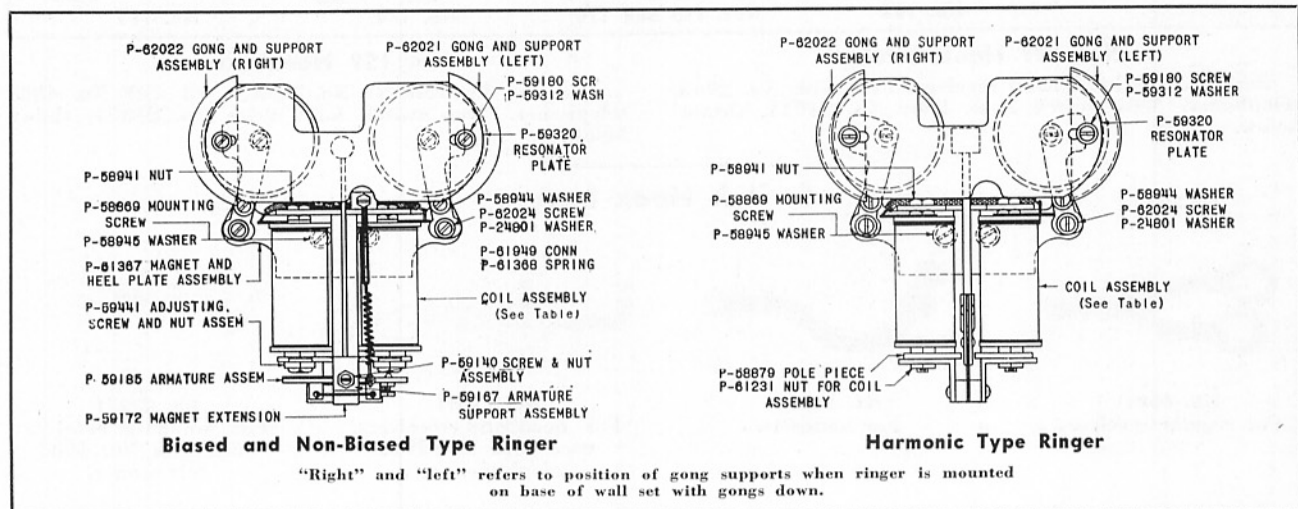

KELLOGG RINGERS

Gong and Support Assembly, One-Piece Ringers Left, Assembly No. 62021; Right, Assembly No. 62022

LEFT Part No.	RIGHT Part No.	Description	Quantity Used
58947	58947	Gong	1
62018	62019	Resonator Cup, Support and Stud Assembly	1
61028	61028	Washer	1
61030	61030	Spring	1
59076	59076	Screw	1

Gong and Resonator Parts for Ringers with Gongs that Mount Separately

Part No.	Description	Quantity Used	Part No.	Description	Quantity Used
58947	Gong	1	61028	Washer	1
58892	Gong Support Assembly	1	61030	Spring	1
			59076	Screw	1

Two No. 59078 screws, two No. 58944 spring washers and one No. 54801 flat washer are used for mounting each gong support.

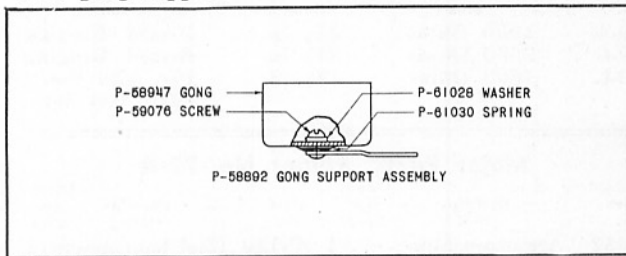
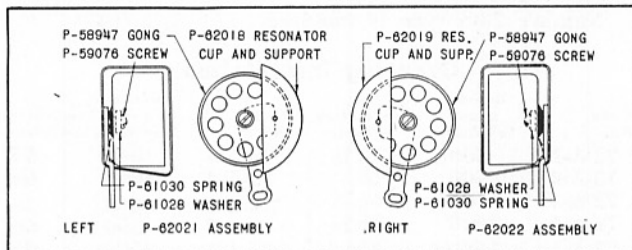

The diagram above shows the gong and support assembly for One-Piece Ringers, standard in Kellogg 925 and 900 type desk Masterphones, 9900 and 9917 type wall Masterphones and 700 type desk set boxes.

The diagram above shows gongs and resonators for ringers with gongs mounted separately on the telephone base plate. This type of ringer has been superseded by the One-Piece type shown at left.

Large Type Ringers

Kellogg large type ringers are constructed throughout of the best materials and are so designed that they will not magnetize and stick. They can be furnished in either the adjustable or non-adjustable type and are fitted with high-grade brass gongs which are sand blasted and heavily black enameled. The long-type, high-impedance coils have cores of soft, annealed Norway Iron. The spools are carefully insulated and wound with highest grade

copper wire. Connectors are attached to spools eliminating breakage of coil wires. The permanent magnet is of high quality magnet steel. The armature has a thin strip of special metal attached to it which prevents sticking. The taper rod is of proper length to give sure, instant signaling. Adjustable gong posts keep the center type gongs in the correct position. These ringers are used in steel and wood sets.

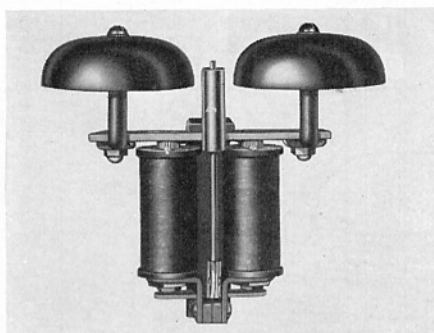

Common Battery, Harmonic Type

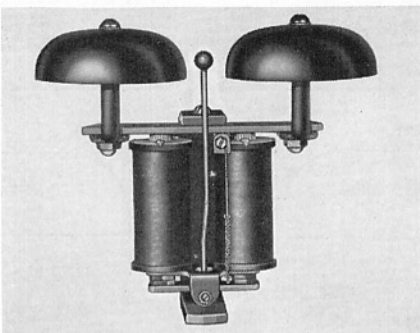

Common Battery, Biased Type

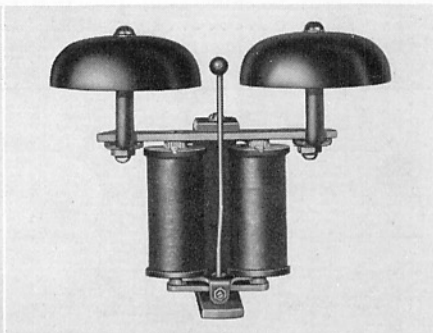

Magneto Type

Magneto Type — Non-Adjustable

The Kellogg No. 78 type ringer has a non-adjustable armature and is standard for magneto telephones. This ringer is built for maximum efficiency and the armature adjustment cannot be changed. This adjustment insures ringer's response to the weakest currents, yet it will not freeze or stick. Can mount on wood of any thickness up to 3/4 in.

Ordering Information

Code Number	Resistance	Size of Gong	Description
78-A	1000 Ohms	2 1/2 in.	Straight Line, Bridging
78-D	1600 Ohms	2 1/2 in.	Straight Line, Bridging
78-G	2500 Ohms	2 1/2 in.	Straight Line, Bridging

Major Parts Used in Ringers 78-A, 78-D and 78-G

Part No.	Description	Quantity Used
12160	Armature Support Assembly	1
12154	Magnet	1
50411	Heel Iron Assembly	1
12157	Armature	1
30488	Gong	2
51098	Coil Assembly (78-A Only)	2
51156	Coil Assembly (78-D Only)	2
51140	Coil Assembly (78-G Only)	2

Telephone Section

KELLOGG RINGERS

Common Battery Type — Adjustable

The Kellogg No. 79 type ringer, being of the adjustable type is standard for common battery service in steel and wood sets. This ringer is equipped with special biased ringing, and is of the same general construction as the No. 78 type except for the adjustable armature air gap. Can be mounted on wood of any thickness up to 3/4 inch. Illustrated on page No. 43.

Ordering Information

Code No.	Resistance	Size of Gong	Description
79-A	1000 Ohms	2 1/2 in.	Biased Ringing
79-C	2500 Ohms	2 1/2 in.	Biased Ringing
18-C	1600 Ohms	1 3/4 in.	Use with No. 1016 Test Set

Major Parts, Ringer No. 79-A

Part No.	Description	Quantity Used	Part No.	Description	Quantity Used
2452	Armature Support Assembly . . .	1	45120	Heel Iron Assem. . .	1
2445	Magnet	1	51198	Coil Assembly . . .	2
11612	Armature Assem. . .	1	1874	Spring	1
			30488	Gong	2

Major Parts, Ringer No. 79-G

Part No.	Description	Quantity Used	Part No.	Description	Quantity Used
2452	Armature Support Assembly . . .	1	45120	Heel Iron Assem. . .	1
2445	Magnet	1	51081	Coil Assembly . . .	2
11612	Armature Assem. . .	1	1874	Spring	1
			30488	Gong	2

Major Parts, Ringer No. 18-C

Part No.	Description	Quantity Used	Part No.	Description	Quantity Used
2452	Armature Support Assembly . . .	1	45124	Heel Iron Assem. . .	1
2445	Magnet	1	51066	Coil Assembly . . .	2
34462	Armature Assem. . .	1	2894	Gong	2

Harmonic Ringers

Kellogg Harmonic Ringers — that most important item in common battery party line telephone service — are in a class by themselves, tried and tested and proved through many years of service under all conditions.

They are equipped with a positive gong adjustment. Once set, the adjustment remains so indefinitely. The adjustment is made at the base of the gong post with the aid of a screw driver and a special wrench furnished with the ringer. Gongs are 2 1/2 inches in diameter. Illustrated on page No. 43.

Number 73-A type is standard.

Ordering Information

Code No.	Resistance in Ohms	Frequency in Cycles	Code No.	Resistance in Ohms	Frequency in Cycles
72-A-1	500	33 1/3	73-A-3	1000	54
72-A-2	500	50	73-A-4	1000	66
72-A-3	500	66 2/3	74-A-1	2500	20
72-A-4	2500	16 2/3	74-A-2	500	60
73-A-1	1000	30	101-A-1	2500	25
73-A-2	1000	42			

Major Parts

Code No.	Armature Assembly	Coil Assembly (2 Req.)	Gong Assembly (2 Req.)	Heel Iron Assembly	Magnet
72-A-1	6498	61328	30488	42291	6705
72-A-2	6718	61328	30488	42291	49194
72-A-3	6719	61329	30488	42291	49194
72-A-4	6720	51081	30488	42291	6705
73-A-1	15193	51198	30488	42291	6705
73-A-2	15194	51198	30488	42291	6705
73-A-3	15195	51198	30488	42291	6705
73-A-4	15196	51198	30488	42291	49194
74-A-1	15191	51081	30488	42291	6705
74-A-2	15192	61329	30488	42291	49194
101-A-1	43475	51081	30488	42291	6705

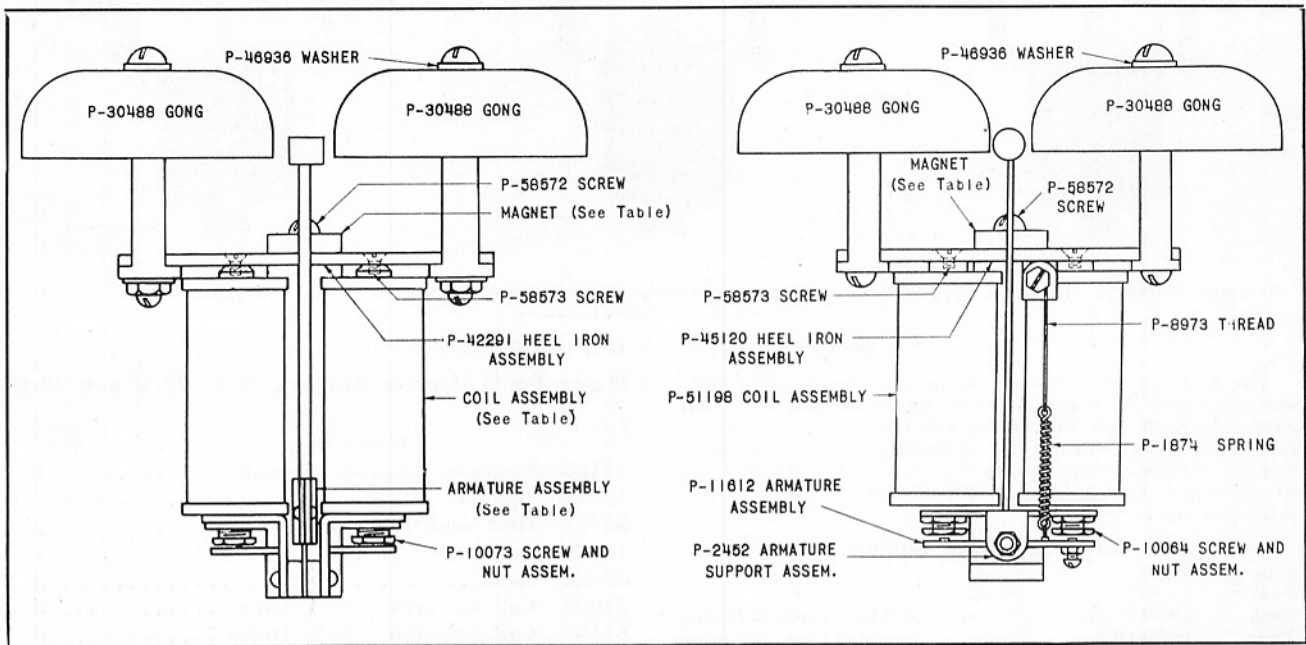

Harmonic Type

Common Battery Type, 79-A and 79-G

KELLOGG RECEIVERS

Masterphone Capsule Type Receiver

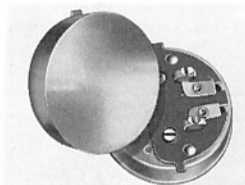

Front and Back Views of No. P55919 Receiver

The No. 55919 Masterphone handset receiver is a compact, self-contained unit which is easily removable. It has no cord connections, but as in the transmitter, two heavy bronze clips make the electrical connections. Locating lugs slide easily into the guide slots in the housing. The Bakelite cap grips the diaphragm firmly and evenly. Both receiver and transmitter caps

screw directly into the housing. No metal retaining rings are necessary. The receiver is of the standard bi-polar type using a cobalt magnet which has more magnetic saturation and longer life. It is in perfect electrical balance.

The diaphragm is cadmium plated and carries Kellogg part No. 58015. Diameter of diaphragm is $2\frac{3}{8}$ in.

Subscribers' Hand Receivers



Standard hand telephone receiver with long magnets of the bi-polar type, with heavy brass retaining cup, 36-inch moisture-proof receiver cord with heavy tinsel conductors and high-grade insulation.

The Bakelite shell is highly polished and the cord hole in the end of the case is rounded out which prevents excessive wear on the cord. The ear cap securely holds the diaphragm and receiver in the shell and is shaped to perfectly fit the orifice of the ear and has no objectionable lettering around the edge.

The shell and cap are of a standard size so that many other makes of receivers will fit the shell perfectly.

The cord terminals are so designed that either spade or spike tip cord terminals can be used. The cord is regularly supplied with spade tips on both ends.

Ordering Information

Code No.	D. C. Resistance	Description
F-41-A	62 ohms	Standard
F-41-B	650 ohms	High Impedance

Major Parts

F-41-A Part No.	F-41-B Part No.	Description	Quantity Used
32269	32269	Shell Assembly—Shell & Cap.	1
F-644-TR	F-644-TR	Cord	1
45210	55884	Coil Assembly	1
45211	55885	Coil Assembly	1
58015	58015	Diaphragm (Diam., $2\frac{3}{8}$ in.)	1

Railroad Dispatching Receivers No. 80 Type

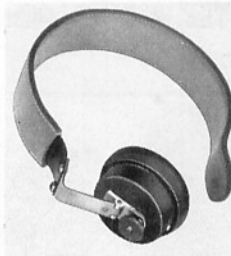

Small watch case type receiver with a weighted brass shell. A long-life, cobalt magnet with more magnetic saturation makes this a very efficient receiver. It may be used with No. 2 headband shown in the illustration.

Code No.	Description	Resistance
80-A	Receiver	60 ohms
80-B	Receiver	600 ohms
2	Headband, leather covered. (Must be ordered separately.)	

Additional leather covering for headband can be ordered separately.

Major Parts

80-A Receiver	80-B Receiver	Description	Quantity Used
56131	56131	Permanent Magnet	1
44358	44358	Bakelite Cap	1
55240	56240	Coil Assembly	1
55241	56241	Coil Assembly	1
58016	58016	Diaphragm (Diam., $1\frac{1}{2}$ in.)	1
55480	55480	Thumb Nut	1
57304	57304	Screw (Terminal)	2

No. 81 Type

Same as No. 80 type except provided with a ring for hanging on hook.



Code No.	Resistance
81-A	60 ohms

Major Parts, 81-A Receiver

Part No.	Description	Quantity Used
56131	Permanent Magnet	1
44358	Bakelite Cap	1
58016	Diaphragm (Diameter, $1\frac{1}{2}$ in.)	1
55240	Coil Assembly	1
55241	Coil Assembly	1
55480	Thumb Nut	1
57304	Screw (Terminal)	2
55479	Eye	1

Transmitter Arms for Telephones

Kellogg adjustable transmitter arms are of pressed brass and steel construction, and are free from heavy or brittle castings. They adjust readily and easily, and are so designed as to keep their adjustment. They are attractively finished in black enamel and all wiring is concealed.



No. 50

This arm consists of the base of No. 42 and the transmitter mounting of the No. 41 arm. This is the standard arm for magneto telephones. Depth from transmitter to back is $2\frac{3}{8}$ inches.



No. 41

The transmitter back of this arm is of punched brass, black enameled and balance of the arm is of pressed steel, black enameled, adjustable to 15 degrees above and 15 degrees below horizontal. This arm is used on wood, residence type sets and requires a 2-inch opening in woodwork to mount; concealed cord; net weight, 5 ounces.

No. 39

The transmitter back of this arm is of punched brass, black enameled, the balance punched steel. This arm is used on steel residence sets; $\frac{3}{4}$ inch long; adjustable to 15 degrees above and 15 degrees below horizontal; concealed cord.

Telephone Section

KELLOGG TRANSMITTERS

One-Piece Bakelite Transmitter Front and Mouthpiece With The Kellogg NON-POSITIONAL Transmitter

Type 121

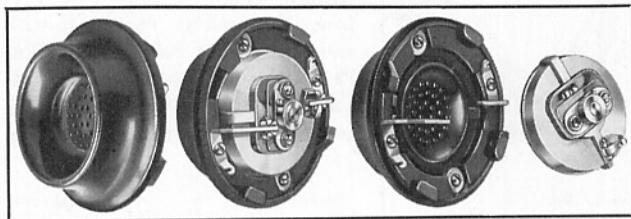

This one-piece, molded Bakelite transmitter front and mouthpiece unit fits all types of Kellogg wall sets and desk stands using transmitter arms. The same assembly also fits all Western Electric wall sets and desk stands and it is easily adapted to some other makes by using Piece No. 46279 black enameled back described in next column.

Molded of rich, black Bakelite with a wide mouthpiece opening, this one-piece unit is practically indestructible. It takes the famous NON-POSITIONAL transmitter and makes this one unit standard for all sets. The locating lugs on the transmitter case slip into corresponding guide slots in the Bakelite housing. The electrical connections are made by two heavy metal blades engaging the bronze contact clips. These blades are formed with one end providing a slotted terminal to which the transmitter cord may be soldered. Each blade is positioned between two Bakelite shoulders and anchored by a single screw.

No. 121-C

Bakelite front and mouthpiece unit with NON-POSITIONAL transmitter, for common battery or local battery operation.

No. 121-L

Bakelite front and mouthpiece unit with NON-POSITIONAL transmitter, for local battery operation only, such as railways, oil field lines, etc., where extra transmission is more important than battery consumption.

Parts Used in No. 121-C Transmitter Front

Part No.	Description	Quantity Used	Part No.	Description	Quantity Used
62178	Bakelite Front	1	60419	Washer	2
60416	Terminal	2	5191	Mounting Screw	4
55806	Screw		57340	Transmitter Assembly	1
59033	(Terminal) Screw	2			

Bakelite Telephone Mouthpieces

No. 29779



Pc. No. 29779 telephone mouthpieces are made of Bakelite which is unbreakable in ordinary service. These mouthpieces retain their glossy finish and are not affected by heat, chemicals, moisture, etc.

No. 34419

Special for Stromberg-Carlson telephones, Monarch, American, Electric, etc.

Kellogg can furnish composition mouthpieces for those desiring them. Also Bakelite mouthpieces to fit other makes of telephones.

Type 117

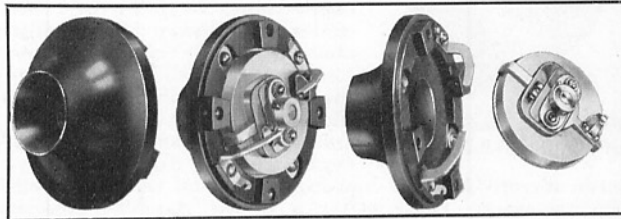

Same as type 121 Bakelite Transmitter Front and Mouthpiece Unit except has a smaller mouthpiece opening.

No. 117-C

Bakelite front and mouthpiece unit with NON-POSITIONAL transmitter for common battery or local battery operation.

No. 117-L

Bakelite front and mouthpiece unit with NON-POSITIONAL transmitter for local battery operation only, such as railways, oil field lines, etc., where extra transmission is more important than battery consumption.

No. 46279

Black enameled metal back for adapting the 117 transmitter to some makes of telephones other than Kellogg or Western Electric.

Parts Used in 117-C Transmitter Front

Same as for No. 121-C except uses No. 60418 Bakelite Front and our No. 2629 Mounting Screws.

Masterphone Transmitter

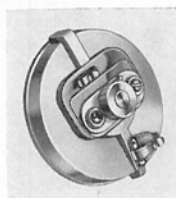

No. 57340

This transmitter provides the Masterphone with the finest type of transmission available in handset telephones. It is a self-contained, capsule type, NON-POSITIONAL transmitter, designed as a unit with no cord connections. It is easily installed without the use of tools. Two different sized locating lugs correspond to guide slots in wall of housing which insures the transmitter of always being in correct position. The heavy bronze clips make positive electrical contact by gripping bar conductors firmly on both sides.

Fits in Masterphone handpieces as well as Types 117 and 121 transmitter fronts.

No. 115 Transmitter

Same as No. 57340 but arranged to fit Nos. 19 and 21 type handsets.

Uses No. 58288 terminals with two No. 58290 screws.

No. 46279 Transmitter Back

Kellogg standard metal transmitter back furnished unless otherwise specified. Handsomely finished in black enamel. Will attach to any make telephone arm requiring two screws for mounting transmitter.

INDEX

A	Page
Arms, Extension	30
Arms, Transmitter	45
Automatic Telephones	10 to 25
B	
Backs, Transmitter	46
Bakelite Desk Set Boxes	23
Bakelite Handsets	23, 34
Bakelite Key Boxes	35
Bakelite Masterphones	10 to 28
Bakelite Mouthpieces	46
Bakelite Telephones	
Common Battery	10 to 22
Magneto	10 to 28
Bakelite Transmitter Fronts	46
Bands, Head	45
Battery Saver	36
Bells, Loudringing	33
Bells, Magneto Extension	33
Biased Ringers	42, 43
Binding Posts	36
Blanks, Dial	37
Blocks, Connector	36
Boxes, Desk Set	
Common Battery	23, 24
Magneto	27, 28, 31
Boxes, Key	35
Brackets, Condenser Mounting	39
Bracket Telephones	30
C	
Cable (see Supply Section)	
Capsule Type Receivers	45
Capsule Type Transmitters	46
Circuit, Triad	7
Coils, Induction	39
Common Battery Ringers	44
Common Battery Desk Set	
Boxes	23, 24
Common Battery Master- phones	10 to 22
Common Battery Tele- phones	10 to 26
Combination Masterphones	10 to 28
Compact Type Wall Telephones	29
Composite Wall Telephones	31
Condensers	33
Condenser Mounting Brackets	39
Connecting Racks	39
Connector Blocks	36
Conversion Kits	37
Coils, Induction	39
Cover Plates	37
Customer Information	2
D	
Desk Set Boxes	
Bakelite	23
Common Battery	23, 24
Magneto	27, 28
Steel	24
Wood	27, 28
Desk Stands	
Common Battery	24
Magneto	28
Desk Type Masterphones	
Common Battery	10 to 22
Magneto	10 to 28
Dial Blanks	37
Dial Type Masterphones	10 to 21
Dial Type Telephones	10 to 25
Dry Cells (See Supply Section)	

E	Page
Extension Arms	30
Extension Bells, Magneto	33
F	
Foot Switch	30
Flush Mounting Plugs and Jacks	35
Front Mounting Wall Master- phones	19, 27
Fronts, Transmitter	46
G	
Generators	40
Generator Boxes	30
Gongs, Ringer	42, 43, 44
H	
Handsets, Bakelite	23, 34
Handsets, Metal	34
Handset Telephones	
Common Battery	10 to 26
Magneto	10 to 29
Hand Receivers	45
Harmonic Ringers	42, 44
Head Bands	45
Heavy Duty Telephones	30, 31
Hookswitches	41
Howlers	31
I	
Induction Coils	39
Information, Customer	2
Insulated Telephones	30, 31
J	
Jacks, Wall Outlet	35
K	
Key Boxes	35
Kits, Conversion	37
Koiled Kords (See Supply Section)	
L	
Levers, Switch Hook	41
Lightweight Portable Telephones	32
Lineman's Test Sets	32
Loudringing Bells	33
M	
Magneto Desk Set Boxes	27, 28
Magneto Desk Stands	28
Magneto Extension Bells	33
Magneto Masterphones	10 to 29
Magneto Non-Adjustable Ringers	43
Magneto Telephones	10 to 33
Manual Type Telephones	
Common Battery	10 to 26
Magneto	10 to 33
Masterphones	6 to 29
Automatic	10 to 21
Bakelite	
Common Battery	10 to 22
Magneto	10 to 28
Combination	10 to 28
Common Battery	10 to 22
Desk Type	
Common Battery	10 to 22
Magneto	10 to 28
Dial Type	10 to 21
Front Mounting	19, 27
Handsets	23, 34
Heavy Duty	31
Magneto	10 to 29

M (Continued)	Page
Masterphones (Continued)	
Manual Type	
Common Battery	10 to 22
Magneto	10 to 29
Side-Mounting	18, 19, 20, 27
Wall Type	
Common Battery	12 to 20
Magneto	18 to 29
Masterphone Handsets	23, 34
Masterphone Receivers	45
Masterphone Transmitters	46
Metal Handsets	34
Mounting Brackets, Condenser	39
Mounting Brackets, Extension	
Arm	30
Mouthpieces, Telephone	46
N	
Non-Adjustable Ringers	43
Non-Biased Ringers	42
Non-Positional Trans- mitters	3, 4, 5, 46
Number Plates, Transmitter Type	36
O	
Oil Field Telephones	31
One-Piece Bakelite Transmitter Fronts	46
One-Piece Ringers	42, 43
Outdoor Telephones	26, 33
P	
Pay Stations (See Supply Section)	
Pedestal Type Telephones	
Common Battery	24
Magneto	28
Piece Parts	
Compact Type Wall Telephones	29
Desk Set Boxes	
Common Battery	23, 24
Magneto	27, 28
Desk Stands	
Common Battery	24
Magneto	28
Front Mounting Wall Master- phones	19, 27
Generators	40
Handsets	23, 34
Hookswitches	41
Insulated Telephones	30, 31
Key Boxes	35
Magneto Telephones	10 to 33
Manual Telephones	10 to 33
Masterphones	
Common Battery	10 to 22
Magneto	10 to 29
Oil Field Telephones	31
Outdoor Telephones	26, 33
Pedestal Type Telephones	24, 28
Portable Telephones	32
Railway Telephones	31
Receivers	45
Ringers	42, 43, 44
Side-Mounting Master- phones	18, 19, 20, 27
Telephones	
Common Battery	10 to 26
Magneto	10 to 28
Transmitters	46
Wall Telephones	
Common Battery	12 to 25
Magneto	18 to 29
Weatherproof Telephones	26, 33

Telephone Section

INDEX

P (Continued)		Page
Plugs and Jacks		35
Portable Telephones		32
Posts, Binding		36
R		
Racks, Connecting		39
Railway Dispatching Receivers ..		45
Railway Telephones		30
Receivers		45
Receiver Hooks		41
Ringers		42, 43, 44
S		
Savers, Battery		36
Sets, Test		32
Side-Mounting Master- phones		18, 19, 20, 27
Side-Mounting Masterphones, Magneto		27
Special Telephones		30, 31, 32
Stands, Desk		24, 28
Steel Desk Set Boxes		24
Steel Telephones Common Battery		18 to 26
Magneto		18 to 33
Subscribers' Hand Receivers		45
Surface Mounting Plugs and Jacks ..		35
Switch, Foot		30
Switch Hooks		41
Switch Hook Levers		41
T		
Telephone Extension Arms		30
Telephone Mouthpieces		46
Telephone Tools		36

T (Continued)		Page
Telephones		
Automatic Type		10 to 25
Bakelite Common Battery		10 to 22
Magneto		10 to 28
Bracket Type		30
Common Battery		10 to 26
Combination Type		10 to 28
Compact Type		29
Composite		31
Desk Stands Common Battery		24
Magneto		28
Desk Type Common Battery		10 to 24
Magneto		10 to 28
Dial Type		10 to 25
Front Mounting		19, 27
Handset Type Common Battery		10 to 26
Magneto		10 to 29
Heavy Duty		31
Insulated		30, 31
Linemen's		32
Magneto		10 to 33
Manual Common Battery		10 to 26
Magneto		10 to 33
Masterphones Common Battery		10 to 26
Magneto		10 to 29
Oil Field		31
Outdoor		26, 33
Pedestal		24, 28
Portable		32

T (Continued)		Page
Railway		31
Side-Mounting		18 to 20
Side-Mounting Magneto		27
Special Sets		30, 31, 32
Steel Sets		18 to 33
Wall Sets Common Battery		12 to 25
Magneto		18 to 29
Weatherproof Common Battery		26
Magneto		33
Test Sets		32
Tools, Telephone		36
Triad Circuit		7
Transmitters		46
Transmitter Arms		45
Transmitter Backs		46
Transmitter Fronts		46
Transmitters, Non-Posi- tional		3, 4, 5, 46
Transmitter Type Number Plates ..		36
W		
Wall Masterphones Common Battery		12 to 20
Magneto		18 to 29
Wall Telephones Common Battery		12 to 25
Magneto		18 to 29
Wall Outlet Plugs and Jacks		35
Weatherproof Loudringing Bells ..		33
Weatherproof Telephones Common Battery		26
Magneto		33
Wood Desk Set Boxes		27, 28

Numerical Listing of Codes for Kellogg Telephones

Type or Code No.	Page No.	Type or Code No.	Page No.	Type or Code No.	Page No.
1.....Foot Switch	30	900	14, 15, 28	4816	29
12.....Keybox	35	925	10, 11, 23	4820	29
13.....Keybox	35	930	10, 11, 27	4880	29
19-L.....Handset	34	950	14, 15, 27	4883	33
22-C.....Handset	34	951	31	4888	33
27-C.....Handset	23	952	31	4900	26
32-C.....Handset	34	1016	32	4901	26
37.....Bell	33	1025	32	4902	26
39-C.....Handset	34	1983	31	4903	26
40-C.....Handset	34	2328	28	5809	29
43-C.....Handset	34	2361	28	5812	29
44-C.....Handset	34	2370	28	5816	29
65.....Bell	33	2362	28	5845	31
90-A	31	2371	28	5859	29
301	24, 28	2413	30	5880	29
305	24	2414	30	6884	31
601	30	2515	31	6886	31
602	24	2528	27	9710	19
605	24	2561	27	9720	18, 19, 20
610	24	2562	27	9735	18, 19, 20
700.....(Tel.)	22, 28	2869	31	9736	18, 19, 20
700.....(D. S. Box)	23	2945	30	9740	18, 19, 20
705	23	3001	32	9741	18, 19, 20
710	22	3025	32	9817	25
725	21	4415	31	9830	18, 19, 20
730	21	4421	30	9837	19, 27
817	25	4809	29	9900	16, 17
		4812	29	9917	12, 13

Kellogg

TELEPHONE & SWITCHBOARD

Cords



GENERAL CATALOG NO. 10

CABLE

Switchboard Cable	17
Power Cable	18

CORDS

Breastplate Transmitter Cords.....	12
Desk Stand Cords.....	8, 9, 10
Desk Stand Transmitter Cords.....	10
Handset Cords	6, 7, 8
Kellogg Coiled Cords.....	20
Operator's Cords	12, 13
Receiver Cords	11
Switchboard Cords	14, 15
Switchboard Suspended Type Cords.....	10

CORD ACCESSORIES

Cord Fasteners	16
Cord Hooks	16

Cord Tips	16
Cord Weights	16
Kellogg Cords Listed by Types.....	4
Kellogg Equivalents of Other Cords.....	5
Lacing Twine	17
Rubber Plug Cushions.....	16
Specifications and Cord Drawings.....	6 to 15
Tools	15

WIRE

Flameproof Jumper Wire.....	19
Flexible, Insulated Stranded Wire.....	18
Generator Wire	19
Switchboard Wire	18
Telephone Cable Wire.....	18

COMPLETE INDEX.....	20
---------------------	----

KELLOGG SWITCHBOARD AND SUPPLY COMPANY

Factory and General Offices: 6650 S. CICERO AVE., CHICAGO, ILL., U. S. A.

Branch Offices: 308 W. Sixth St., Kansas City, Mo. -- 246 First St., San Francisco, Calif.

Why Kellogg Cords Are Your Best Buy!

Making Kellogg Cords

These views give some idea of the gigantic size, enormous facilities, modern machines, and the excellent working conditions of the Kellogg cord department. These things contribute to economical production and make for the greatest cord values.

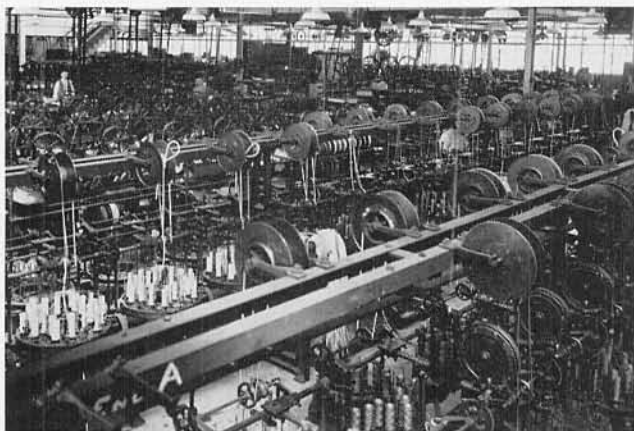

EXPERIENCE COUNTS: Vast floor space in the great new Kellogg factory is devoted to the manufacture of telephone and switchboard cords. Here is where machines, materials and experts collaborate in the production of these cords which have long been recognized as the finest in the industry. The average experience of Kellogg cord department operators covers more than 10 years each.

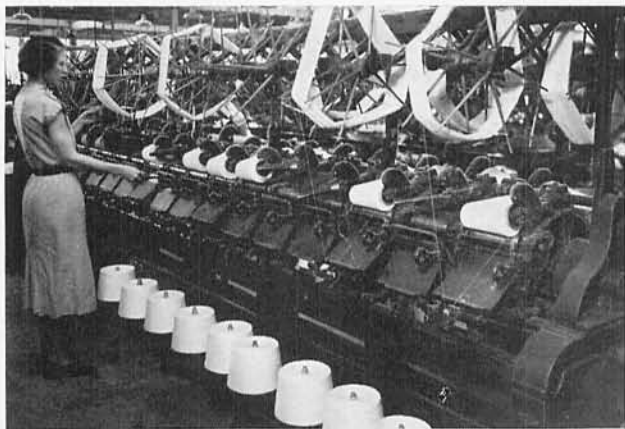

FROM SKEINS TO SPOOLS! Here is where cellulose acetate yarn and cotton are put on spools for use on the automatic braiding and cording machines. Hundreds and hundreds of these spools, containing miles and miles of thread, are needed to keep this great Kellogg Cord department supplied.

Year after year in thousands of exchanges everywhere, Kellogg cords are on the job. They are the standard in so many exchanges because most telephone men know that these good, long life cords eliminate subscriber complaints and keep operating costs down.

Kellogg's modern laboratory is constantly developing new and better materials and finding improved methods of manufacture and construction. These are the reasons why Kellogg cords are uniformly superior. They stand the hard test of everyday service far better and longer than do ordinary cords.

25% to 35% More Life!

The newer materials and modern methods used in the manufacture of Kellogg cords have increased their life by 25% to 35%! This means longer wear and lower cost per year of service.

Conductors of all Kellogg cords are made up of six strands of a high quality bronze tinsel. Each strand consists of two ribbons of this tinsel spirally wrapped over a long-fibre cotton center. The conductors are of a tough, elastic material having high conductivity and the ability to stand up under the most exacting requirements.

Over this strong, pliable conductor, two wraps of silk or cellulose acetate yarn are applied in opposite directions. The covering is then impregnated with a moisture-proof sealing compound of high dielectric strength. One of the advantages of this special compound is that it does not harden and become brittle. This moisture-proofed conductor is then covered with a closely woven, soft cotton braid and, in the case of instrument cords, is finished with an application of closely woven, mercerized cotton outer braid.

On finishing switchboard cords, an overall braid of selected glazed cotton is applied, and, for extra reinforcement at the plug end, this braid is doubled for a distance of twelve inches. Both instrument and switchboard cords employ braids that have been carefully chosen for their long wearing qualities and good appearance.



90 MILES A DAY! This is the kind of speed at which these machines insulate wire and tinsel for Kellogg telephone and switchboard cords, jumper wire, etc. Each machine of this group applies up to three coverings of cellulose acetate yarn or cotton to as many as six different conductors **AT THE SAME TIME.**

KELLOGG CORDS

Braiding . . . An Important Factor in Cord Endurance

The proper application of the braid is one of the most important factors in producing a cord that will stand up well in service.

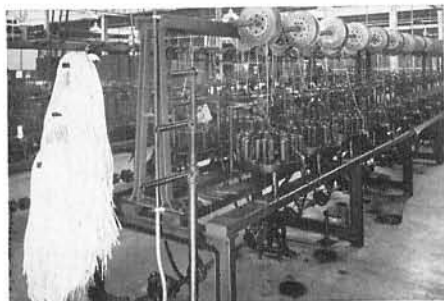

Some of the braiding machines in the cord department of the Kellogg plant.

A loosely woven braid wears quickly—a too tightly woven braid binds the tinsel. It takes exacting equipment and long experience to braid cords properly. But that isn't all! . . . the type of fibre used, the size and quality of thread, the setting of machines, etc., are details which must have exacting attention. All raw materials used by Kellogg are thoroughly tested in the laboratory before going into production. In this way, raw material is kept under observation to assure uniformity of quality and production. Every lot of tinsel is laboratory checked to see that it meets Kellogg specifications. Every cord is tested in the final inspection for shorts, conductivity, evenness of braid, strength of terminal attachment, etc. This watchfulness and precision in Kellogg production are your assurances of getting the finest quality in every cord.

Kellogg Cords are Better . . . Yet Cost No More!

The ever increasing volume of Kellogg cord sales is concrete evidence of the high regard telephone men have for them. Years of experience, skilled workmen, modern machines, a fully equipped laboratory and vast buying power mean tremendous production, unequalled quality and lowest prices.

You pay no premium for Kellogg cords, yet they make your dollar go farther.

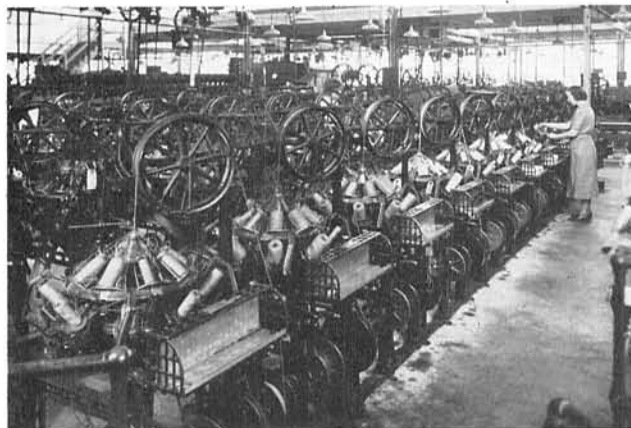

1200 TO 2000 FEET EVERY 8 HOURS! These are the speedy 16-spindle automatic braiding machines which handle all of the individual conductors for Kellogg telephone and switchboard cords, jumper wire, etc. Each machine in this giant battery can produce over one-third of a mile of braided conductors per day.

Use This Handy Cord Guide For All Your Cord Requirements

This cord guide makes it easy for you to order ALL your cords from one source. There is a Kellogg cord for every make and type of equipment. The most popularly used cords are listed in these pages. Others are available in stock for immediate shipment or can be quickly made up on order.

This book contains four general sections including a complete list of Kellogg cords, Kellogg equivalents of other manufacturer's cords, cord drawings with specifications and description of switchboard cable and various types of wire.

All are arranged for quick reference and are classified according to type and number of conductors. Both old and new code numbers are shown wherever changes have been made.

Complete Classified List of Kellogg Cords

Page 4 lists all standard Kellogg cords. Opposite each code number is the page number on which can be found a drawing and description of that cord.

Kellogg Equivalents of Other Cords

Page 5 contains a list of other manufacturer's cords with Kellogg equivalents. If you are using some other manufacturer's cords, simply look up the code number on page 5 and you will find the Kellogg cord which replaces it.

Specifications and Cord Drawings

Pages 6 to 15 contain cord drawings, listed by types with detailed descriptions.

Cable and Wire

Pages 17 to 19 contain description and specifications for switchboard cable, power cable, generator wire, telephone cable wire, switchboard wire and flame-proof jumper wire.

Koiled Kords, Rubber Plug Cushions, Etc.

On page 16 are shown cord hooks, weights, rubber plug cushions and terminals and on page 20 are shown Kellogg Koiled Kords.

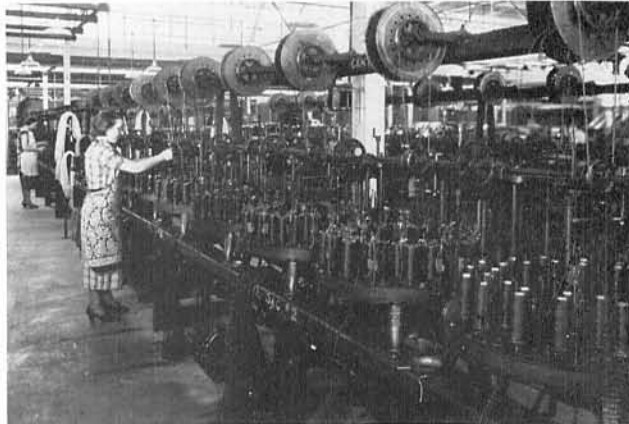

QUICKER THAN THE EYE! Here are the high speed "Maypole" type braiding machines which apply the overall braid to the cords. Each machine has 32 spindles traveling around the center and interweaving with each other. They flash around so fast that the eye can hardly follow. Conductors are fed through the center and come out as finished cords at the rate of 300 to 1000 per day for each operator.

Cord Section

KELLOGG CORDS LISTED BY TYPES

Here is a complete list of Kellogg cords conveniently arranged for quick reference. Each cord is shown by number and arranged according to the type and number of conductors. Where an old cord has been replaced, both

the old and new code numbers are shown. Opposite each code number is a reference to the page which contains the specifications and drawing of that cord.

Handset Cords

Kellogg Code No.	Replaces Kellogg Code No.	Specifications on Page	Kellogg Code No.	Replaces Kellogg Code No.	Specifications on Page
F-454-G		7	F-717-G		7
F-621-G		6	F-718-G		7
F-664-G		7	F-723-G		6
F-673-G		6	F-729-G		6
F-688-G		6	F-733-G		6
F-690-G		6	F-734-G		7
F-698-G		7	F-735-G		7
F-699-G		7	F-738-G		6
F-704-G		6	F-742-G		8

Desk Stand Cords

Two Conductor

Kellogg Code No.	Replaces Kellogg Code No.	Specifications on Page	Kellogg Code No.	Replaces Kellogg Code No.	Specifications on Page
665-D	100-D	8	667-D	581-D	8
F-665-D	F-100-D	8	F-740-D		8

Three Conductor

F-639-D	F-479-D	8	669-D	452-D	8
F-640-D	F-636-D	8	F-674-D		9
641-D	150-D	8	F-686-D		9
F-641-D	F-150-D	8	F-730-D		8
			F-739-D		9

Four Conductor

189-D		9	F-666-D	F-102-D	9
F-480-D		9	F-685-D		9
487-D		9	F-731-D		9
666-D	102-D	9			

Five Conductor

103-D		10	488-D		10
F-103-D		10	F-720-D		10

Six Conductor

F-679-D		10	F-680-D		10
---------	--	----	---------	--	----

Seven Conductor

Desk Stand Transmitter Cord

Kellogg Code No.	Replaces Kellogg Code No.	Specifications on Page
505-T		10

Receiver Cords

Kellogg Code No.	Replaces Kellogg Code No.	Specifications on Page	Kellogg Code No.	Replaces Kellogg Code No.	Specifications on Page
617-TR		11	646-TR	207-TR	11
644-RA		11	682-TR		11
F-644-RA		11	F-687-TR		11
644-TR	98-TR	11	F-716-TR		11
F-644-TR	F-98-TR	11	F-732-R		11
F-642-TR	197-TR	11			

Operator's Cords—For Head Receivers

Two Conductor

Kellogg Code No.	Replaces Kellogg Code No.	Specifications on Page	Kellogg Code No.	Replaces Kellogg Code No.	Specifications on Page
237-OR		12	708-OR	26-OR	12
466-OR		12	710-OR	110-OR	12
468-OR		12	719-OR		12
492-OR		12			

Operator's Cords — For Breastplate Transmitter Type Operator's Sets

Four Conductor

Kellogg Code No.	Replaces Kellogg Code No.	Specifications on Page	Kellogg Code No.	Replaces Kellogg Code No.	Specifications on Page
709-O	199-O	13	721-O	670-O	13
711-O	111-O	13	722-O	672-O	13
712-O	67-O	13	741-O		13
713-O	439-O	13	743-O		13

Breastplate Transmitter Cord

Two Conductor

Kellogg Code No.	Replaces Kellogg Code No.	Specifications on Page Number
726-T		12

Switchboard Cords

Tinsel

Two Conductor

Kellogg Code No.	Replaces Kellogg Code No.	Specifications on Page
301-TO		14
324-TO		14
397-TO		14

Three Conductor

Kellogg Code No.	Replaces Kellogg Code No.	Specifications on Page
309-TO		14
326-TO		14
390-TO	396-TO	14
391-TO		14

Steel and Tinsel Cords

Two Conductor

304-ST		15
323-ST		15
353-ST		15

Three Conductor

303-ST		15
325-ST		15
358-ST		15

Suspended Type Transmitter Cords

621-OT		10
465-T		10
499-T		10

Flexible, Insulated Stranded Wire

F-137		18
F-1107		18

Patching and Transmitter Cords

Kellogg Code No.	Replaces Kellogg Code No.	Specifications on Page Number
Patching Cord		15

KELLOGG EQUIVALENTS OF OTHER CORDS

Here are listed other manufacturers' cords and the code numbers of the Kellogg equivalents. In each case the Kellogg cord shown is the equivalent in size, trim, appearance and color, and is specifically designed to fit the same equipment as the cord it replaces. By equivalent we mean that the cords can be used in place of other manufacturers'

cords for the same purpose. Simply locate the cord you need in the left hand column, and order the Kellogg code number shown in the center column. For detailed information on any cord, refer to the drawing on the page indicated in the right hand column.

American, Automatic and Monarch Listed by Types

Handset Cords

American, Automatic and Monarch Numbers	Order Kellogg Equivalent	Specifications on Page Number
AH-11 replacing CD-301448	F-690-G	6
AH-11 replacing D-542271	F-690-G	6

Desk Stand Cords

AD-11 replacing CD-225472	F-720-D	10
AD-11 replacing D-541864-A	F-720-D	10
AD-11 replacing 542499-A	F-720-D	10

Receiver Cords

AR-11 replacing CD-104436	F-642-TR	11
AR-11 replacing MC-5430	F-642-TR	11
AR-12 replacing MC-5431	F-644-RA	11
AR-12 replacing MC-5431	F-644-RA	11
AR-31 replacing CD-100436	644-RA	11
AR-31 replacing MC-54201	644-RA	11
AR-31 replacing MC-5429	644-RA	11
D-541846	F-644-TR	11

Operator's Cords

DB-12 replacing CD-509464	722-O	13
DB-12 replacing MC-54220	713-O	13

Stromberg-Carlson Cords Listed by Types

Handset Cords

Stromberg-Carlson Code No.	Order Kellogg Equivalent	Specifications on Page Number
MC-3B	F-704-G	6
MC-3F	F-738-G	6
MC-4F	F-742-G	8

Desk Stand Cords

D-2C	F-665-D	8
MD-3C	F-686-D	9
MD-3F	F-686-D	9

Receiver Cords

MR-2G	F-687-TR	11
MR-2I	F-642-TR	11

Operator's Cords

MO-4F	722-O	13
-------	-------	----

Switchboard Cords

MS-22F	324-TO	14
MS-32K	390-TO	14

Western Electric Cords Listed by Types

Handset Cords

Western Electric Code No.	Order Kellogg Equivalent	Specifications on Page Number
H3B9	F-729-G	6

Desk Stand Cords

550	F-639-D	8
D3P9	F-730-D	8
D4S9	F-731-D	9
231	F-480-D	9
548	505-T	10
D-2-D	F-740-D	8
D-3-AL	F-739-D	9

Receiver Cords

R-2-B	F-732-R	11
549	646-TR	11

Operator's Cords

30	468-OR	12
254	466-OR	12
369	492-OR	12
L-2-C	726-T	12
L-4-B	709-O	13
L-4-R	743-O	13

Switchboard Cords

493	397-TO	14
S-2-A	397-TO	14
S-3-A	390-TO	14
S-3-B	391-TO	14
437	465-T	10

Leich Electric Cords Listed by Types

Receiver Cords

Leich Electric Code No.	Order Kellogg Equivalent	Specifications on Page Number
11-A	F-642-TR	11
11-B	644-TR	10
11-C	F-644-TR	10

Operator's Cords

31	708-OR	12
14-B	709-O	13
30-RL	713-O	13

Switchboard Cords

3-2 Conductor Cords	301-TO	14
---------------------	--------	----

Cord Section

SPECIFICATIONS and CORD DRAWINGS

Handset Cords

The conductors of Kellogg handset cords, like the desk stand cords, are made of six strands of highest quality bronze tinsel, each strand having spiral ribbons. This tinsel is absolutely sealed against moisture and oxidation by a special insulation. This is then protected by a closely woven cotton inner braid, and followed by the application of a heavy brown mercerized cotton outer braid. Terminals are firmly fastened, and grommets or tie cords are provided to take the strain off the conductors while in use.

This construction gives Kellogg cords the stamina to withstand the use and abuse of everyday service.

Any cord listed here can also be furnished in different lengths and trim to meet any special requirement. When ordering special cords, please be sure to specify the overall length, the length of the ends, and the code number of the terminals desired. Actual size drawings of terminals with code numbers are shown on page 16.

Three Conductor

Code No. F-673-G

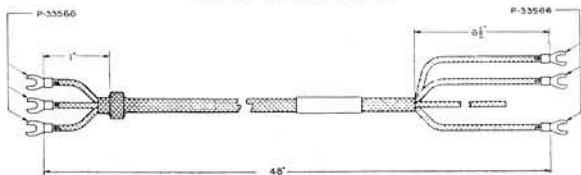

Tracer colors red, yellow, green. Fits Kellogg F-27-C handset used on Kellogg Masterphones of all types. Standard lengths are 48 inches. Also available in 72 inch lengths.

Code No. F-621-G

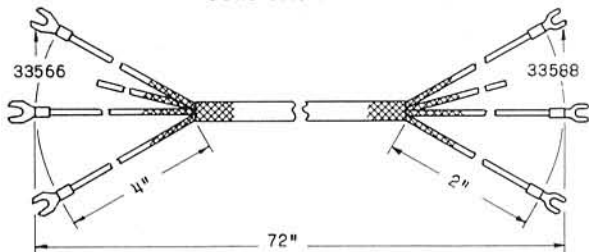

Tracer colors solid, black and yellow. Used with Kellogg No. 22-C handset.

Code No. F-688-G

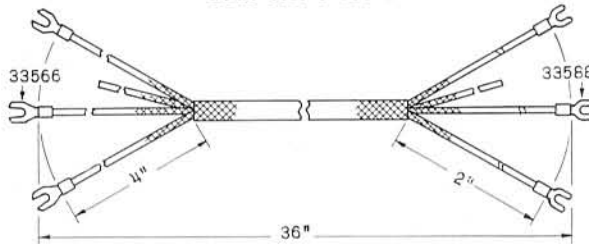

Rubber covered conductors are red, green and yellow. Fits Kellogg No. 32-C handset.

Code No. F-723-G

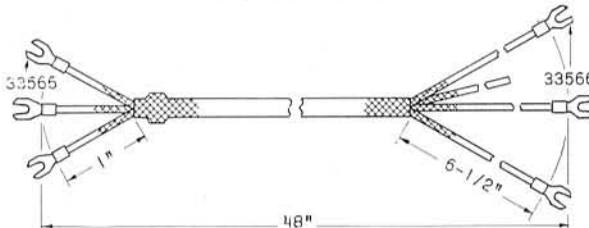

Rubber covered conductors are red, yellow and green. Fits Kellogg No. F-27-EC handset used with 4900 series weatherproof telephones.

Three Conductor — Continued

Code No. F-729-G

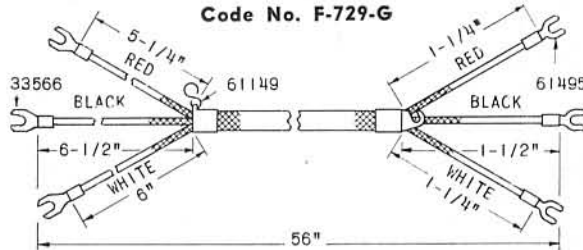

Rubber covered conductors are red, white and black. Replaces W. E. No. H3B9 cord. Used with W. E. No. E1B3 handset. Equipped with metal stay clip.

Code No. F-690-G

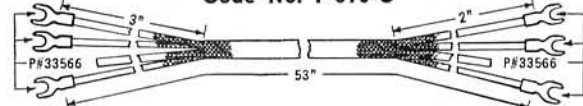

Tracer colors solid, red and yellow. Replaces A. E. No. AH-11, D-542271 and CD-301448 cords. Fits A. E. Monophones.

Code No. F-733-G

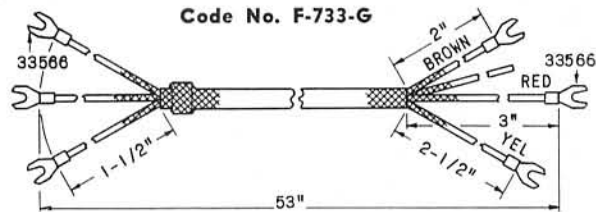

Tracer colors yellow, red and solid. Used with A. E. handset.

Code No. F-738-G

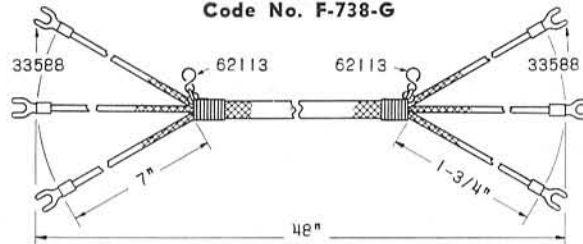

Tracer colors green, red and yellow. Replaces S. C. No. MC-3-F cord.

Code No. F-704-G

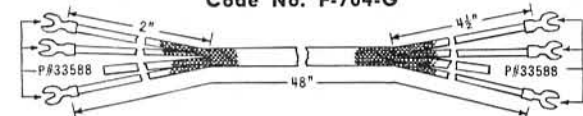

Tracer colors green, red and yellow. Replaces S. C. No. MC-3-B cord.

SPECIFICATIONS and CORD DRAWINGS

Handset Cords

Three Conductor — Continued

Code No. F-664-G

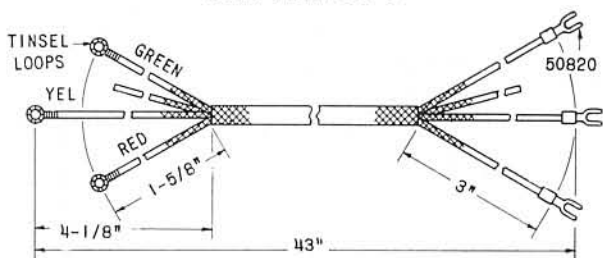

Tracer colors yellow, green and red. Used with Kellogg No. 19-L handset.

Four Conductor — Continued

Code No. F-717-G

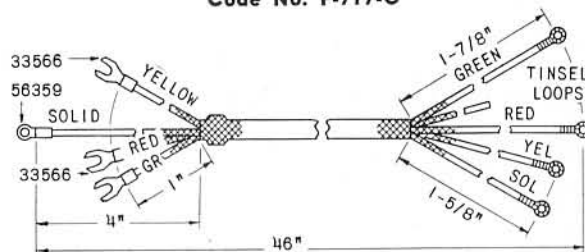

Tracer colors solid, yellow, red and green. Used with Kellogg No. 39 handset and No. 182 plug.

Four Conductor

Code No. F-698-G

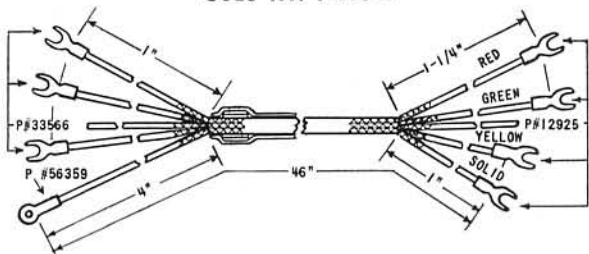

Tracer colors red, green, yellow and solid. Box end arranged to fit Kellogg No. 145 plug and Kellogg No. F-39-C handset.

Code No. F-734-G

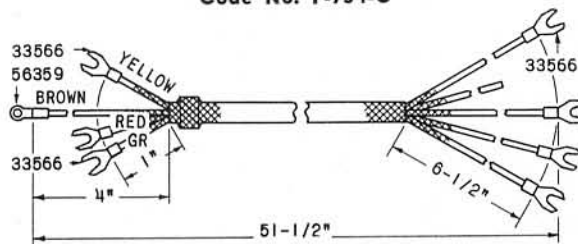

Tracer colors yellow, solid, red and green. Fits Kellogg No. F-43-C handset used in No. 5845 telephone.

Code No. F-699-G

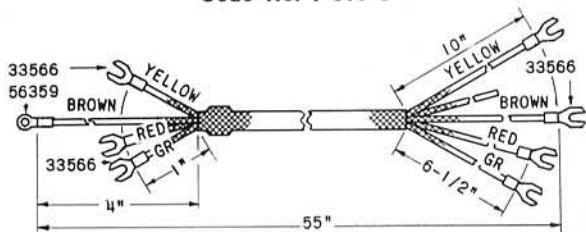

Tracer colors red, green solid and yellow. Terminals fit the receiver and transmitter binding posts in wall telephones when the conventional parts are replaced with a handset. Fits Kellogg No. F-40-C handset.

Code No. F-735-G

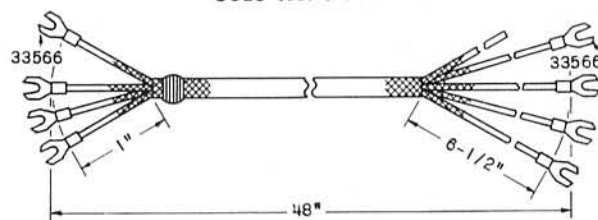

Rubber covered conductors are colored brown, yellow, red and green and are covered with a rubber jacket. This cord is used with Kellogg No. 44-C handset.

Code No. F-718-G

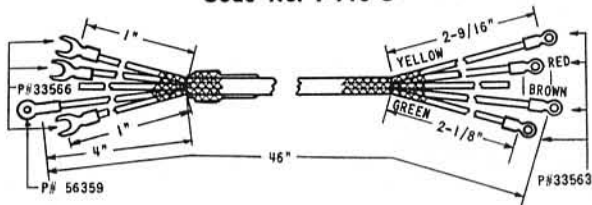

Tracer colors solid, yellow, red and green. Used with Kellogg No. 39 handset and No. 139 plug.

Code No. F-454-G

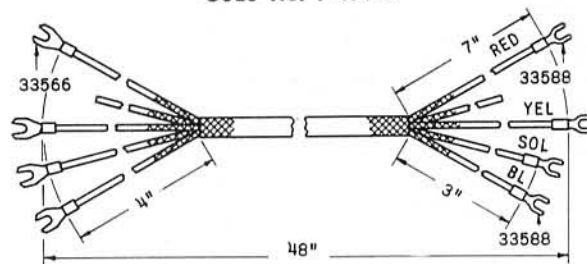

Tracer colors solid, black, red and yellow. Fits Kellogg No. F-11 and F-12 handsets.

CORD SECTION

SPECIFICATIONS and CORD DRAWINGS

Handset Cords Four Conductor — Continued Code No. F-742-G

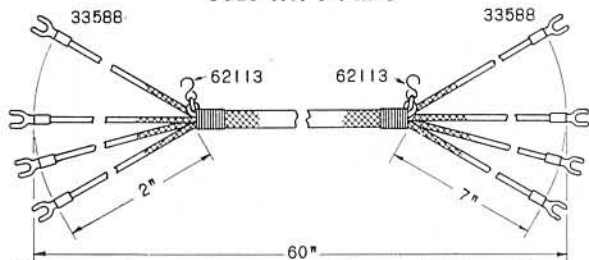

Tracer colors red, green, yellow and blue. Replaces S. C. No. MC-4-F cord.

Desk Stand Cords

Kellogg desk stand cords are of the same sturdy construction as Kellogg handset cords. This insures long life, high conductivity and resistance to moisture. The cords listed here fit Kellogg equipment and equipment of other makes. Cords to meet other requirements than those listed can be quickly furnished on order.

Any cord listed here can also be furnished in different lengths and trim to meet any special requirement. When ordering special cords, please be sure to specify the overall length, the length of the ends, and the code number of the terminals desired. Actual size drawings of terminals, with code numbers are shown on page 16. If convenient send a sketch of the cord you want with the information, or better yet, send one of your old cords as a sample. This assures prompt, satisfactory service.

Two Conductor Code No. F-665-D

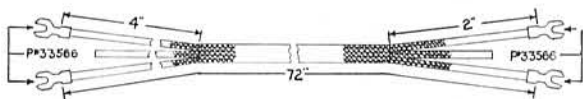

Tracer colors solid and black. Fits Kellogg No. F-39, F-75, F-97, F-111 and other stands provided with terminals for flat type tips and the No. 900 and 925 type Combination Masterphones. Replaces Kellogg No. F-100-D cord and S. C. D-2-C cord.

Code No. 665-D

Same as Code No. F-665-D except having No. 5006 spike or pin tips. Replaces Kellogg No. 100-D cord.

Code No. 667-D

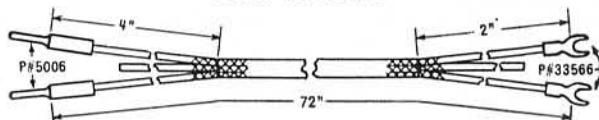

Tracer colors solid and black. Replaces Kellogg No. 581-D cord.

Code No. F-740-D

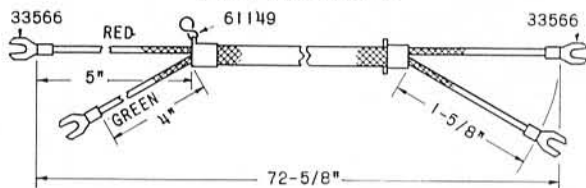

Rubber covered conductors are red and green. Replaces W. E. No. D-2-D cord.

Desk Stand Cords Three Conductor Code No. F-639-D

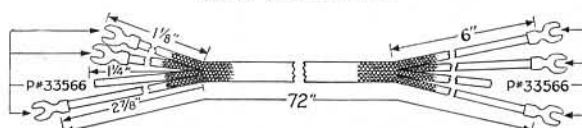

Tracer colors green, red and yellow. Replaces Kellogg No. F-479-D and W. E. No. 550 cords. Standard length is 72 inches. Also available in 96 and 108 in. lengths.

Code No. F-730-D

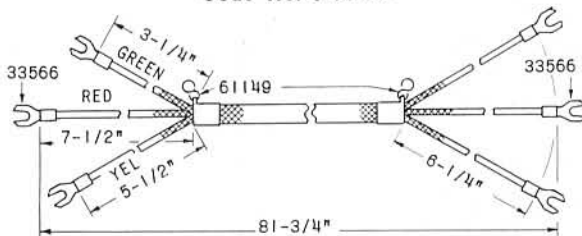

Green, red and yellow, rubber covered conductors. Replaces W. E. No. D3P9 cord. Equipped with metal stay clip.

Code No. F-640-D

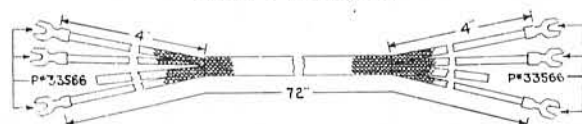

Tracer colors green, red and yellow. Fits Kellogg No. F-115-A, F-118, F-118-B, F-135, F-138 and F-301 stands and the 900 and 925 "B" type Combination Masterphones. Replaces Kellogg No. F-636-D cord. Standard length is 72 inches. Also available in 96, 120 and 144 in. lengths.

Code No. F-641-D

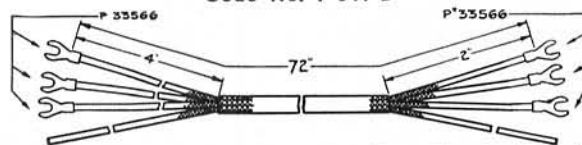

Tracer colors solid, black and yellow. Fits Kellogg No. F-84, F-110, F-115 and other stands provided with terminals for flat tips. Replaces Kellogg No. F-150-D cord. Standard length is 72 inches. Also available in 96 and 120 in lengths.

Code No. 641-D

Same as above except having No. 5006 spike or pin tips. Replaces Kellogg No. 150-D cord.

Code No. 669-D

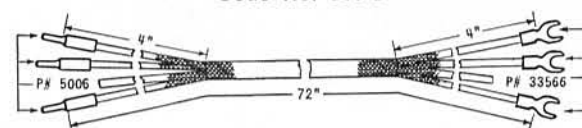

Tracer colors solid, red and yellow. A general purpose replacement cord for old style equipment. Replaces Kellogg No. 452-D cord.

SPECIFICATIONS and CORD DRAWINGS

Desk Stand Cords

Three Conductor — Continued

Code No. F-674-D

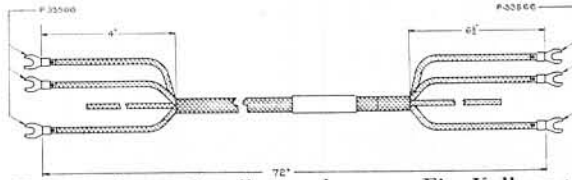

Tracer colors red, yellow and green. Fits Kellogg type 700, 725, 900-A and 925-A Masterphones.

Code No. F-739-D

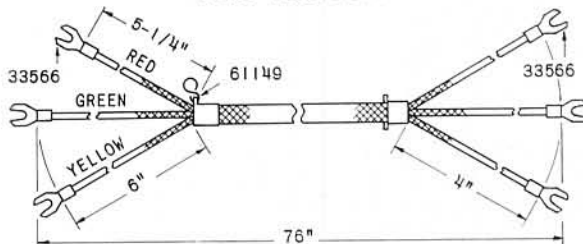

Colored rubber conductors are red, green and yellow. Replaces W. E. No. D-3-AL cord.

Code No. F-686-D

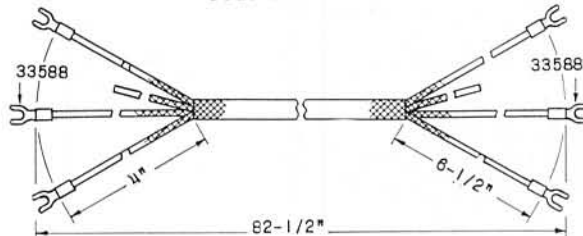

Tracer colors green, red and yellow. Replaces S. C. No. MD-3-C and MD-3-F cords. Standard length is 82 1/2 inches. Also available in 72 inch lengths.

Four Conductor

Code No. F-685-D

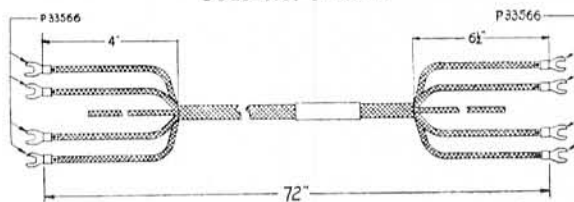

Tracer colors solid, red, yellow and green. Fits Kellogg type 710, 730, 900 and 925 Masterphones.

Code No. 189-D

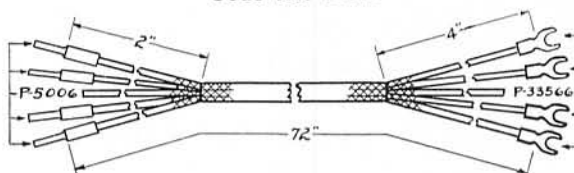

Tracer colors solid, black, red and yellow. Fits most four-conductor stands where a spike or spade terminal can be used.

Four Conductor — Continued

Code No. F-666-D

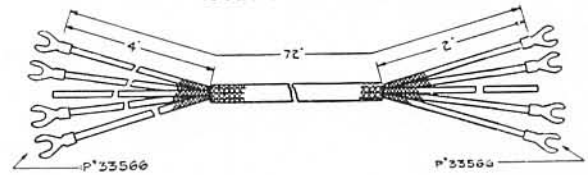

Tracer colors solid, black, red and yellow. For four-conductor magneto stands and desk set boxes provided with terminals for flat type tips. Replaces Kellogg No. F-102-D cord.

Code No. 666-D

Same as No. F-666-D, except has spike or pin tips No. 5006. Replaces Kellogg No. 102-D cord.

Code No. F-480-D

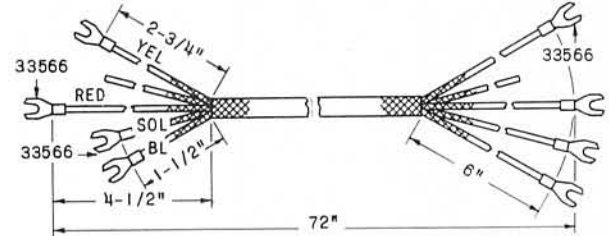

Tracer colors solid, black, red and yellow. Replaces W. E. No. 231 cord.

Code No. F-731-D

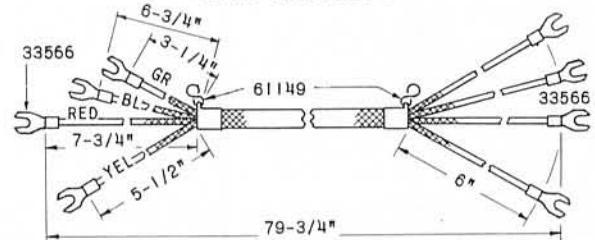

Green, red, yellow and black rubber covered conductors. Replaces W. E. No. D4S9 cord. Equipped with metal stay clip.

Code No. 487-D

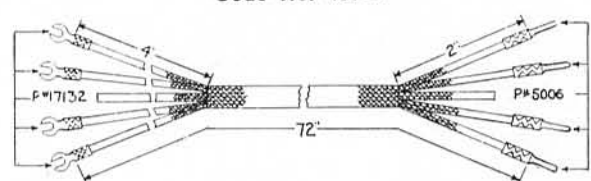

Tracer colors solid, black, red and yellow. Fits Monarch magneto stands.

Cord Section

SPECIFICATIONS and CORD DRAWINGS

Desk Stand Cords

Five Conductor

Code No. F-103-D

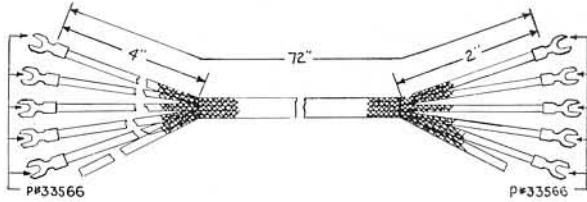

Tracer colors solid, black, red, yellow and white. Principally used with inter-communicating systems.

Code No. 103-D

Same as Code No. F-103-D except having spike or pin tips No. 5006.

Code No. 488-D

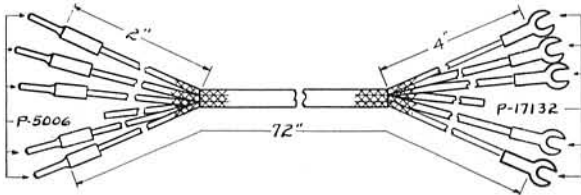

Tracer colors solid, black, red, yellow and white.

Code No. F-720-D

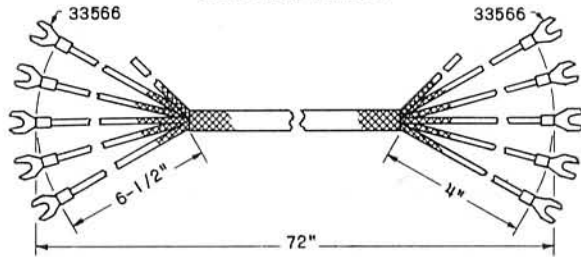

Tracer colors green, red, yellow, black and white. Replaces A. E. No. AD-11, CD-225472, D-541864-A and 542499-A cords.

Six Conductor

Code No. F-679-D

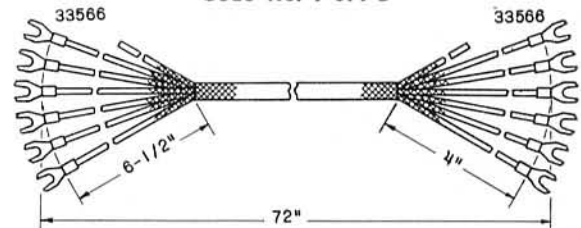

Tracer colors green, black, red, yellow, white and blue.

Desk Stand Cords

Seven Conductor

Code No. F-680-D

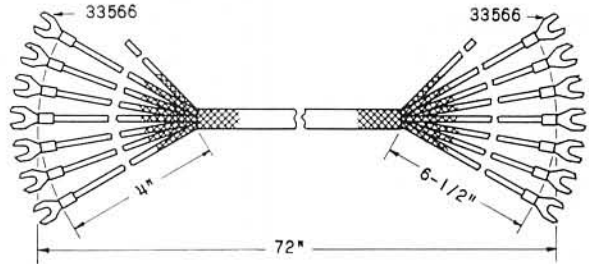

Tracer colors blue, red, yellow, solid, black, white and green.

NOTE

Other multi-conductor cords with various tracer colors, overall lengths, length of ends, and with any type terminal can be supplied on order. Simply send specifications, a sketch, or better yet, a sample.

Desk Stand Transmitter Cords

Code No. 505-T

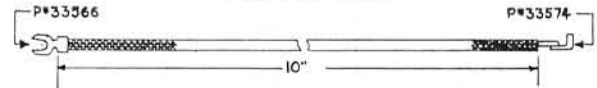

Code No. 505-T transmitter cord replaces W. E. No. 548. It is of the same construction as Kellogg desk stand cordage except with green overall braid.

Switchboard Suspended Type Transmitter Cords

Kellogg switchboard transmitter cords are of the same construction as Kellogg desk stand cords. They can be relied upon for long life, high conductivity and resistance to moisture.

Code No. 499-T

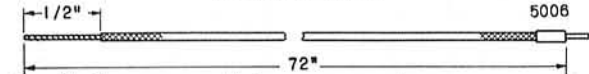

For Kellogg suspended type transmitter.

Code No. 465-T

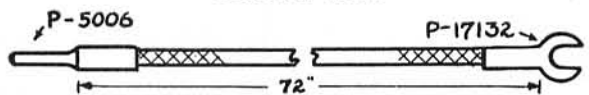

Replace W. E. No. 437.

Code No. 261-OT

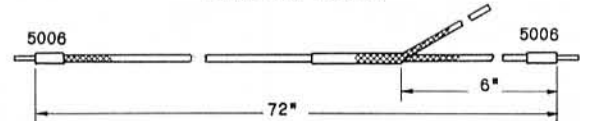

A general purpose single conductor cord for suspended type transmitter or test set use.

SPECIFICATIONS and CORD DRAWINGS

Receiver Cords

Kellogg receiver cords, like Kellogg desk stand cords are so widely used because of their long life, high conductivity and resistance to moisture qualities. They are of the same construction as the desk stand cords. Listed below are cords to fit all standard Kellogg receivers, and receivers of other makes. Cords requiring length and terminals differing from those here listed, can be quickly furnished to meet special requirements. Simply send a rough sketch showing, size, trim and terminal specifications, or better yet, send one of your old cords as a sample.

Two Conductor

Code No. F-644-TR

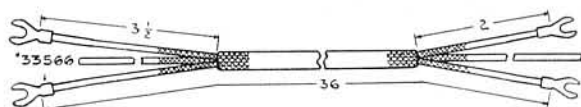

Tracer colors solid and black. Replaces Kellogg No. F-98-TR, Leich No. 11-C and A. E. No. D-541846 cords. Fits Kellogg F-41-A and F-41-B receivers, etc.

Code No. 644-TR

The 644-TR is the same as F-644-TR except with spike or pin tips No. 5006. Replaces Kellogg No. 98-TR cord and Leich No. 11-B cord.

Code No. F-716-TR

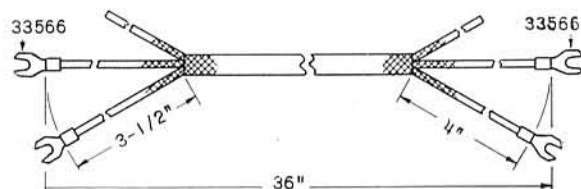

The F-716-TR is the same as F-644-TR except conductor insulator is rubber instead of silk. Used in Kellogg No. 4901 outdoor telephone with No. F-41-EA receiver. For use wherever a weatherproof cord is required.

Code No. F-642-TR

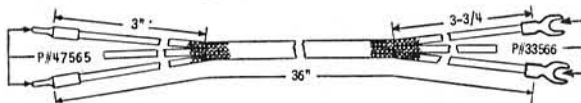

Tracer colors solid and black. Replaces Kellogg No. 197-TR cord; S. C. No. MR-2-I cord; A. E. No. AR-11, CD-104436 and MC-5430 cords and Leich No. 11-A cord.

Code No. 646-TR

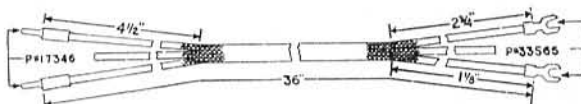

Tracer colors white and green. Replaces Kellogg No. 207-TR cord and W. E. No. 549 cord. Standard for W. E. desk stand, also for W. E. No. 40-P transmitter arm.

Two Conductor — Continued

Code No. 682-TR

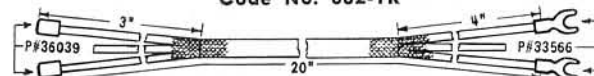

Tracer colors solid and black. Used with Kellogg weather-proof telephone No. 4883 and Kellogg receiver No. 81-A.

Code No. F-732-R

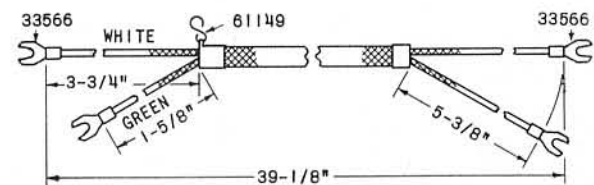

Green and white rubber covered conductors. Replaces W. E. No. R2B cord. Used with W. E. desk stands No. 51-C, 51-AL or 51-CN with No. 144 receiver. Also used with W. E. No. 20-CC transmitter arm. Equipped with metal stay clip.

Code No. F-644-RA

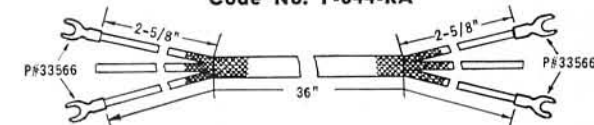

Tracer colors red and green. Replaces A. E. No. AR-12, M-5431 and CD-109436 cord.

Code No. 644-RA

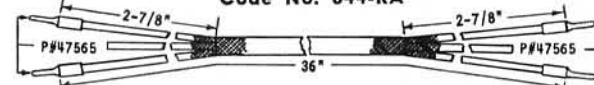

Tracer colors red and green. Replaces A. E. No. AR-31, CD-100436, MC-54201 and MC-5429 cords.

Code No. F-687-TR

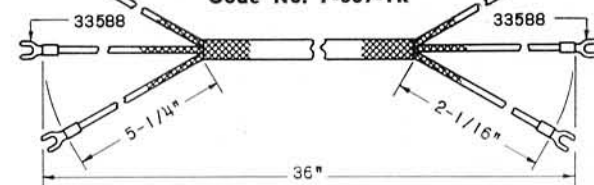

Tracer colors solid and black. Used with Kellogg No. 80-A receiver in Kellogg No. F-2945 Telephone. Replaces Kellogg No. 668-TR. Replaces S. C. No. MR-2-G.

Code No. 617-TR

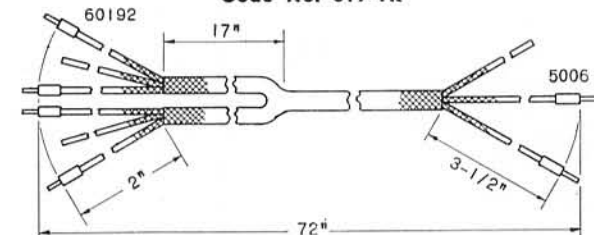

72-inch cord made to fit double head set with receivers in series. Pin tips.

Cord Section

SPECIFICATIONS and CORD DRAWINGS

Operator's Cords — For Head Receivers

Kellogg operator's cords are of the same construction as Kellogg desk stand cords. They are purchased for their long life, high conductivity and resistance to moisture qualities.

The conductors are made of a high quality bronze tinsel scientifically braided to give maximum wear and flexibility. Kellogg cords withstands the twisting, jerking and bending which operator's cords are constantly subjected to without noising up. The tinsel conductor is absolutely sealed against moisture and oxidation by the use of special insulation.

All standard cords for Kellogg operators' equipment are listed below. In addition, there are cords to fit other makes of equipment. Cords requiring different length and trim than those shown can be quickly furnished to meet special requirements. When ordering cords not listed please send complete information, including a sketch. When possible send sample of an old cord.

NOTE: Cords with spike tips may be used with equipment requiring plug type tips by simply trimming the ends off the spike tips.

Two Conductor

Code No. 708-OR

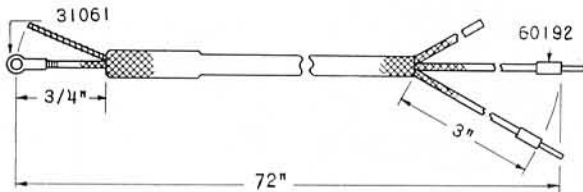

Tracer colors solid and black. Diameter at plug end .292 to .312 inch for 5/16 inch, 18 Whit. Tap. Formerly standard on Kellogg switchboards. Replaces Kellogg No. 26-OR cord and Leich No. 31 operator's receiver cord. Fits Kellogg No. 107 and 247 and W. E. No. 47 plugs.

Code No. 710-OR

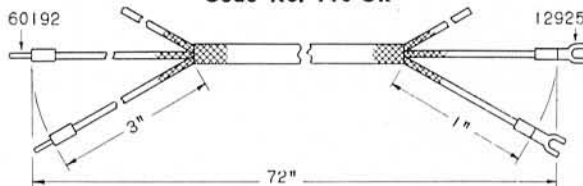

Tracer colors solid and black. Replaces Kellogg No. 110-OR cord. Standard on Kellogg boards using suspended type transmitter. Fits Kellogg No. 145 and 146 plugs and Kellogg receiver No. 85-A.

Code No. 237-OR

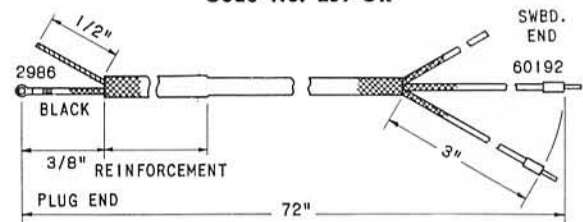

Tracer colors solid and black. Diameter at plug end .196 to .216 inch for 12-24 Whit. Tap. Fits Kellogg No. 75 plug.

Two Conductor — Continued

Code No. 466-OR

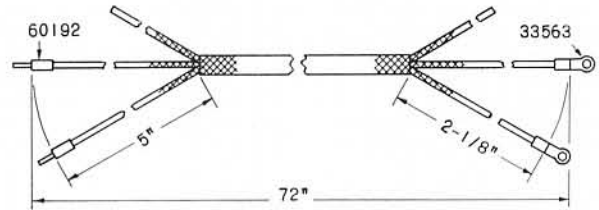

Tracer colors solid and black Fits Kellogg No. 139 plug. Replaces W. E. cord No. 254.

Code No. 719-OR

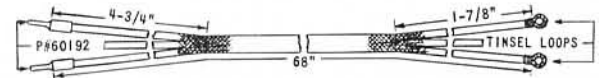

Tracer colors red and yellow. Used with Kellogg No. 182 plug.

Code No. 468-OR

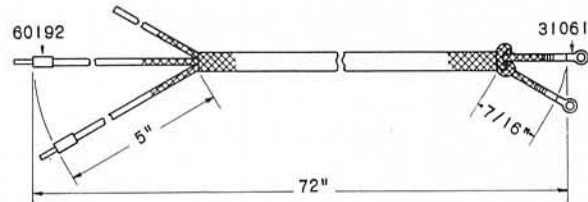

Tracer colors solid and black. Knotted at plug end. Replaces W. E. No. 30 cord.

Code No. 492-OR

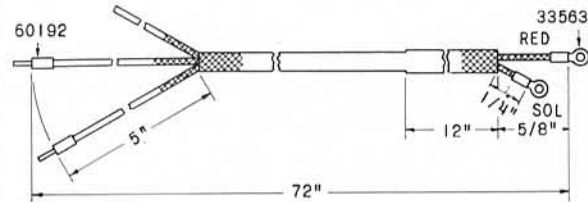

Tracer colors solid and red. Replaces W. E. No. 369 cord.

NOTE: See page 10 for Suspended Type Transmitter Cords.

Breastplate Transmitter Cord

Two Conductor

Code No. 726-T

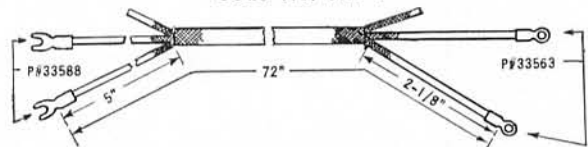

Tracer colors solid and black. Replaces W. E. cord No. L-2-C.

SPECIFICATIONS and CORD DRAWINGS

Operator's Cords — For Breastplate Transmitter Type Operator's Sets

Four Conductor

Code No. 712-O

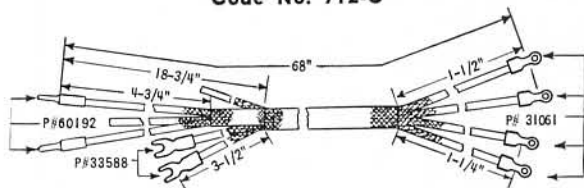

Transmitter tracer colors solid and black; receiver tracer colors red and yellow. Replaces Kellogg No. 67-O cord. Fits Kellogg No. 25 plug.

Code No. 709-O

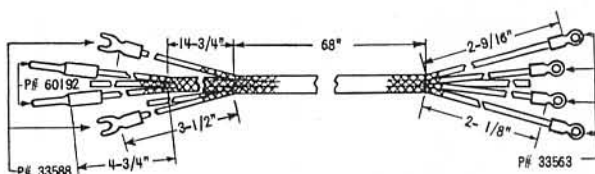

Transmitter tracer colors solid and blue; receiver tracer colors are red and yellow. Replaces Kellogg No. 199-O cords; W. E. No. L4B cords and Leich No. 14-B cords. Fits Kellogg No. 139 plug and W. E. No. 103, 112 and 137 plugs.

Code No. 721-O

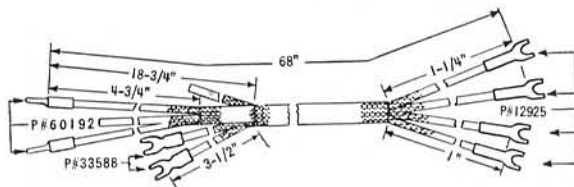

Transmitter tracer colors black and solid; receiver tracer colors red and yellow. Replaces Kellogg No. 670-O cord. Fits Kellogg No. 145 plug.

Code No. 722-O

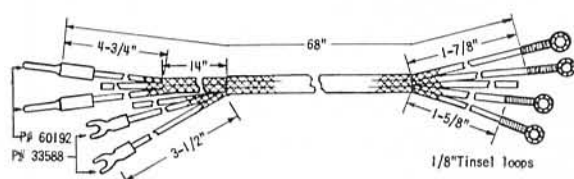

Transmitter tracer colors black and solid; receiver tracer colors red and yellow. Replaces Kellogg No. 672-O cord; A. E. cords No. DB-12, MC-54220 and CD-509464 and S. C. No. MO-4-F. Fits Kellogg No. 182 plug.

Four Conductor — Continued

Code No. 711-O

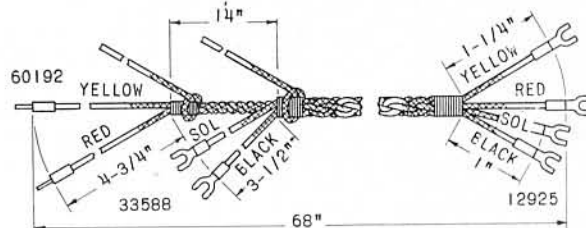

Transmitter tracer colors solid and black; receiver tracer colors red and yellow. Replaces Kellogg No. 111-O cord. Used with Kellogg No. 145 plug.

Code No. 713-O

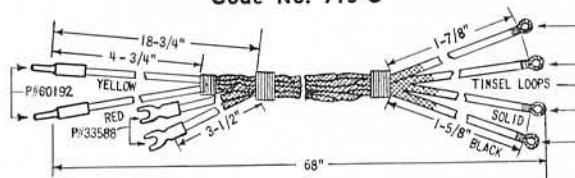

Transmitter tracer colors solid and black; receiver tracer colors red and yellow. Replaces Kellogg No. 439-O cord; A. E. cords No. DB-12, MC-54220 and CD-509464 and Leich No. 30-RL cord. Used with Kellogg No. 182 plug.

Code No. 741-O

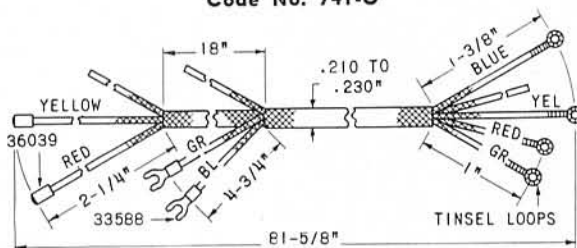

Tracer colors: transmitter green and blue; receiver yellow and red.

Code No. 743-O

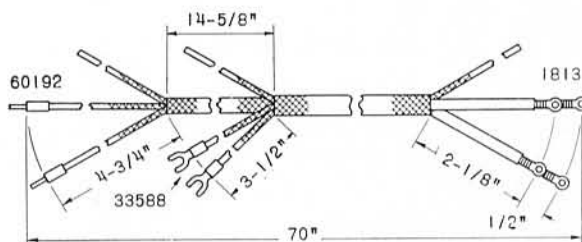

Tracer colors: transmitter, solid and blue; receiver, red and yellow. Fits W. E. plug No. 289-A. For use with Kellogg No. 85-A receiver and No. 177 transmitter. May be furnished to fit W. E. No. 396-A transmitter on special order. (Replaces W. E. cord No. L-4-R).

Cord Section

SPECIFICATIONS and CORD DRAWINGS

Switchboard Cords — Tinsel

The use of Kellogg all tinsel switchboard cords is a real economy in switchboard maintenance. They combine low resistance, extreme flexibility and long life. Recommended for Kellogg Service switchboards and other equipment where traffic is heavy and operators work at high speed.

The conductors are made of a high quality bronze tinsel. A durable, moisture-proof covering of the finest insulating material obtainable is applied to the conductors. The individual conductors are then twisted together with suffi-

cient rope filler to make a smooth, round cord. A cotton inner braid, and then a tough glazed outer braid is woven over the insulated conductors. A double layer of this tough outer braid material is applied for a distance of 12 inches from the plug end to give that extra reinforcement which prolongs cord life.

The standard color of the outer braid is white, but red or green can be furnished when specified. When desired, cords will be furnished complete with switchboard plugs attached. In such cases, furnish the code number of the plugs wanted. Specify the color of the outer braid.

Two Conductor

Code No. 301-TO

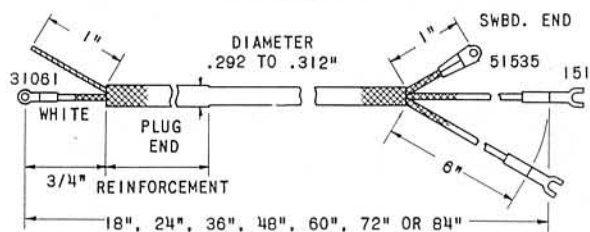

Diameter at plug end .292 to .312 inches. Fits Kellogg No. 3, 42, 70, 138 and 109 plugs and Leich No. 3A plug.

Three Conductor

Code No. 309-TO

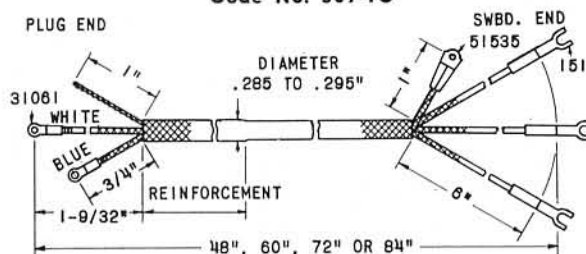

Diameter at plug end .285 to .295 inches. Fits Kellogg No. 12, 13, 106, 202 and 152 plugs. Colors: tip conductor white, ring conductor, blue and sleeve conductor, red.

Code No. 324-TO

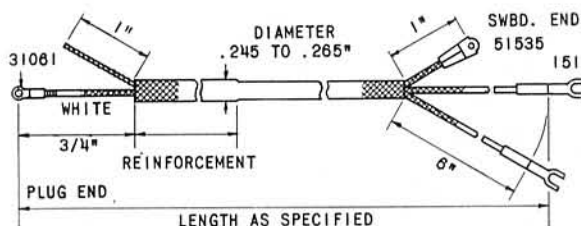

Tracer colors solid and blue. Replaces S. C. No. MS-22-F cord. Used with Kellogg plugs No. 141 and 211 and S. C. plugs No. 56 and 56-X. Also used with Garford 2-conductor plugs.

Code No. 326-TO

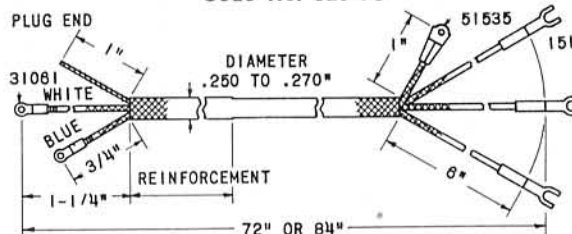

Diameter at plug end .250 to .270 inches. Fits Kellogg No. 201 plugs.

Code No. 397-TO

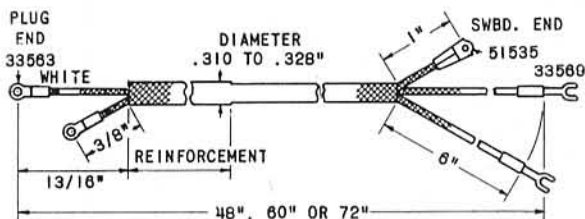

Diameter at plug end .310 to .328 inches. Fits W. E. No. 47 plug and Kellogg No. 247 plug. Replaces W. E. No. 493 and S-2-A cords.

Code No. 390-TO

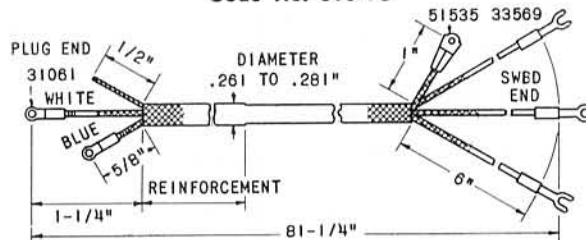

Diameter at plug end .261 to .281 inches. Replaces Kellogg cord No. 396-TO; S. C. cord No. MS-32-K and W. E. cord No. S-3-A. Fits Kellogg No. 185 plug and W. E. No. 109 plug.

Code No. 391-TO

Same as No. 390-TO except diameter at plug end is .292 to .312 inches. Replaces W. E. cord No. S-3-B. Fits Kellogg No. 191 plug and No. 110 plug.

SPECIFICATIONS and CORD DRAWINGS

Switchboard Cords — Steel and Tinsel

Kellogg steel and tinsel cords are known for their durability and the ease with which they may be cut back. They consist of spiral steel piano wire conductors wrapped over the finest quality braided tinsel. The steel gives the cord long life, while the tinsel furnished low resistance. This construction assures a most satisfactory cord from a transmission standpoint, and the most economical cord from the standpoint of service life.

When it is desired to have switchboard plugs attached to the cords at the Kellogg factory, please be sure to specify on your order the code number of the plug desired.

Two Conductor

Code No. 304-ST

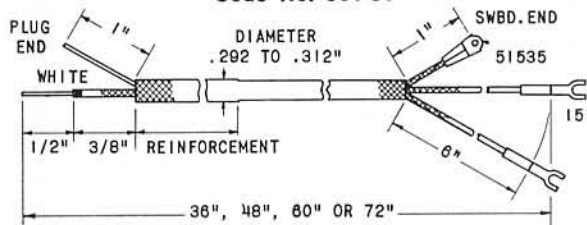

Kellogg standard diameter at plug end .292 to .312 inches. Fits Kellogg No. 3, 42, 70, 130 and 187 plugs and A. E. No. 1188 plugs.

Code No. 323-ST

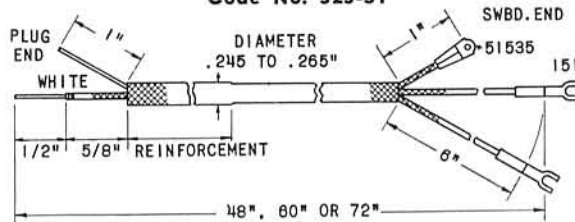

Diameter at plug end .245 to .265 inches. Fits Kellogg No. 211 and S. C. No. 56 and 67 plugs.

Code No. 353-ST

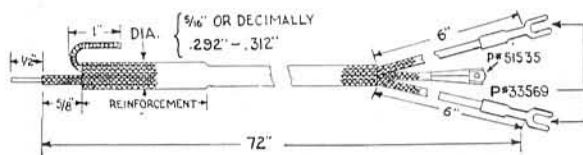

Diameter at plug end .292 to .312 inches. Fits W. E. No. 47 plug

Three Conductor

Code No. 303-ST

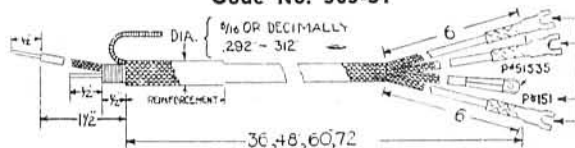

Diameter at plug end .292 to .312 inches. Fits Kellogg No. 12, 13, 74, 106, 152 and 202 Leich plugs. Colors: tip conductor, white; ring conductor, blue and sleeve conductor, red.

Three Conductor — Continued

Code No. 325-ST

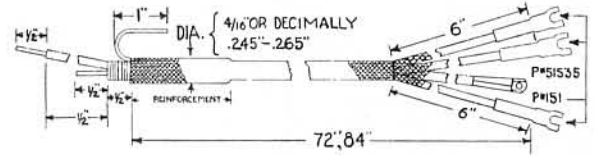

Diameter at plug end .245 to .265 inches. Fits Kellogg No. 201 plugs, Garford No. 54, and S. C. No. 55, 55-N and 55-NX plugs. Colors: tip conductor, white; ring conductor, blue and sleeve conductor, red.

Code No. 358-ST

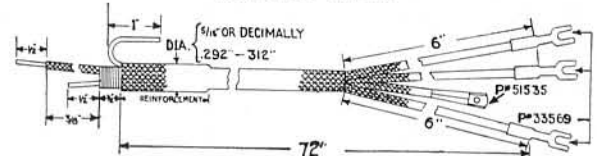

Diameter at plug end .292 to .312 inches. Fits Kellogg No. 191 and W. E. No. 110 plugs. Colors: tip conductor, white; ring conductor, blue and sleeve conductor, red.

Switchboard Patching Cords

Kellogg switchboard patching cords are made in a wide variety of types, to meet the requirements of all telephone exchanges. They are generally made to order to fit the exact condition of the central office equipment. These cords are made from one, two or three conductor switchboard cordage of either all tinsel, or steel and tinsel construction. When sending orders for, or requesting information on Kellogg switchboard patching cords, include a sketch or send a sample. The code number of the switchboard plugs required should also accompany the order.

Tools

No. 39



These pliers are used for attaching terminal No. 31061 to conductors in cutting back switchboard cords. The connection formed is neat and permanent and prevents loose connection trouble in cord circuits.

No. 42



Tool for skinning switchboard cable.

Cord Section

RUBBER PLUG CUSHIONS, CORD TIPS etc.

Rubber Plug Cushions

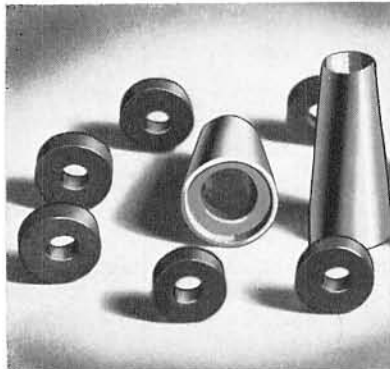

Rubber Plug Cushions and Plug Cushion Tools

These rubber rings fit snugly around the switchboard cord just below the plug. They protect the plug seat from the impact of the plug and also prevent rough and sharp edges from developing on the plug base. By eliminating these rough edges, the plug seats remain smooth and extra life is given to the cords. With the cushions, the

switchboard cords need not be "cut back" as often as before.

Quieter operation is assured by the use of these cushions which almost entirely eliminate the noise of falling plugs. They cost little, but they do a big job in protecting cord, plugs and plug seats from unnecessary wear. Made of high grade rubber, these plug cushions reduce your switchboard maintenance. They are put on in a jiffy with the aid of a small, cone-shaped brass tool which fits over the plug end providing a smooth, sloping surface over which the rubber cushion is to slide.

Plug Cushions

1-A Used with Kellogg plugs No. 106, 42 and others taking the same diameter cords.

2-A Used with Kellogg plugs No. 201 and others taking the same diameter cords.

Shipped in lots of 100.

Plug Cushion Tools

100 For use with Kellogg No. 106 plug or any plug having a sleeve diameter of .2495 inch.

102 For use with Kellogg No. 201 plug or any plug having a sleeve diameter of .2215 inch.

Cord Fasteners

No. 4

Made of brass, dull nickered. Illustrated at left.



No. 5

Made of steel, hot tin plated. Illustrated at right.

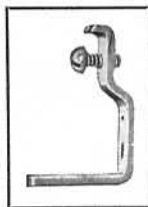

Cord Hooks

No. 2 cord hook is made from No. 11 B&S gauge brass. Bent to form loop to prevent cord from slipping off.



Cord Tips

Actual Size

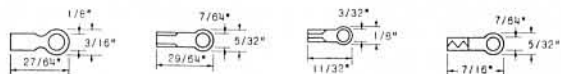

No. 33563 No. 1813 No. 2986 No. 31061

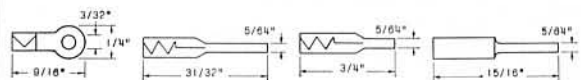

No. 56359 No. 5006 No. 17346 No. 47565

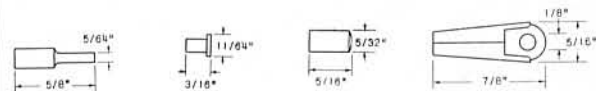

No. 60192 No. 33574 No. 36039 No. 51535

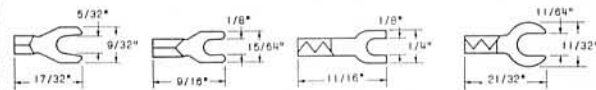

No. 33566 No. 33588 No. 12925 No. 17132



No. 151 No. 33569

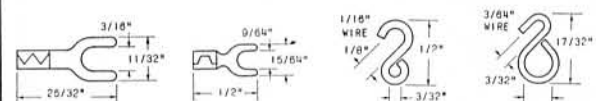

No. 50820 No. 61495 No. 62113 No. 61149

Cord Weight



Code No. 9 cord weight is the standard weight for promptly restoring switchboard cords to their proper position after use. Weighing from 9 to 11 ounces, this cord weight will perform its task quickly yet not damage the cord by being too heavy. The steel casing is given a rustproof treatment before being filled with lead to add weight. Dimensions are 4 inches long, 1-23/32 inches wide and 1/2 inch thick.

SWITCHBOARD CABLE

For Other Wire See Line Supplies Section

Switchboard Cable Braid Covered

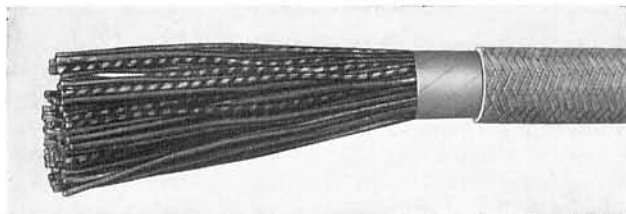

Kellogg switchboard cables are manufactured from the best grades of selected raw materials by specially designed machinery, and are furnished in several styles and sizes.

The wires are tinned, thoroughly annealed, and are of not less than 98 per cent pure copper, evenly coated with tin. Only the best grade of cellulose acetate yarn and cotton wrappings are used for insulation. After the insulation is applied, the twisted pairs are formed into a cable and covered with several wraps of heavy manila paper and then thoroughly saturated with beeswax. This cable is regularly furnished with single wrappings of cellulose acetate yarn over enameled wire or with a double wrap of cellulose acetate yarn and cotton insulation over tinned wire. The standard overall covering is of braided cotton, saturated with a lead colored, fire-proof paint.

A standard color code is used so that each pair of wires can be identified. Short lengths of cable will be shipped in boxes. Longer lengths will be packed and shipped on suitable reels. When reels are furnished they will be charged for. Full credit will be allowed for their return in good condition, prepaid to the Kellogg factory.

Round Type, 22 B.&S. Gauge, Wax Core

Two Cellulose Acetate Yarn and One Cotton - Tinned

Code No.	No. of Pairs	No. of Singles	Diameter Overall, Inches	Approximate Net Weight Per 1000 Ft.
56-A	7	..	$\frac{1}{16}$	63 lbs.
65-A	11	..	$\frac{3}{32}$	86 lbs.
99-A	11	11	$\frac{3}{32}$	120 lbs.
42-A	21	..	$\frac{1}{8}$	145 lbs.
41-A	21	21	$\frac{1}{8}$	206 lbs.
112-A	26	..	$\frac{1}{8}$	173 lbs.
125-A	41	..	$\frac{5}{16}$	252 lbs.
63-A	51	..	$\frac{5}{16}$	312 lbs.
62-A	102	..	$\frac{1}{4}$	622 lbs.

One Cellulose Acetate Yarn and One Cotton - Tinned Enameled

Code No.	No. of Pairs	No. of Singles	Diameter Overall, Inches	Approximate Net Weight Per 1000 Ft.
114-AX	11	..	$\frac{3}{32}$	83 lbs.
137-AX	11	11	$\frac{3}{32}$	119 lbs.
100-AX	16	..	$\frac{1}{8}$	116 lbs.
107-AX	21	..	$\frac{1}{8}$	132 lbs.
22-AX	21	21	$\frac{1}{8}$	163 lbs.
33-AX	26	..	$\frac{1}{8}$	164 lbs.
109-AX	41	..	$\frac{5}{16}$	246 lbs.
29-AX	51	..	$\frac{5}{16}$	304 lbs.
53-AX	102	..	$\frac{1}{4}$	623 lbs.

Switchboard Cable Braid Covered

Flat Type, 22 B.&S. Gauge, Wax Core

One Cellulose Acetate Yarn and One Cotton - Tinned Enameled

Code No.	No. of Pairs	Dimensions, Inches	Approximate Net Weight Per 1000 Ft.
104-AX	41	$\frac{7}{16} \times \frac{3}{4}$	256 lbs.

Two Cellulose Acetate Yarn and One Cotton - Tinned

Code No.	No. of Pairs	No. of Singles	Dimensions, Inches	Approximate Net Weight Per 1000 Ft.
135-A	21	21	$\frac{5}{16} \times 1$	242 lbs.
119-A	41	..	$\frac{7}{16} \times \frac{3}{4}$	266 lbs.

Round Type, 19 B.&S. Gauge, Wax Core

Two Cellulose Acetate Yarn and One Cotton - Tinned

Code No.	No. of Pairs	Diameter Overall, Inches	Approximate Net Weight Per 1000 Ft.
81-A	16	$\frac{3}{16}$ in.	181 lbs.
85-A	21	$\frac{1}{4}$ in.	234 lbs.

Lead Covered Cable

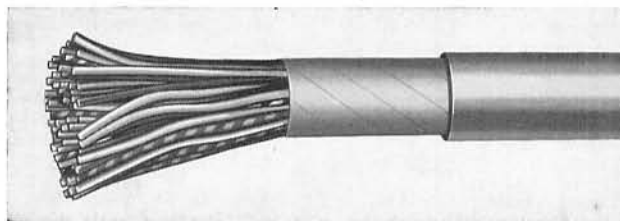

The construction of this lead covered cable is the same as the cable shown at left except that a lead sheath instead of a painted braid covers the paper wrapping.

22 B.&S. Gauge, Wax Core

One Cellulose Acetate Yarn and One Cotton - Tinned

Code No.	No. of Pairs	Thickness of Sheath, Overall	Diameter Overall, Inches	Approximate Net Weight Per 1000 Ft.
148-L	13	$\frac{3}{16}$	$\frac{3}{16}$	442 lbs.
144-L	16	$\frac{3}{16}$	$\frac{3}{16}$	544 lbs.
121-L	21	$\frac{3}{16}$	$\frac{3}{16}$	670 lbs.
147-L	26	$\frac{3}{16}$	$\frac{3}{16}$	730 lbs.
146-L	51	$\frac{1}{8}$	$\frac{1}{8}$	1080 lbs.
145-L	102	$\frac{1}{8}$	1 $\frac{3}{16}$	1790 lbs.

Lacing Twine

Commonly called lock stitch, lacing twine possesses unusual strength. Used for lacing wires in special keyboard and switchboard cable. Put up in one pound balls.

Code No.	Description
6	Waxed, Light Weight
9	Waxed, Medium Weight
11	Waxed, Heavy Weight

Note

Types and sizes listed on this page are those for which there is a general demand and which are normally carried in stock for immediate shipment.

The large, well equipped Kellogg cable plant is pre-

pared to furnish a wide variety of other types and sizes on special order. We are also prepared to furnish lacquer impregnated cables made to your order. Your specifications will bring a prompt quotation.

Cord Section

POWER CABLE, SWITCHBOARD and CABLE WIRE

For Other Wire See Line Supplies Section

Power Cable

For Carrying Ringing Circuits Through Key Cables

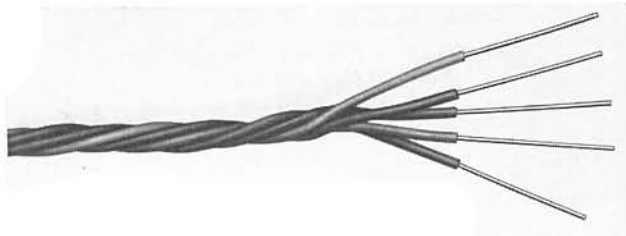

Consists of No. 22 B.&S. gauge single wires twisted into a cable having no overall braid. Each wire is insulated with enamel and two reverse cellulose acetate yarn wraps and one cotton wrap.

Code No.	No. of Conductors	Diameter Overall	Approximate Net Weight Per 1000 Ft.
71-X	5	7/64 in.	15 lbs.
72-X	9	5/32 in.	26 lbs.

For Carrying Power Circuits From Ringing Equipment Leads to Key Cables

Consists of No. 20 B.&S. gauge single wires twisted into a cable having no overall braid. Each wire is insulated with enamel and two reverse cellulose acetate yarn wraps, one cotton wrap and a cotton braid.

Code No.	No. of Conductors	Diameter Overall	Approximate Net Weight Per 1000 Ft.
101-X	5	13/64 in.	29 lbs.
102-X	7	7/32 in.	40 lbs.
103-X	9	21/64 in.	51 lbs.

For Leads From Ringing Equipment to Switchboard

Consists of No. 18 B.&S. gauge single wires twisted into a cable having no overall braid. Each wire is insulated with rubber and a color coded cotton braid.

Code No.	No. of Conductors	Diameter Overall	Approximate Net Weight Per 1000 Ft.
59	5	27/64 in.	65 lbs.
105	7	15/32 in.	91 lbs.
66	9	35/64 in.	117 lbs.

59-L Same as No. 59 with lead sheath overall.
105-L Same as No. 105 with lead sheath overall.

For Leads From Power Boards to Ringing Apparatus

Consists of one No. 14 B.&S. gauge and eleven No. 18 B.&S. gauge single wires twisted into a cable having no overall braid. Each wire is insulated with rubber and a cotton overall braid.

Code No.	No. of Conductors	Diameter Overall	Approximate Net Weight Per 1000 Ft.
122	12	5/8 in.	156 lbs.

Flexible, Insulated, Stranded Wire

For Transmitter and Ringer Leads

F-137 wire is extensively used in Kellogg desk and wall telephones. It consists of 15 strands of bare copper wire of finest quality over which is placed two cellulose acetate yarn wrappings followed by a blue and red cotton overall, non-raveling braid. F-1107 consists of 16 strands of tinned copper with 1/64 inch rubber cover, and braided same as F-137.

Code No.	Color	Approximate Ft. Per Lb.
F-137	Blue and Red	165
F-1107	Blue and Red	110

Switchboard Wire

Single



Switchboard wire is the tinned copper wire used in Kellogg switchboard cable. The insulation consists of one or two wrappings of cellulose acetate yarn next to the wire, followed with a cotton wrapping, all of which is then saturated with wax. This wire can be furnished with tinned or tinned enameled conductors, as specified, in all standard cable colors. No. 22 B.&S. gauge is standard.

Specify whether tinned or tinned enameled conductors are desired.

Gauge	No. of Conductors	No. Feet Per Lb.
19 B.&S. Gauge	One	210 Feet
22 B.&S. Gauge	One	400 Feet
24 B.&S. Gauge	One	550 Feet

Duplex

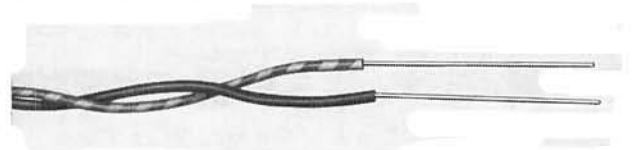

Can be supplied in all standard color combinations as used in standard cable, in 22 B.&S. gauge. Specify whether tinned or tinned enameled conductors are desired.

Gauge	No. of Conductors	No. Feet Per Lb.
22 B.&S. Gauge	Two	195 Feet

Telephone Cable Wire

Also known as push back or hook up wire. Cable wire is used for wiring telephones and can be furnished in a variety of colors, made in single conductor only. The conductor is No. 20 B.&S. gauge tinned copper wire, insulated with one wrapping of cellulose acetate yarn and one of cotton applied in reverse directions. On top of this a cotton braid is applied tightly so as to cause the insulation to adhere closely to the wire. The wire is then saturated in wax, making it moisture proof.

Code No.	Color	Feet Per Lb.	Code No.	Color	Feet Per Lb.
F-661	Red	> 180	F-851	White, Green	180
F-663	Brown	180	F-853	White, Black	180
F-665	Orange	> 180	F-855	White, Red	180
F-667	Green	> 180	F-857	White, Orange	180
F-669	Black	> 180	F-859	White, Blue	180
F-844	White	180	F-863	White, Brown	180
F-846	Slate	180			

GENERATOR and FLAMEPROOF JUMPER WIRE

For Other Wire See Line Supplies Section

Generator Wire

Duplex — 20 B.&S. Gauge

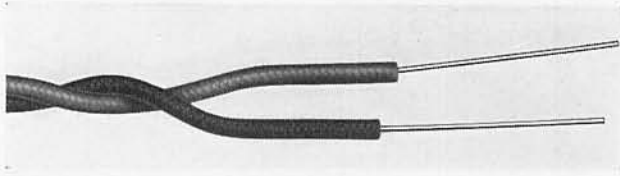

The individual conductors of generator wire are the same as for Cable Wire shown on page 18 except for gauge and that the generator wire has an extra wrap of cellulose acetate yarn.

Code No.	Colors	No. Feet Per Pound
F-925	Red, Black	92 Feet
F-927	Brown and Brown White	92 Feet
F-928	Orange Green and Orange Black	92 Feet

Single — 16 B.&S. Gauge



Same as the individual conductors of the duplex wire shown above. This wire can also be furnished with the conductors having an additional coating of enamel when specified.

Waxed			Not Waxed		
Code No.	Color	No. Ft. Per Lb.	Code No.	Color	No. Ft. Per Lb.
F-442	Red	100	F-441	Red	100
F-444	Black	100	F-443	Black	100

Kellogg Flameproof Jumper Wire

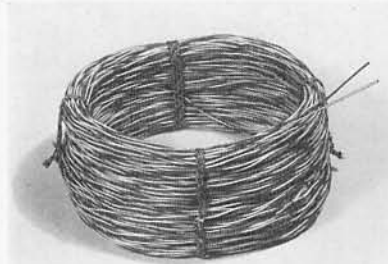

This special Kellogg wire was designed to meet a demand for a jumper wire of small diameter with high insulation resistance and flame resisting qualities. In addition to these advantages the wire comes in bright, attractive colors, has a low mutual

capacity rating and excellent moisture proof qualities. Its construction also permits the use of highest quality materials at reasonably low prices.

This jumper wire is made of 22 B.&S. gauge tinned or tinned-enameled copper wire. Two wrappings of cellulose acetate yarn are applied to it in reverse directions and then an outer covering of cotton. These wrappings are then impregnated with a special Kellogg cellulose acetate lacquer, giving the wire a hard, smooth, dust-free finish. This compound resists flame, moisture and corrosion.

Kellogg Flameproof Jumper Wire is shipped in 500 and 1000 foot coils of one continuous length. This flameproof wire has a lay of approximately two inches, or six twists per foot.

Code No.	Type Wire	Number of Strands	Colors	Weight Per 1000 Feet
3002	Tinned	Two	Red, White	10 lbs.
3002-E	Tinned, Enameled	Two	Red, White	10 lbs.
3003	Tinned	Three	Red, White, Blue	15 lbs.
3003-E	Tinned, Enameled	Three	Red, White, Blue	15 lbs.

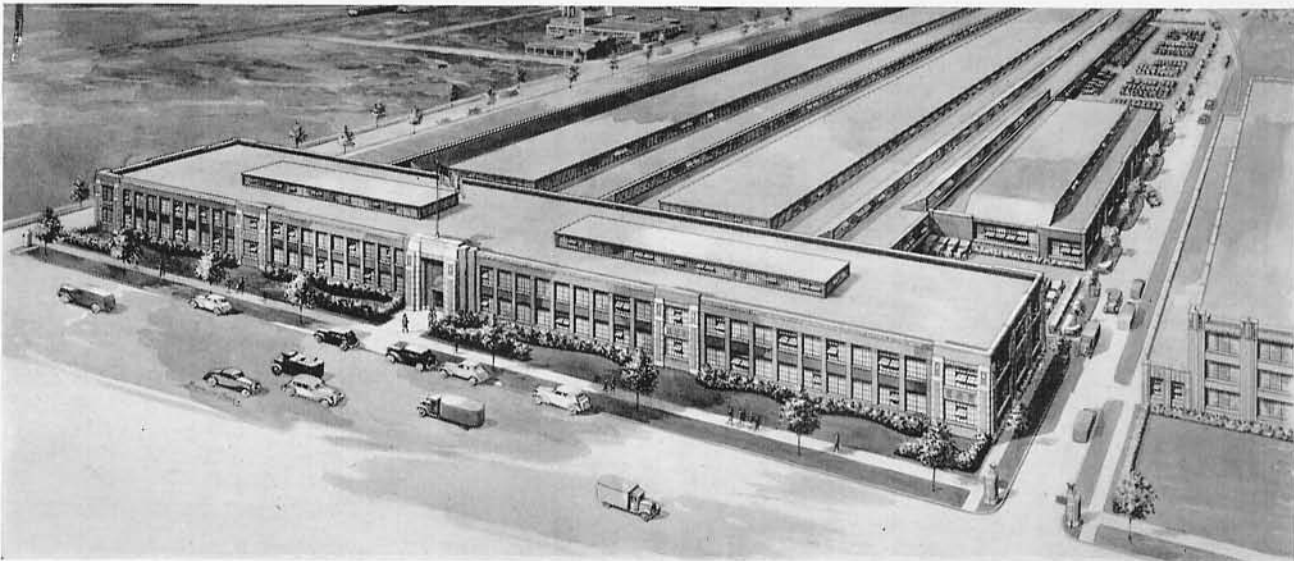

Factory and General Offices of Kellogg Switchboard and Supply Company, Chicago, Illinois, U. S. A.

Cord Section

KELLOGG KOILED KORDS

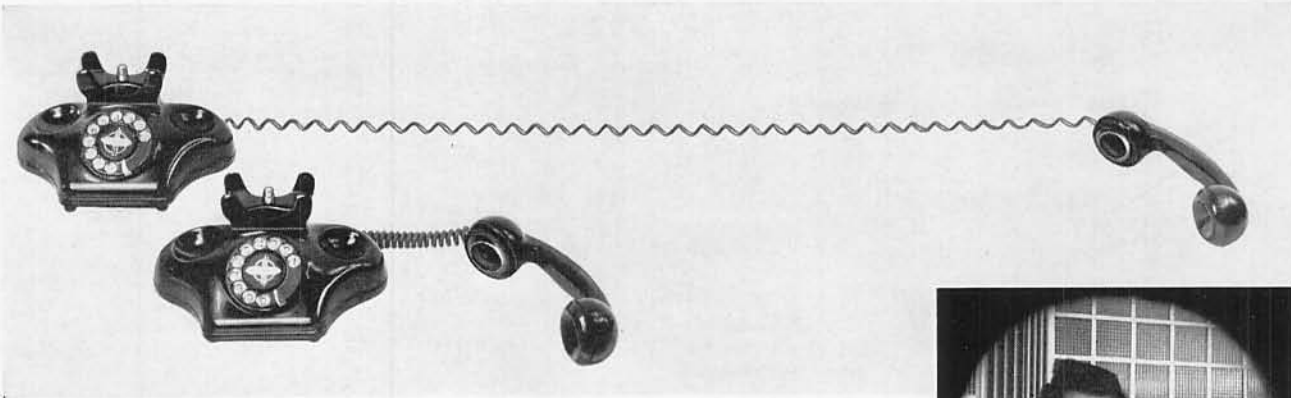

Here's the newest idea in retractable instrument cords that combines ALL the things you and your subscribers want. They work as smooth as a coil spring and stretch out with the greatest ease from 6 to 7 times their normal 9-inch contracted length. Yet, they are always ready to retract again into a short, neat, out-of-the-way spiral. These cords save telephone breakage because they are not apt to tangle with other objects or catch under desk or table corners.

The expanding and contracting action of Kellogg Koiled Kords is entirely secured by molding the outer rubber covering into this permanent coiled shape. This patented construction makes it the finest, longest-wearing cord of this type because it does not depend upon any other mechanical means such as metal springs, formed wires, braided conductors, sewed-in rubber bands, etc., to provide the retractable action. Thus, there is no undue wearing of the insulation. The insulated tinsel conductors are molded through the center of the rubber covering where they are free from sharp bends and folds, assuring long, satisfactory cord life. Long life of the rubber sheath is assured by molding the cord in spiral form so that it is not under tension when at rest.

Kellogg Koiled Kords are substantially kink-proof and soil-proof. The coils are only $\frac{3}{8}$ inch in diameter. In ordering specify catalog numbers and make of phone. Net weight, each is 4 ounces.

Four

Conductor Cords

Cat. No. KH-4A, used for Kellogg handsets. Tracer colors are red, green, orange and black. Trim lengths: handset end — black, 4 in., other three, 1 in.; instrument end — black, and orange, 10 in., red and green, $6\frac{1}{2}$ in.



Three Conductor Cords

Cat. No.	Used for Handset	Tracer Colors
KH-3A	Kellogg	Red, Yellow, Green
WH-3A	Western Elec., North Elec.	Red, White, Black
SH-3A	Stromberg-Carlson	Green, Red, Orange
AH-3A	Automatic Electric	Brown, Red, Orange
LH-3A	Leich Electric	Orange, Red, Green

Two Conductor Cords

Cat. No. LR-2A, used for receivers. Extended length is 36 in., condensed length, 6 in. Trim length: 4 in., spade tips; 3 in., spike tips.

INDEX

	Page
Breastplate Transmitter Cords	12
Cable	
Switchboard Cable	17
Power Cable	18
Cable Wire	18
Cord Drawings	6 to 15
Cord Hooks	16
Cord Tips	16
Cord Weights	16
Cords	
Breastplate Transmitter Cords	12
Desk Stand Cords	8, 9, 10
Desk Stand Transmitter Cords	10
Handset Cords	6, 7, 8
Kellogg Koiled Kords	20
Operators Cords	12, 13
Receiver Cords	11
Switchboard Cords	14, 15
Switchboard Patching Cords	15
Switchboard Suspended Type Cords	10
Cords Listed by Types	4
Desk Stand Cords	8, 9, 10
Desk Stand Transmitter Cords	10
Drawings, Cord	6 to 15
Fasteners, Cord	16
Flameproof Jumper Wire	19
Flexible, Insulated Stranded Wire	18
Generator Wire	19
Handset Cords	6, 7, 8
Jumper Wire, Flameproof	19
Kellogg Cords Listed by Types	4
Kellogg Equivalents of Other Cords	5
Kellogg Koiled Kords	20
Lacing Twine	17
Operators Cords	12, 13
Patching Cords, Switchboard	15
Plug Cushions, Rubber	16
Power Cable	18
Receiver Cords	11
Specifications and Cord Drawings	6 to 15
Stranded Wire, Insulated	18
Suspended Type Switchboard Cords	10
Switchboard Cable	17
Switchboard Cords	14, 15
Switchboard Patching Cords	15
Switchboard Wire	18
Telephone Cable Wire	18
Tips, Cord	16
Tools	15
Transmitter Cords, Breastplate	12
Transmitter Cords, Desk Stand	10
Twine, Lacing	17
Weights, Cord	16
Wire	
Flameproof Jumper Wire	19
Flexible, Insulated Stranded Wire	18
Generator Wire	18
Switchboard Wire	18
Telephone Cable Wire	18