



# REPEATING COILS AND PHANTOM CIRCUITS BULLETIN NO. 98 AUGUST 1917

A tutorial on repeat coils and phantom circuits.

Printed in booklet form, 7.5 X 10 inches, gutter bound, 8 pages on 20 pound coated stock using the letterpress method. This piece was two hole punched on the left side. Part of a catalog set containing 13 booklets and several single sheet brochures ranging in dates from 1914 to 1918 and bound under a separate hard cover using Chicago screws.

Scanned from an original document furnished by Wayne Merit  
JKL Museum of Telephony

[www.jklmuseum.com](http://www.jklmuseum.com)

Adobe Document Scanned and Produced by Mike Neale, Member of  
Antique Telephone Collectors Association US  
Telephone Collectors International US

[www.kelloggtelephone.com](http://www.kelloggtelephone.com)

[www.redbartelephone.com](http://www.redbartelephone.com)

[www.selectophone.com](http://www.selectophone.com)

Adobe Document Contents Copyright 2008, Mike Neale, Midland, Texas, USA  
Optimized for viewing with Adobe Reader 7.0 or better and web loading.



[www.atcaonline.com](http://www.atcaonline.com)



[www.telephonecollectors.org](http://www.telephonecollectors.org)



BULLETIN No. 98

(Copyright by  
Kellogg S. & S. Co.)

AUGUST, 1917

# Repeating Coils and Phantom Circuits

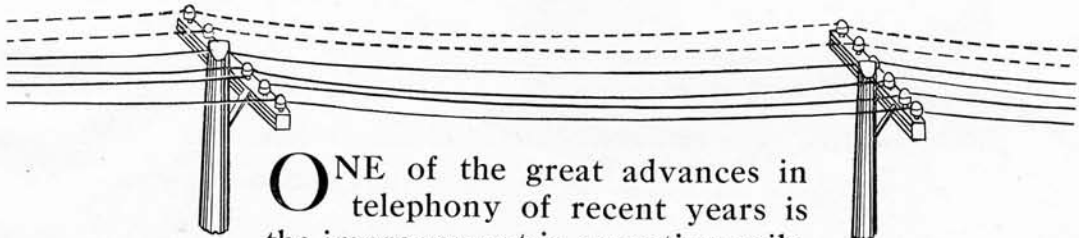

ONE of the great advances in telephony of recent years is the improvement in repeating coils.

Kellogg coils are properly designed and built, they have increased efficiency of transmission and effected material savings in construction. *Use is the test.*



THE PHANTOM COIL

“In its certainty of accomplishment, its return of real profit, as well as the wonder of its mystery, the *phantom coil* portrays the romance of telephony. Its story, perhaps, knows no equal in the realm of the electric current.”

---

**Kellogg Switchboard & Supply Company**

Main Offices—Chicago, Illinois

Kansas City, Missouri

San Francisco, California

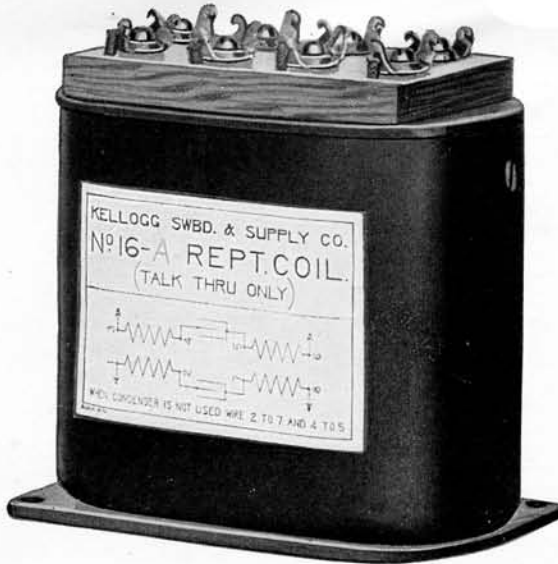

Fig. No. 9801—No. 16-A Repeating Coil

The conditions under which repeating coils are used vary greatly according to local requirements.

The Kellogg Switchboard & Supply Company has recently developed two new repeating coils which meet all the requirements of modern telephone practice.

The No. 16-A repeating coil shown in Figure No. 9801 is the most efficient on the market for talking purposes. The mounting centers and dimensions of this coil are given in Figure No. 9802.

No. 17-A coil shown in Figure No. 9803 is the ring-through type and is as efficient for talking as the No. 16-A type. Figure No. 9804 shows the dimensions and mounting centers of the No. 17-A type coil.

### CONNECTIONS OF REPEATING COILS

No. 16-A repeating coil has four windings. The resistance between terminals 1 and 2 is 20 ohms; 3 and 4, 16 ohms; 5 and 6, 20 ohms, and 7 and 8, 16 ohms.

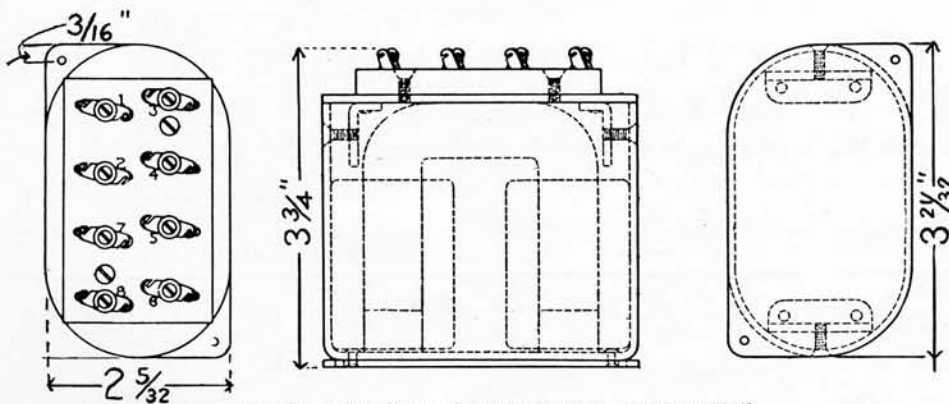

Fig. No. 9802—Dimensions of No. 16-A Repeating Coil

No. 17-A repeating coil has four parallel windings, 26 ohms to each winding.

Where it is necessary to use repeating coils in cord circuits, some thought should be given to the class of service in which they are used, as to whether the coil should be of the ring-through or non-ring-through type.

In magneto switchboards where two clearing-out drops are used, and condensers inserted in the tip and sleeve of the cord circuit to prevent ringing-through and hang-up trouble, the repeating coils, used to connect grounded lines to metallic lines, and local lines to toll lines, should be constructed so as to prevent ringing current from passing inductively from one winding to the other, while the high frequency voice currents pass with only a slight loss.

In single supervision cord circuits for magneto and toll connections, the No. 17-A coil in Figure No. 9803 should be connected as shown in Figure No. 9807, as it is necessary to ring or signal through



Fig. No. 9803—No. 17-A Repeating Coil

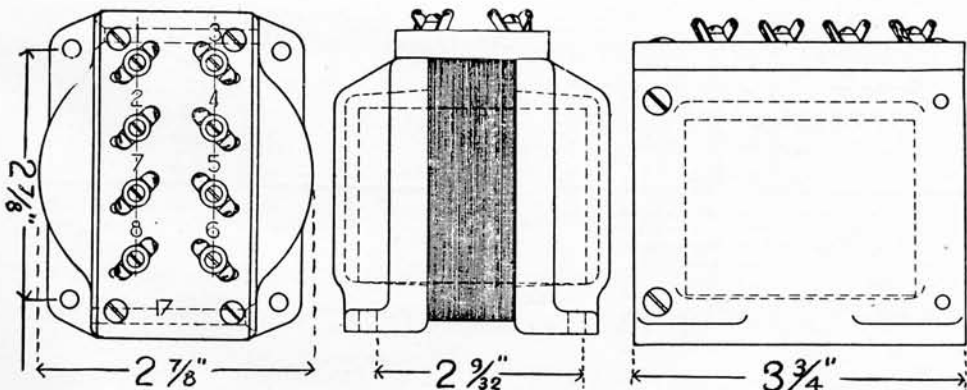

Fig. No. 9804—Dimensions of No. 17-A Repeating Coil

inductively from the calling side of the cord circuit to the answering side, in order to operate the ring-off drop.

When local to toll cord circuits are arranged with keys to cut off battery for use on toll to toll connections, the ring must be repeated in order to operate the ring-off drop and a No. 17-A coil should be used as shown in Figure No. 9805.

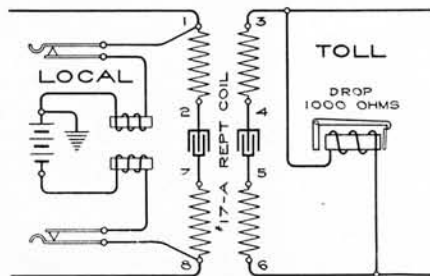

Fig. No. 9805—Connections of No. 17-A Repeating Coil, Common Battery to Toll with Key to Cut Off Battery for Use on Toll to Toll

Where repeating coils are used to connect common battery lines to common battery lines, they should be of the No. 16-A type, and connected as shown in Figure No. 9808.

To connect common battery lines to toll or magneto lines, a No. 16-A type repeating coil should be used, and connected as shown in Figure No. 9809.

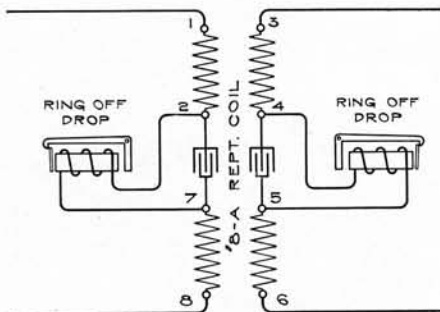

Fig. No. 9806—Connections of No. 8-A Repeating Coil, Magneto to Magneto, Non-hang-up Non-ring-through, for Local Connections Only

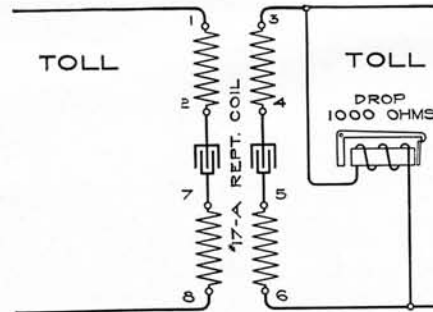

Fig. No. 9807—Connections of No. 17-A Repeating Coil, Toll to Toll

## PHANTOM CIRCUITS

Where two well balanced metallic telephone circuits exist, Kellogg No. 17-A repeating coils make it possible to obtain a third

circuit without stringing additional wires, which, under good conditions, is more efficient for transmission than either of the original circuits. The two original circuits are called physical or real circuits, and the third circuit, a phantom or derived circuit.

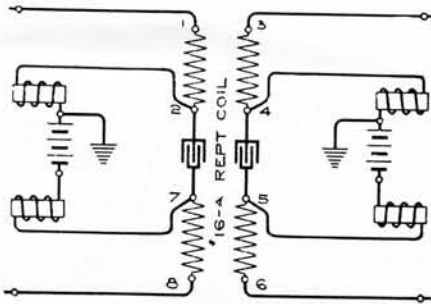

Fig. No. 9808—Connections of No. 16-A Repeating Coil, Common Battery to Common Battery

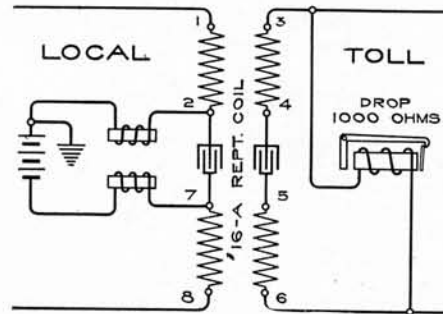

Fig. No. 9809—Connections of No. 16-A Repeating Coil, Common Battery to Toll

The introduction of repeating or retardation coils makes it possible to use the two wires of the first physical circuit for one wire or leg of the phantom circuit, and the two wires of the second physical circuit for the second wire or leg, thus obtaining a third circuit over which conversation can be carried without interfering with the conversation on the two original circuits.

## OBTAINING PHANTOM CIRCUITS

To introduce a phantom circuit on two metallic physical circuits, repeating coils are connected, as shown in Figure No. 9811. Four No. 17-A repeating coils are connected, one on each end of each line between the switchboard and line side. The repeating coils are perfectly balanced and one side or leg of the phantom is connected on the center taps Nos. 4 and 5, as this point is potentially the same as the line wires, and from No. 1 exchange to No. 2 exchange, both wires are used as one side of the phantom circuit. Leg No. 1 and Leg No. 2 are carried to the switchboard as a regular circuit.

When it is desired to obtain a phantom circuit on rural lines, the repeating and retardation coil scheme should be used as shown in Figure No. 9812. The use of No. 40-A retardation coils makes it possible to phantom rural lines having stations connected between the points where the phantom is to be taken off.

The dimensions and structure of the No. 40-A retardation coil are similar to the No. 17-A repeating coil.

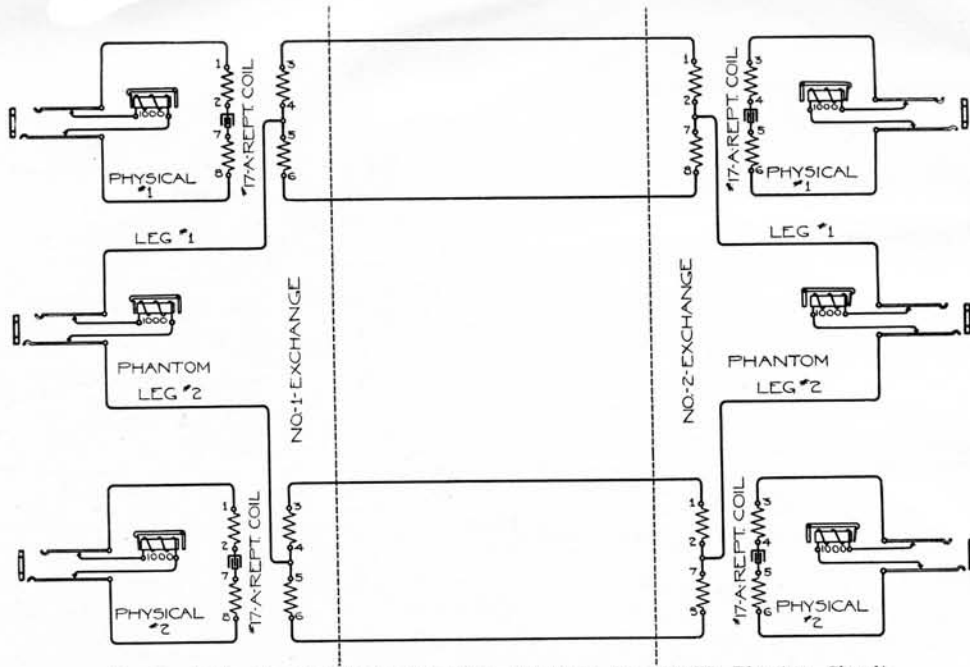

Fig. No. 9811—No. 17-A Repeating Coils, Connected for Metallic Phantom Circuit

## LINE CONDITIONS

The two sides of the phantom circuit must be well balanced in regard to the resistance of each wire, and must be free from grounds or foreign contacts. For this reason, it is not practical to phantom two dissimilar circuits as an iron with a copper, or two coppers of different gauges, unless the circuits are transposed so that each side of the phantom circuit will consist of practically equal parts of conductors of the different gauges.

The location of the circuits on the cross-arms should be arranged so that transpositions can be easily made. Pins 1 and 2; 3 and 4; 7 and 8, and 9 and 10, are more desirable for phantoms on this account. Pins 5 and 6 are very seldom used, as their being nearer the pole usually makes them of a lower insulation and the spacing of the pins tends to unbalance the phantom.

## TRANSPOSITIONS

If the toll lines extend considerable distance through cable, some cross-talk may be experienced, and where considerable phantoming exists a duplex cable transposed for phantoms should be used.

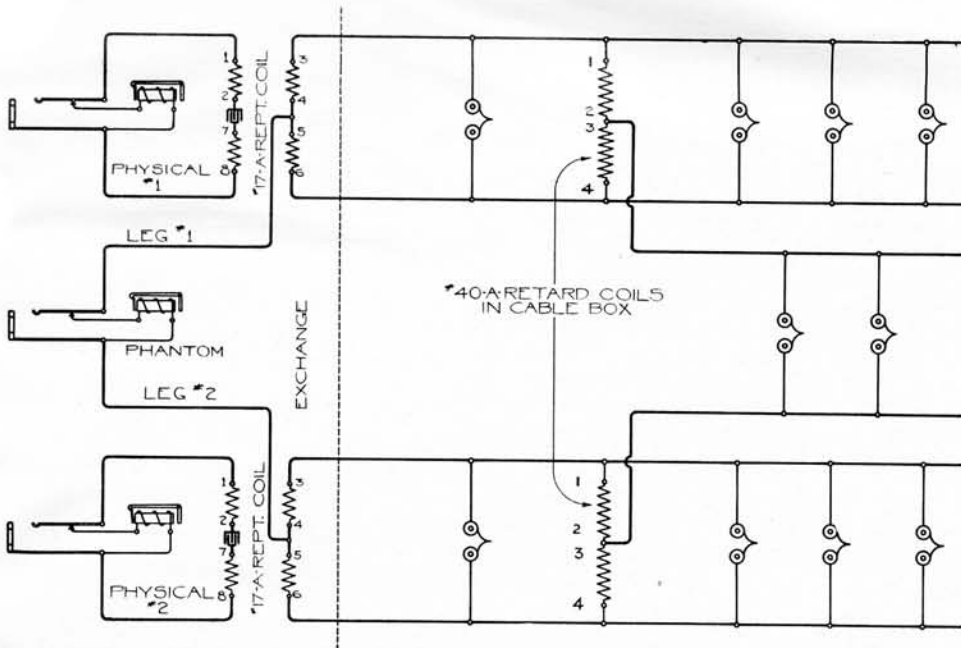

Fig. No. 9812—Connections for Metallic Phantom Circuits on Rural Lines, Using No. 17-A Repeating Coils at Exchange and No. 40-A Retardation Coils on Line

Where there is no exposure of the open line wires to foreign disturbances, phantoms will sometimes work successfully without being transposed, but if there is more than one phantom circuit the phantom should be transposed according to the scheme shown in Figure No. 9813.

Special phantom transposition brackets, as shown in Figure No. 9814, give the best results as they facilitate making the transpositions without the necessity of bridling.

There are four different types of phantom transpositions, as shown in Figure No. 9815.

Type No. 1.—Where both physical circuits are transposed.

Type No. 2.—Where only one physical circuit is transposed, and that on the left side.

Type No. 3.—Where only one physical circuit is transposed, and that on the right side.

Type No. 4.—Where neither physical circuit is transposed.

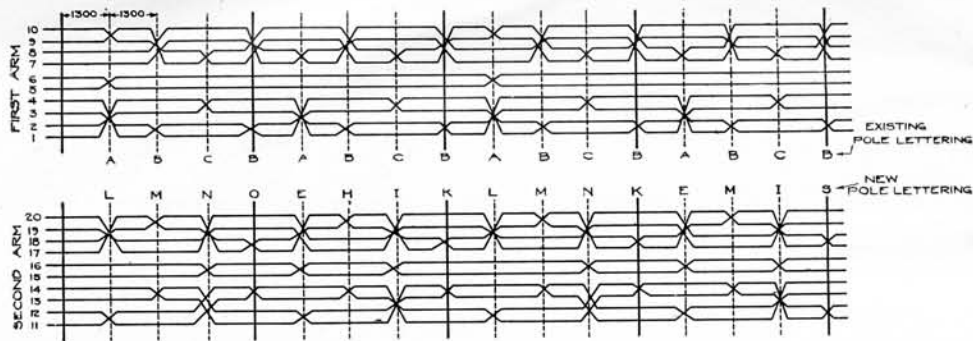

Fig. No. 9813—Showing Line Arranged for Four Phantom Circuit Transpositions

The method of running the wires and tying to the transposition bracket is shown in Fig. 9816.

Where a number of phantoms are used, the coils should be wired to jacks or plugs on a test panel so as to allow the phantom to be taken down when trouble exists. The arrangement of wiring phantoms into test boards is to wire the four line terminals of the repeating coils between the line jacks and switchboard jacks, as shown in Figure No. 9817.

The phantom taps from the coils should be brought to at least a pair of jacks so that they may be plugged to any desirable number on the switchboard.

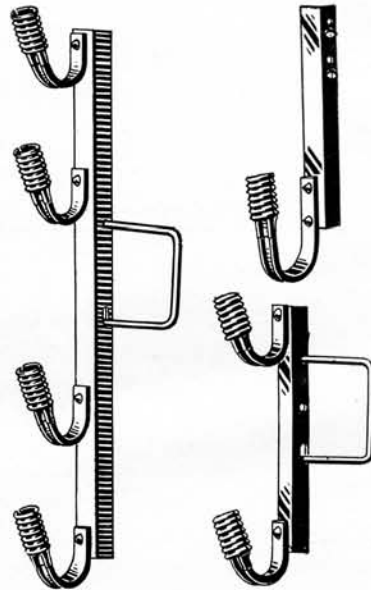

Fig. No. 9814—Phantom Transposition Brackets

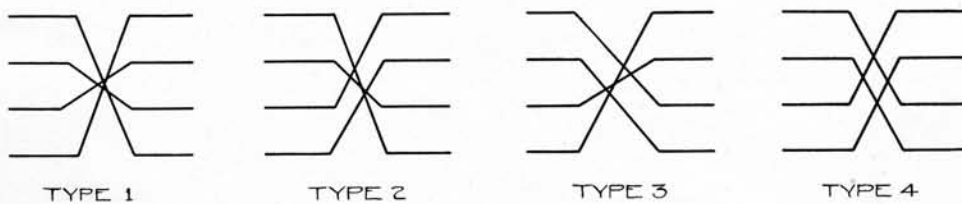

Fig. No. 9815—Types of Phantom Transpositions

The various types of transposition shown in Figure No. 9815 are made in the same manner as that of type No. 4 (Fig. 9815) which is shown in Figure No. 9816 except that the regular trans-

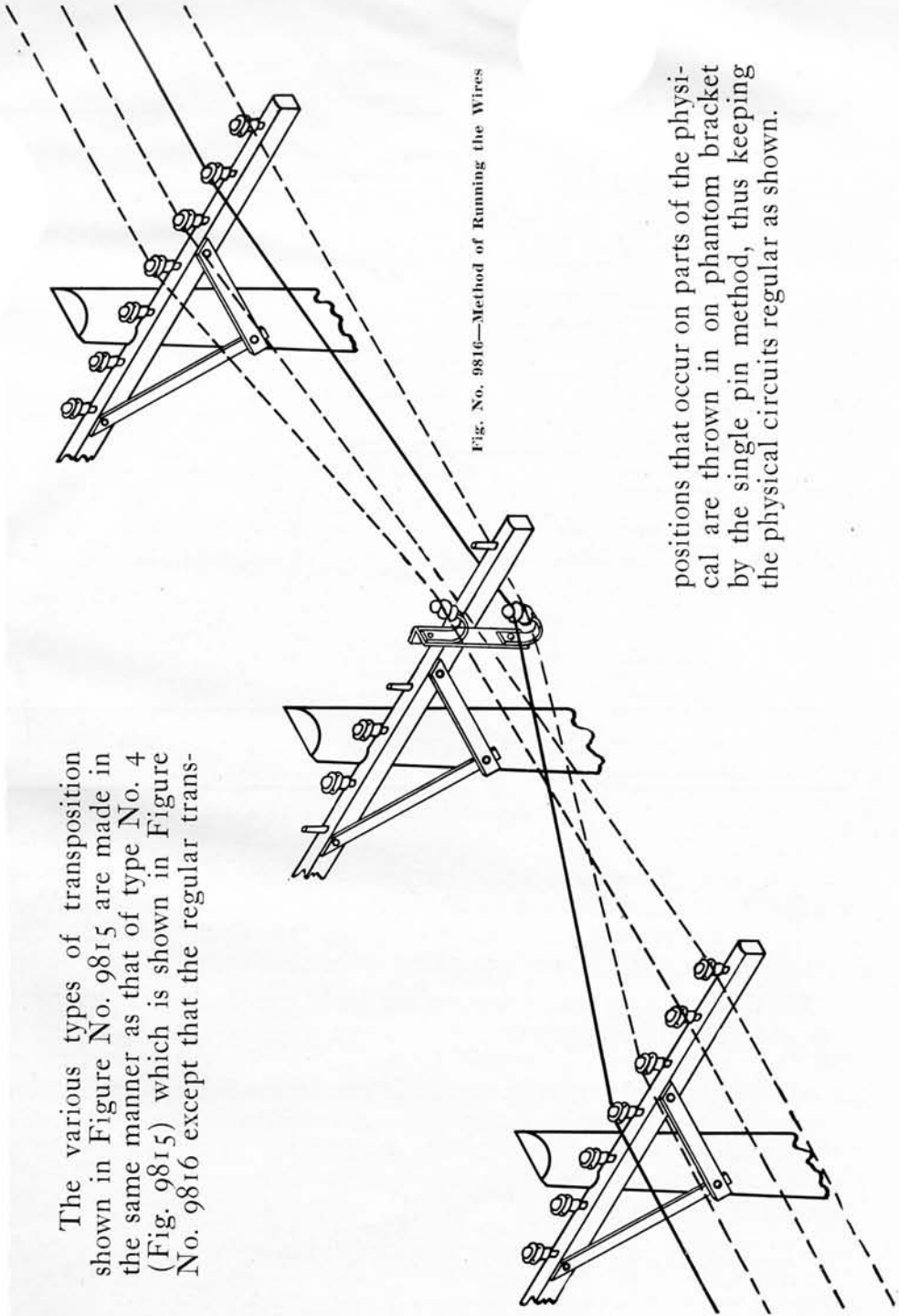

Fig. No. 9816—Method of Running the Wires

positions that occur on parts of the physical are thrown in on phantom bracket by the single pin method, thus keeping the physical circuits regular as shown.

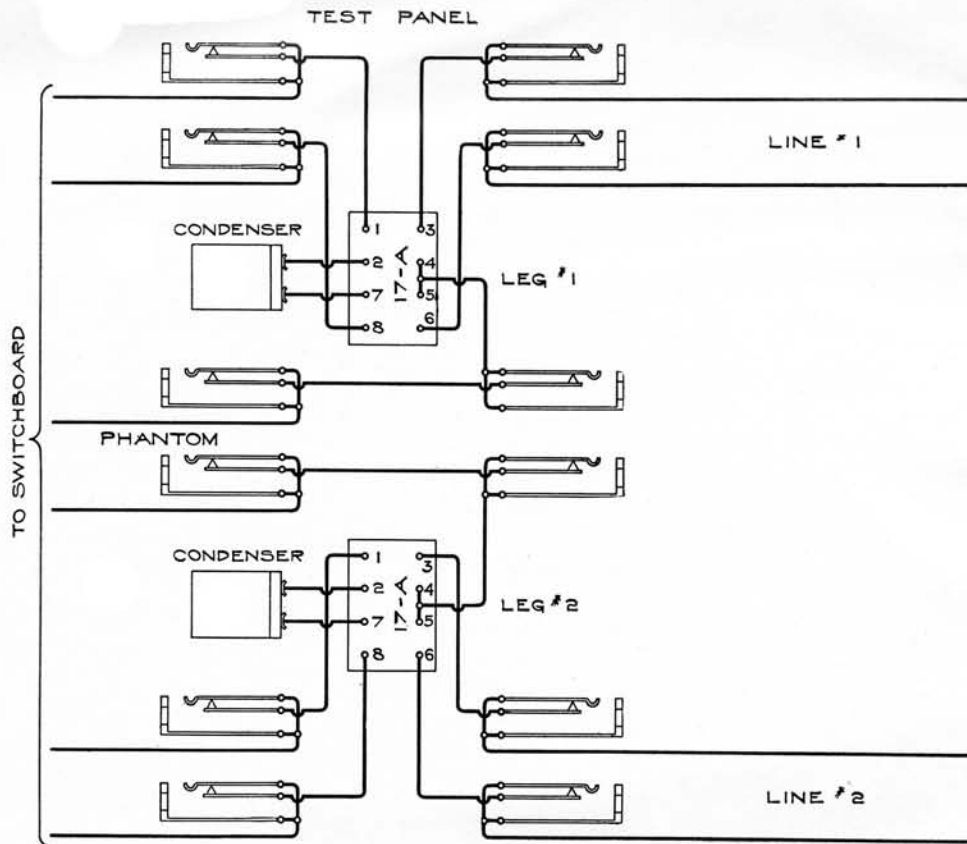

Fig. No. 9817—Method of Wiring Coils to Test Panel

When the phantom is to be permanent, it is preferable to wire the taps to jacks the same as in ordinary toll lines which will permit tests to be made both in and out on the phantom circuit. Test boards for this purpose are described in our bulletin No. 49.

Where repeating and retardation coils are used for phantom work, they should be protected from lightning and foreign currents. The office end will be protected if repeating coils are connected on the inside of the present protection. When repeating and retardation coils are mounted in cable boxes on poles to obtain phantom circuits, a dust and weather-proof arrester having an exceptionally large discharge area should be used. The method of connecting protection is shown in Figure No. 9818.

Where the traffic on two physical circuits is heavy and not enough to warrant stringing new wires, the introduction of a phantom circuit is always profitable, as the increased facilities provided will bring

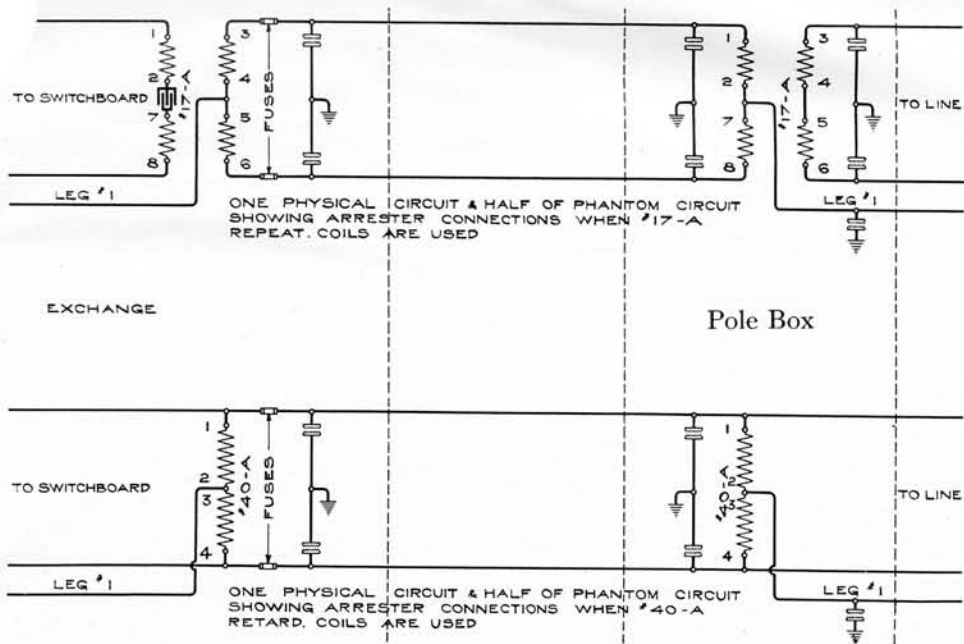

Fig. No. 9818—Connections to Lightning Arresters

the new business which always results from improved service, and more than justifies the expenditure.

Phantoms on farm lines will often allow the connecting of from eight to twelve new telephones, the revenue from which will more than pay for the phantom apparatus.

We especially recommend our repeating and retardation coils as the most efficient type which has ever been built by any company. They are especially designed for long distance work where high efficiency talk and ring-through coils are desired.

If special conditions are present, write us in detail and we will be glad to assist. Our experienced practical engineers are at your service.

It will be noticed that condensers are shown connected in the center of the repeating coil on the switchboard side. These condensers should be from 4 to 8 M.F. in capacity. If so desired the condensers can be omitted and these inner terminals strapped, though in some cases the condensers are advantageous in increasing ringing efficiency. The condenser also insures the operation of the clear out drop. When a cord circuit is connected to a phantom line, the condenser prevents the coil from causing hangups, as did the old 80 ohm series ringer.

PHANTOM COMBINATIONS

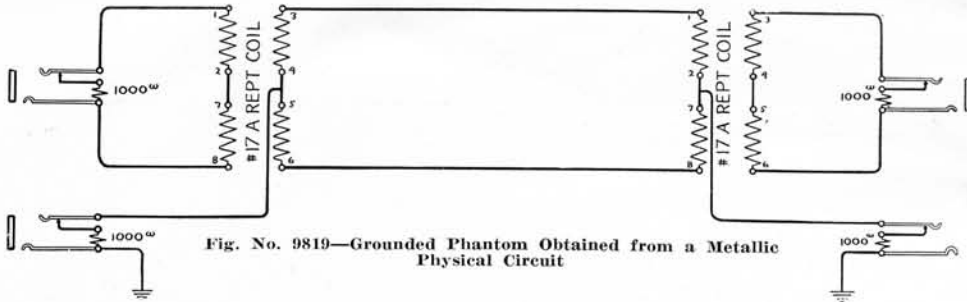

Fig. No. 9819—Grounded Phantom Obtained from a Metallic Physical Circuit

Figure No. 9819. Two wire line. One metallic circuit, one grounded phantom circuit. Can be used to advantage where the physical circuit does not parallel grounded telephone or high voltage transmission lines.

Various phantom combinations can be worked out, but usually the more complicated the phantom, or ghost, the more unreliable the operation.

Figure No. 9820. This shows a grounded phantom obtained from a metallic phantom derived from two metallic physical circuits.

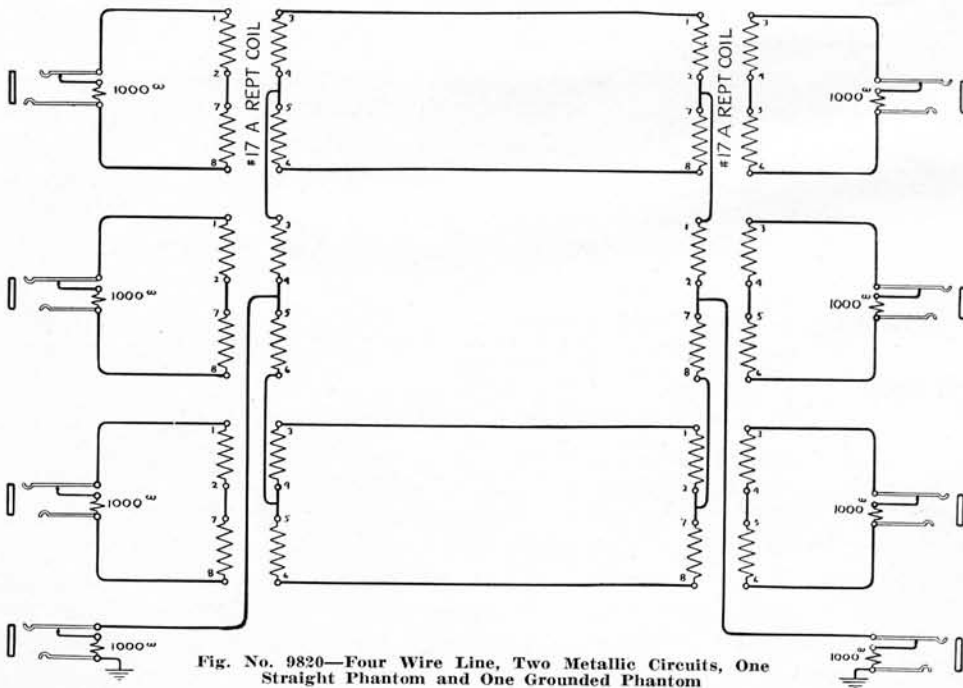

Fig. No. 9820—Four Wire Line, Two Metallic Circuits, One Straight Phantom and One Grounded Phantom

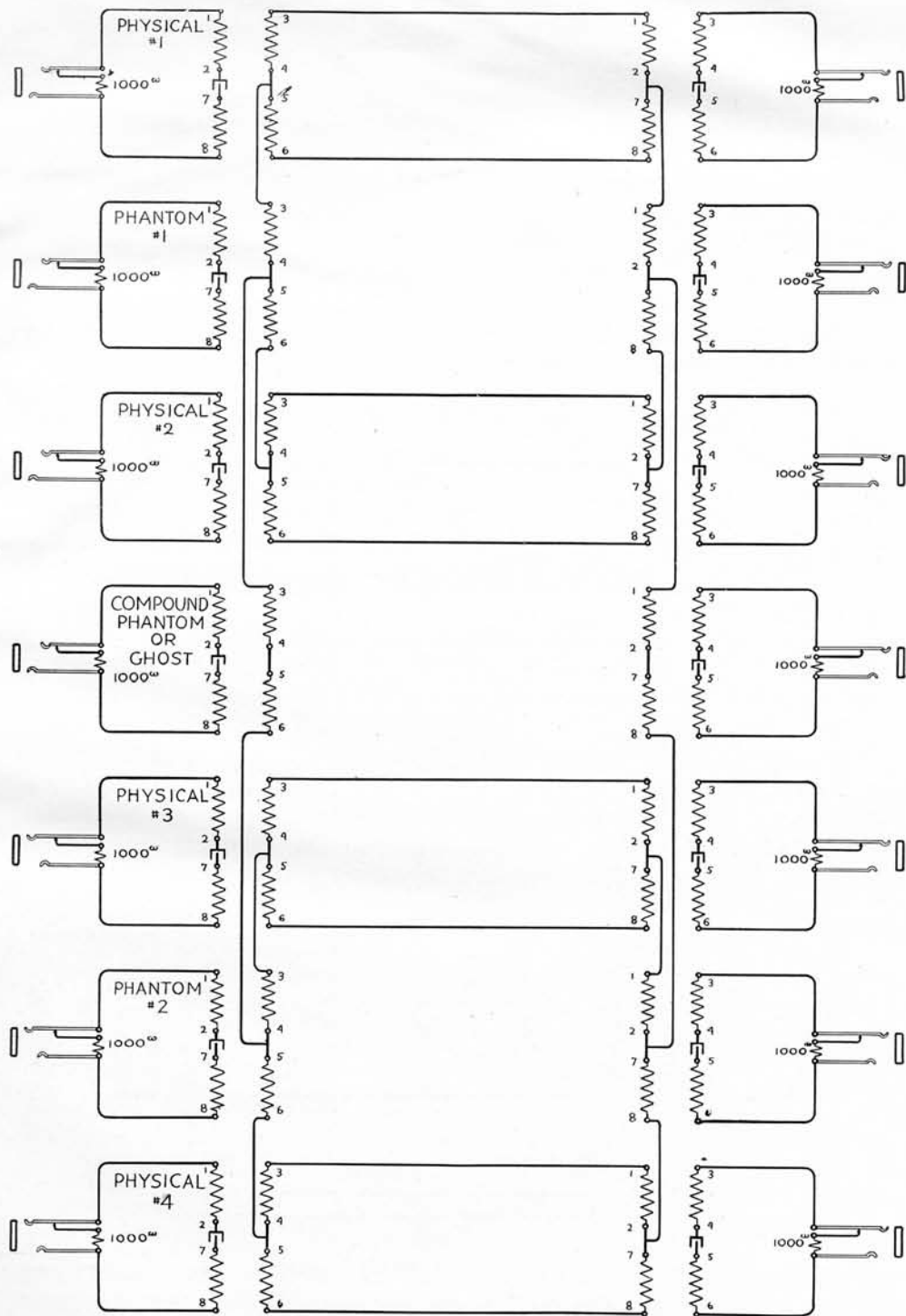

Fig. No. 9821—Eight Wire Line—Seven Metallic Circuits. Toll Line Arrangement

Figure No. 9821. This shows a compound phantom, or ghost, obtained from two metallic phantoms, each of which is derived from two physicals, making a total of seven circuits on four metallic circuits. All coils are 17-A repeating coils.

When different combinations of phantoms are worked out it must be borne in mind that the physical circuits should always be transposed according to an approved transposition scheme. The two physical circuits that form the phantom circuit should be transposed as shown in Figure No. 9816.

Always treat each two wires of the physical circuit as one wire when considering the phantom circuit.

### HIGH TENSION INTERFERENCE

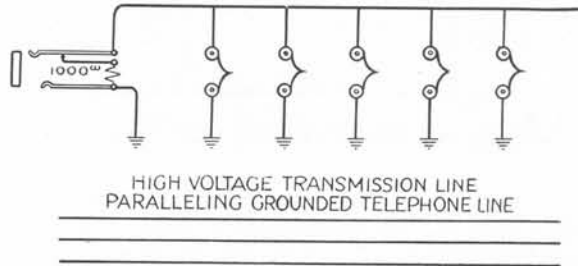

Fig. No. 9822

Where grounded lines are parallel to high tension lines, as shown in Figure No. 9822, it is possible to eliminate considerable induction by making the grounded line metallic, by stringing an additional wire over the distance with the high tension line parallel to the grounded line and connecting in a repeating coil as shown in Figure No. 9823.

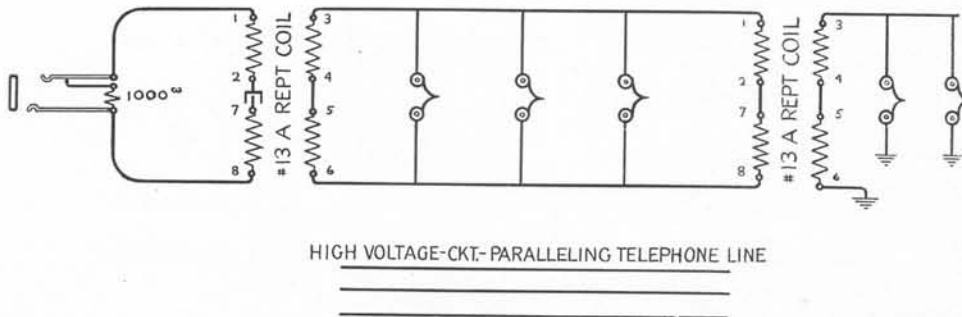

Fig. No. 9823

Where metallic lines parallel high tension lines disturbances can be reduced by drainage through repeating coils. Usually the inductive

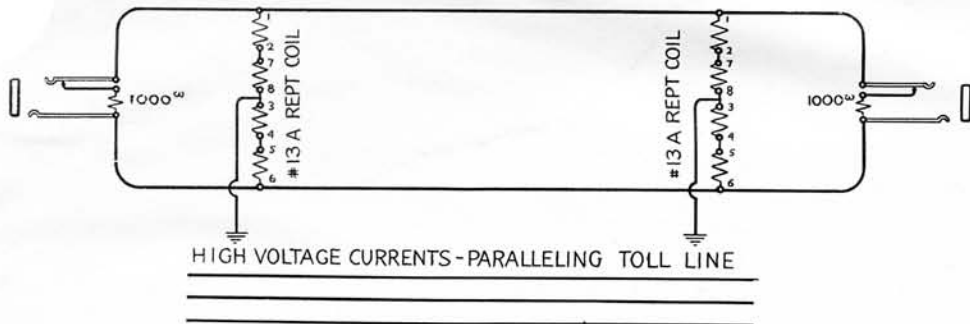

Fig. No. 9824

disturbances from high tension lines are in the form of a static earth seeking current. Repeating coils can be connected in the lines with the center terminals grounded, as shown in Figure No. 9823, to drain this static current over both sides of the line to the center of the repeating coil, thus neutralizing any disturbances on the drop side.

Figure No. 9824. Showing installation of No. 13-A repeating coil, or drainage coil, used to eliminate noise on metallic telephone line paralleled by high tension circuit.

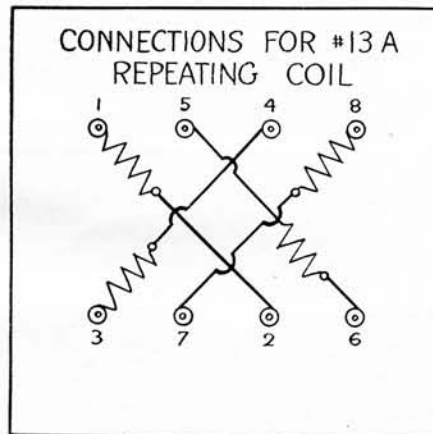

Fig. No. 9825

Eliminating inductive disturbances on lines paralleling high tension circuits presents a problem which sometimes requires a study of the local conditions. In a good many instances it requires special transposition in both the telephone circuit and transmission line in order to effect a state of equilibrium.

The proper transpositions will sometimes balance the disturbances and drainage will not be required.

When transpositions do not relieve the disturbances and drainage is resorted to, the coils must be protected from lightning and foreign currents with an approved type of arrester, preferably a self-cleaning arrester having exceptionally large discharge area, or a vacuum gap.

While it is possible to establish a state of equilibrium on one line, the same methods may possibly fail to produce the same results on another line. Even when a balance has been effected, the line will be subject to disturbances due to the variation in load on the high tension circuit, atmospheric conditions, and breaks in the line.

Any condition, in fact, which changes the potential of the high tension line in relation to grounds and leakages will affect the telephone line.

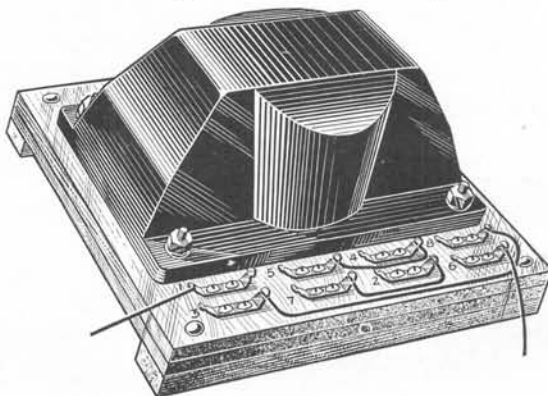

Fig. No. 9826—No. 13-A Drainage Coil, Showing Wiring

## Kellogg Switchboard & Supply Company

CHICAGO, ILLINOIS

Branch Offices: Kansas City, Mo., San Francisco, Cal.

Columbus, Ohio, 409 Huntington Bank Bldg.

DISTRIBUTING HOUSES: Canada, West Electric, Ltd., Regina, Sask., Can.; The McGraw Co., Sioux City, Iowa; The McGraw Co., Omaha, Neb.; Pacific States Electric Co., Los Angeles, Cal., Oakland, Cal., Portland, Ore., Seattle, Wash.; Northwestern Electric Equipment Co., St. Paul, Minn.; Tower-Binford Electric & Manufacturing Co., Richmond, Va.

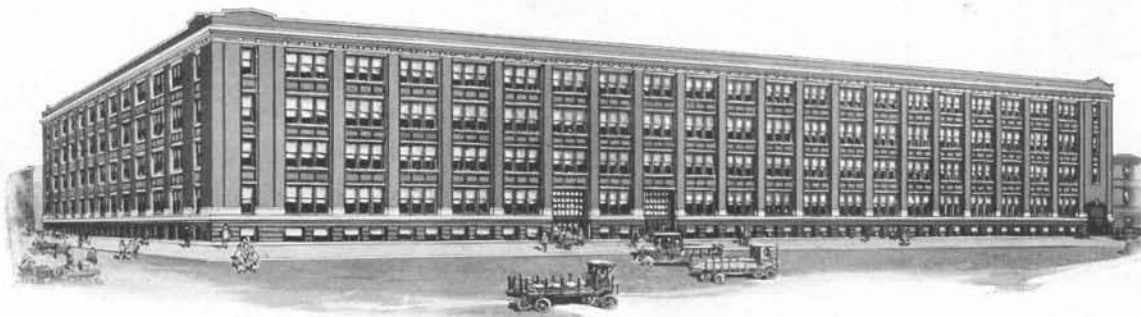

THE KELLOGG FACTORY—THE LARGEST OF ITS KIND IN THE WORLD